

BACK-TO-BACK MOUNTING KIT (1776250201)			
ITEM	PART NUMBER	DESCRIPTION	QUANTITY
A	1776005101	4000 BACK-TO-BACK HANGING BRACKET	2
B	61230705	8-32x.375 SCREW (BLACK)	8

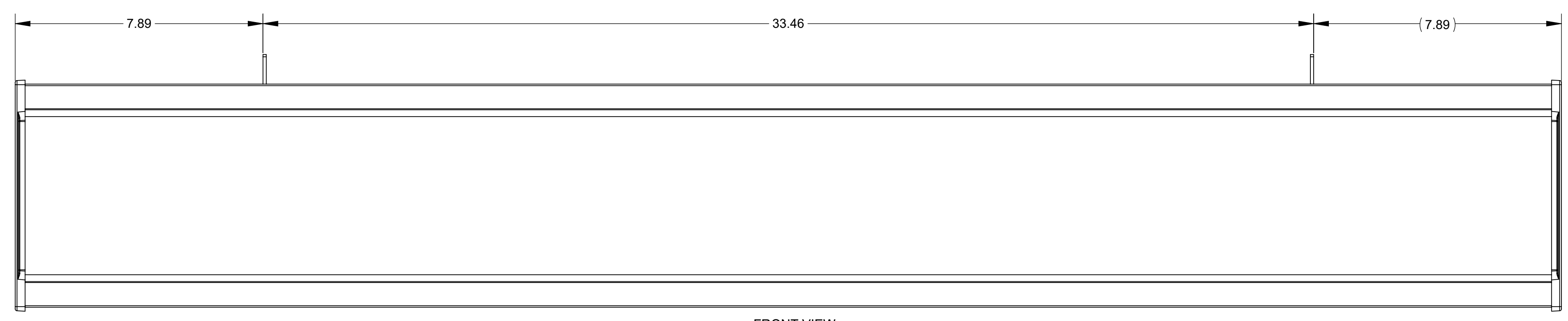

FRONT VIEW  
ALPHA 4160 MNS BACK-TO-BACK UNITS  
(APPROXIMATE HANGING WEIGHT = 28 LBS)

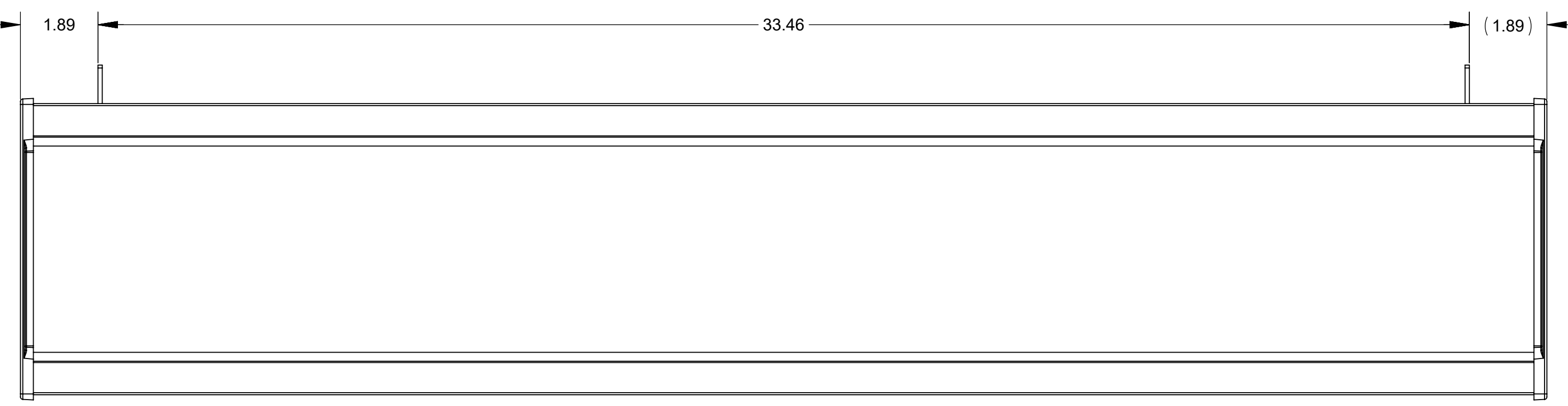

FRONT VIEW  
ALPHA 4120 MNS BACK-TO-BACK UNITS  
(APPROXIMATE HANGING WEIGHT = 22 LBS)

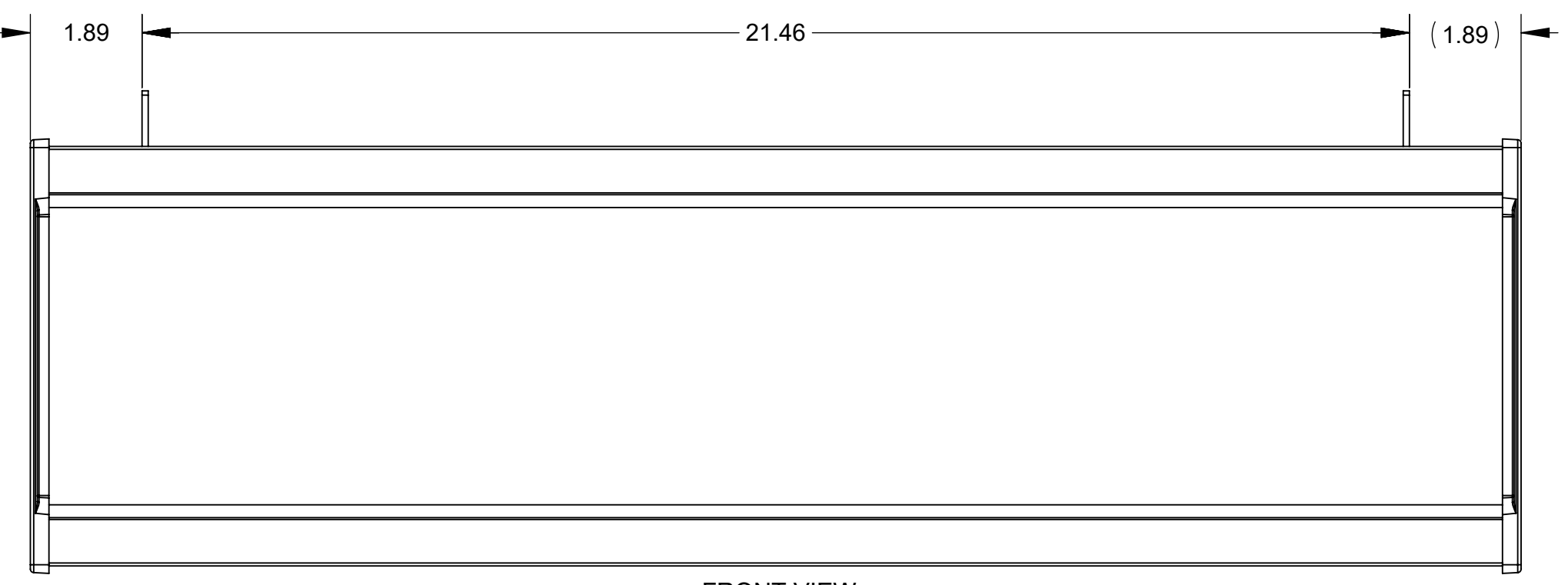

FRONT VIEW  
ALPHA 4080 MNS BACK-TO-BACK UNITS  
(APPROXIMATE HANGING WEIGHT = 16 LBS)

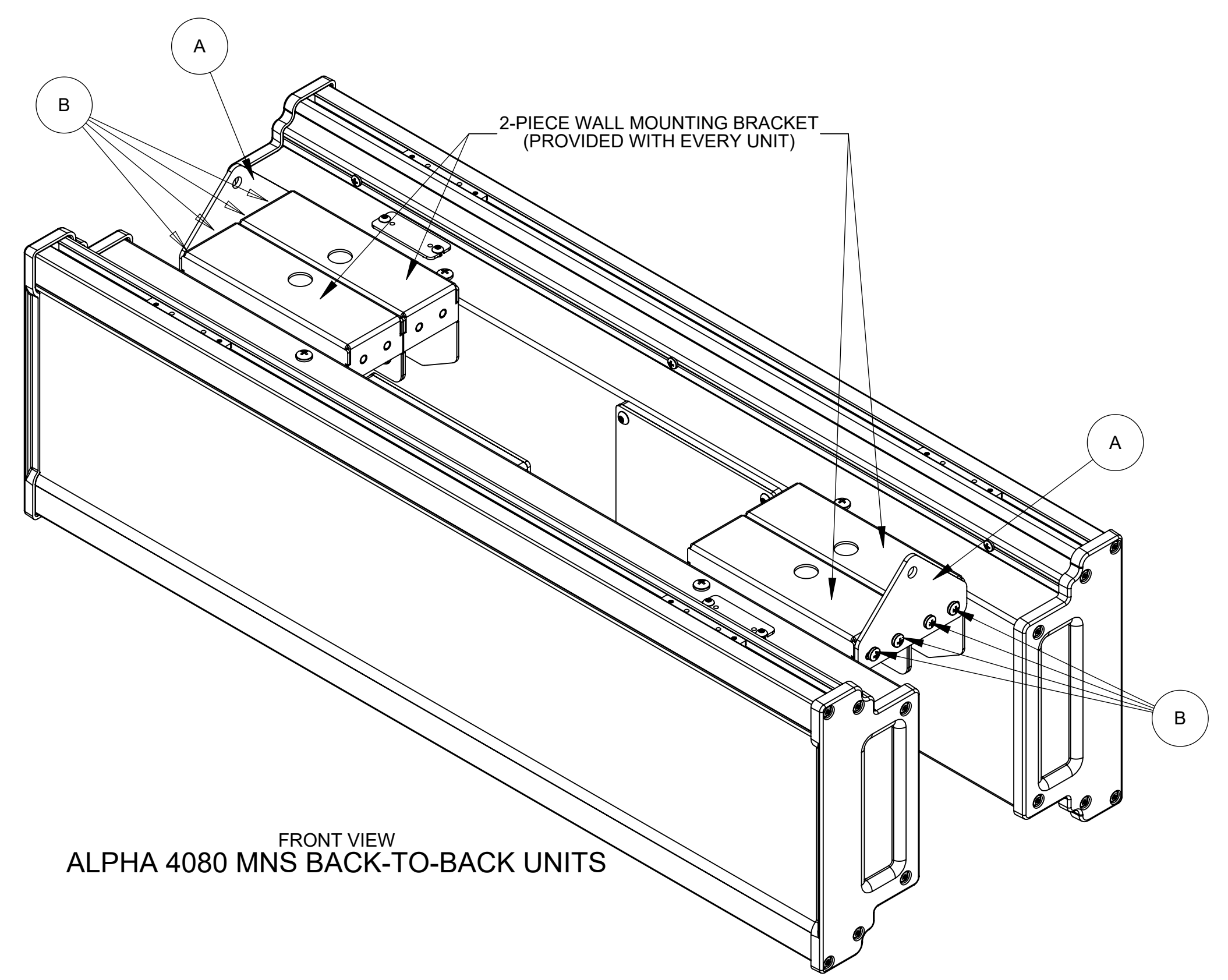
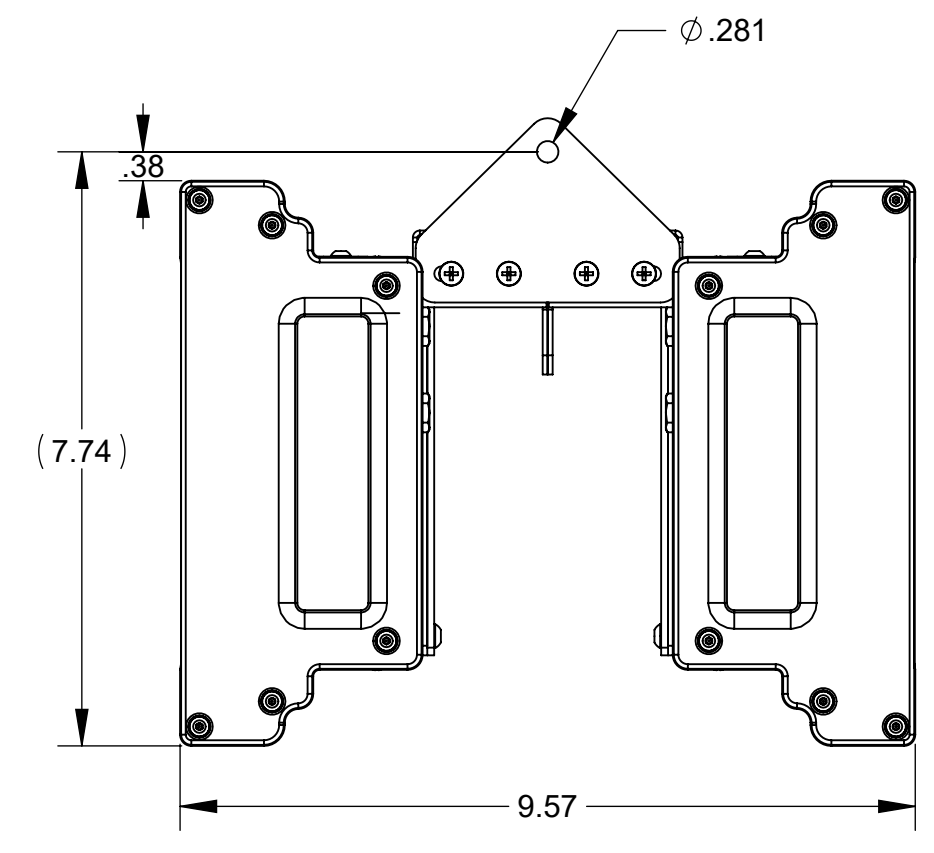

FRONT VIEW  
ALPHA 4080 MNS BACK-TO-BACK UNITS

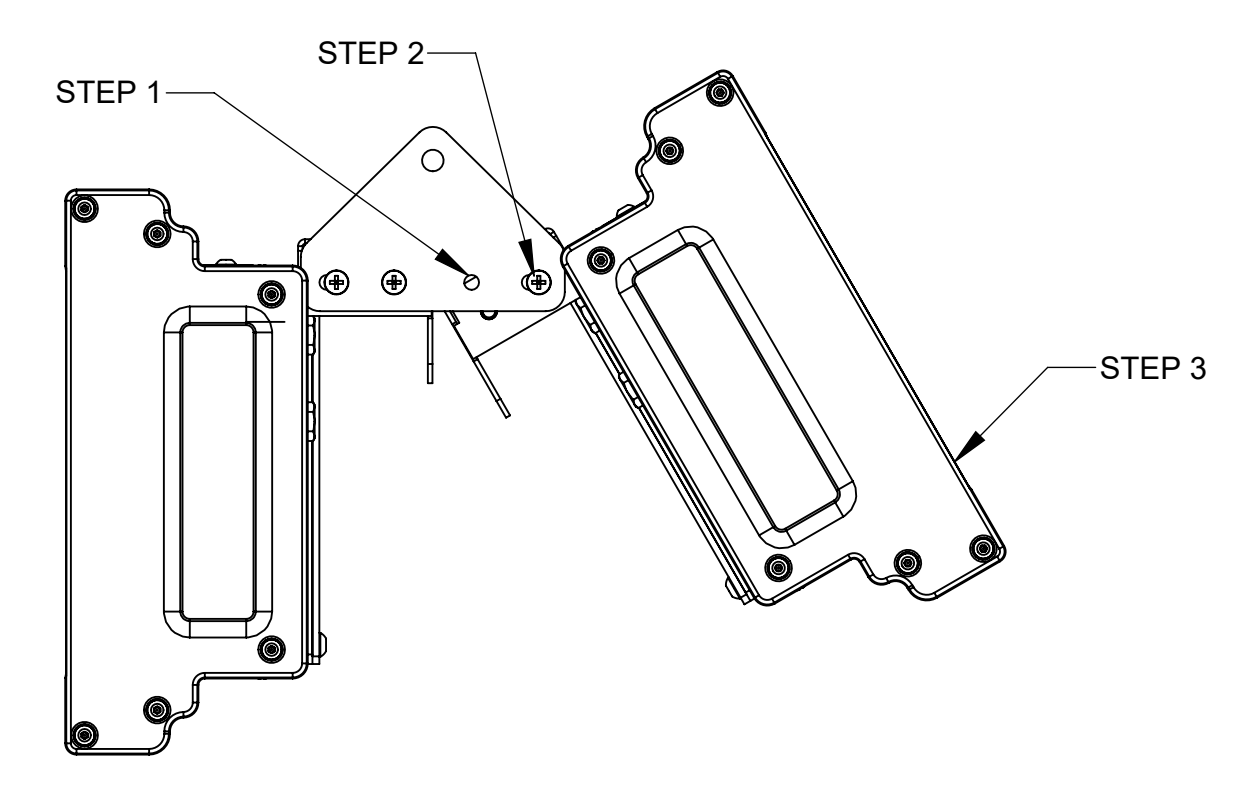

**TO ACCESS REAR PANEL IN BACK-TO-BACK CONFIGURATION:**  
 1) REMOVE THE FURTHERST 8-32 SCREW FROM THE UNIT (ON EACH SIDE)  
 2) LOOSEN THE NEAREST 8-32 SCREW FROM THE UNIT (ON EACH SIDE)  
 3) ROTATE THE UNIT UP WHICH WILL ALLOW THE REAR PANEL TO BE ACCESSED

DIMENSIONS ARE INCH AND TOLERANCES ARE AS FOLLOWS UNLESS OTHERWISE SPECIFIED: X ±0.1 XX ±0.02 XXX ±0.008 ANGLES ±1°				7840 North 88th Street Menasha, WI 53224 USA	
DESIGNED BY JDW	DATE 2/21/2018	TITLE SPEC, SALES DWG, 4000 MNS PoE, B2B CEIL MNT		DOCUMENT NO. 17765016DR	REVISION A
DRAWN BY JDW	DATE 2/21/2019	SCALE 2:5	STATUS Released	SHT 1 of 1	

REV.	DESCRIPTION	ECO.	BY	DATE
A	RELEASED FOR PRODUCTION	-	JDW	02/21/2019