

## Introduction

These instructions show how to mount, connect and change the serial address on Alpha series signs with NEMA Types 2, 4, 4X, and 12 enclosures.

- Type 2 enclosures are intended for indoor use primarily to provide a degree of protection against limited amounts of falling water and dirt.
- Type 4 enclosures are intended for indoor use primarily to provide a degree of protection against windblown dust and rain, splashing water, and hose-directed water.
- Type 4X enclosures are intended for indoor use primarily to provide a degree of protection against corrosion, windblown dust and rain, splashing water, and hose-directed water.
- Type 12 enclosures (in a gasketed, dust-free, sealed, spray-down resistant case) are intended for indoor use.

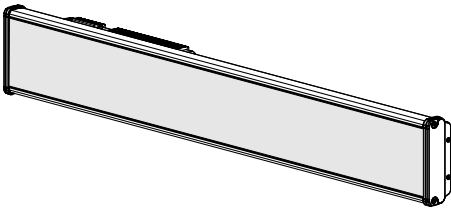

Alpha 4000 Series NEMA 12 model signs

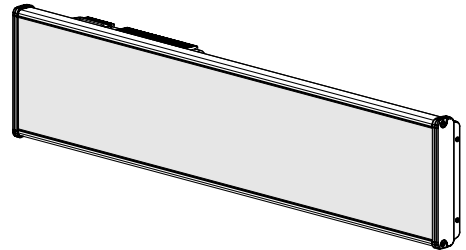

Alpha 7000 Series NEMA 4 and 4x model signs

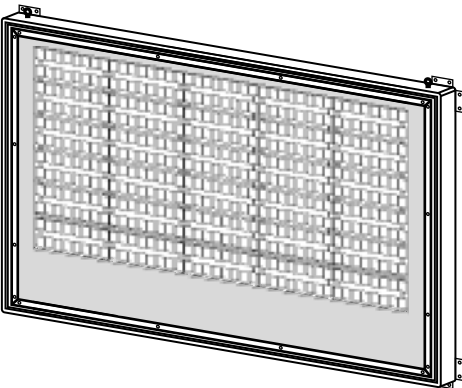

Alpha 3.2" Series NEMA 2 model signs

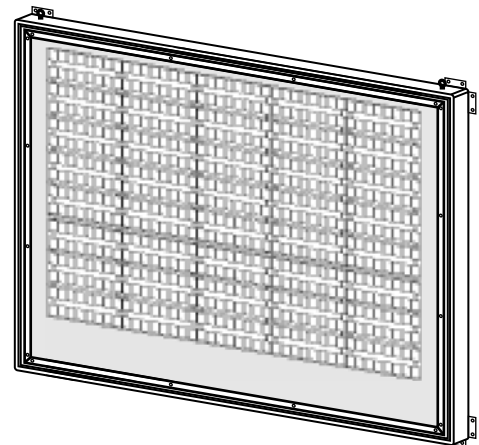

Alpha 2.1" Series NEMA 2 model signs

**NOTE:** Signs are not drawn to scale.

---

## Contents

---

<b>Introduction</b> . . . . .	<b>1</b>	<b>Installation</b> . . . . .	<b>5</b>
Changing the serial address . . . . .	2	Electrical installation guidelines . . . . .	5
Temperature protection in NEMA-rated enclosures . . . . .	3	Alpha 4000 series NEMA 12 models . . . . .	6
<b>Safety</b> . . . . .	<b>4</b>	Alpha 7000 series NEMA 4 and 4x models . . . . .	11
Equipment symbols . . . . .	4	2.1" NEMA 2 character matrix signs . . . . .	15
Warnings and Notices . . . . .	4	3.2" NEMA 2 character matrix signs . . . . .	20
Preventing electrostatic discharge damage . . . . .	4	<b>Checkout procedure</b> . . . . .	<b>24</b>
EMI compliance . . . . .	4		

---

## Changing the serial address

---

A serial address for an Alpha sign is a number from 0 to 255 (00 to FF hexadecimal.) It is used to identify the sign in a network of signs. All signs leave the factory with a default address of 0.

You can use DIP switches in most Alpha NEMA signs to set a permanent serial address:

- See “Changing the serial address on Alpha 7000 signs” on page 14.
- See “Changing the serial address on 2.1” NEMA 2 signs” on page 19.
- See “Changing the serial address on 3.2” NEMA 2 signs” on page 24.

To change a sign’s serial address on an Alpha 4000 or to override the serial address DIP switches on an Alpha 7000 series sign, follow these steps:



1. Point a hand-held remote control (shown at left) at the sign, and press PROGRAM.
2. Press **BACK** until **SET SERIAL ADDRESS** appears on the sign.
3. Press **ADV** and **SERIAL ADDRESS = 00** appears.
4. Type in the new serial address using the numbered keys on the remote control.
5. Press **RUN** twice to set the new serial address and return the sign to normal operation.

## Temperature protection in NEMA-rated enclosures

Alpha signs in NEMA-rated enclosures have automatic temperature controls that help to protect the sign from damage when the internal temperature of the sign is too hot to continue normal operation. The following triggers are used for most models:

- If the internal temperature of the sign goes above the “**cooling fans on**” point, the cooling fans are turned on.
- If the internal temperature reaches the “**dimming on**” point, the LED output from the sign is forced into a 50% reduced-power mode, effectively dimming the brightness of LED output by about 50%.
- If the temperature reaches the “**overheat on**” point, the sign will shut down normal data display to protect the sign from damage. “**OVERHEATED**” will appear in 7-high characters.
- If the temperature returns below the “**overheat off**” point, the overheated message ceases and normal data is displayed at 50% brightness.
- If the temperature returns below the “**dimming off**” point, the forced dimming is turned off and the sign returns to normal processing.
- If the temperature returns below the “**cooling fans off**” point, the cooling fans are turned off.

**Temperature trigger points for NEMA signs**

Triggers	Sign Model			
	4000	7000	2.1"	3.2"
<b>Cooling fans on</b>	---- Not applicable ----		50°C 122°F	50°C 122°F
<b>Dimming on</b>	60°C 140°F	60°C 140°F	65°C 149°F	65°C 149°F
<b>Overheat on</b>	70°C 158°F	70°C 158°F	70°C 158°F	70°C 158°F
<b>Overheat off</b>	65°C 149°F	65°C 149°F	55°C 131°F	55°C 131°F
<b>Dimming off</b>	55°C 131°F	55°C 131°F	50°C 122°F	50°C 122°F
<b>Cooling fans off</b>	---- Not applicable ----		30°C 86°F	30°C 86°F

**NOTE:** Take into account the effects of ambient temperature when evaluating mounting locations for the sign. You should always avoid poorly-ventilated mounting locations that could be subject to radiation, convection, conduction, or other thermal transfer effects.

# Safety

---

## Equipment symbols

---



Chassis ground



Mains power (1 = On, 0 = Off)

## Warnings and Notices

---

**WARNING!** Hazardous voltage. Contact with high voltage may cause death or serious injury. Always disconnect power to unit prior to servicing.

---

Other warnings and notices are posted in appropriate locations throughout this manual.

## Preventing electrostatic discharge damage

---

**Notice:** Alpha signs contain components that may be damaged by electrostatic discharge, or static electricity. To prevent this from happening, follow the guidelines in Adaptive TechMemo 00-0005, “*Preventing Electrostatic Discharge (ESD) Damage*,” available on our Web site at <http://www.adaptivedisplays.com>.

---

## EMI compliance

---

This equipment has been tested and found to comply with the limits for a Class A digital device, pursuant to Part 15 of the FCC Rules. These limits are designed to provide reasonable protection against harmful interference when the equipment is operated in a commercial environment.

This equipment generates, uses, and can radiate radio frequency energy and, if not installed and used in accordance with installation guidelines, may cause harmful interference to radio communications. Operation of this equipment in a residential area is likely to cause harmful interference, in which case the user will be required to correct the interference at his own expense.

---

# Installation

---

---

**WARNING!** Hazardous voltage. Contact with high voltage may cause death or serious injury. Always disconnect power to unit prior to servicing.

---

## Electrical installation guidelines

---

- A readily-accessible disconnect device shall be installed in the fixed wiring supplying power to this equipment. The disconnect device shall have a contact separation of at least 3 mm.
- This equipment relies on protective devices in the building installation for protection for short circuit and/or overcurrent protection. Install this equipment only where these protective devices are present. The size and type of the protective devices shall be appropriate for the voltage and current ratings on this equipment.
- Only qualified personnel should install the Alpha NEMA signs.
- Disconnect power from the sign. Power must be removed from the sign at the power source to prevent electrical injury or damage.
- Alpha NEMA 2, 4, 4X, and 12 signs are for **indoor use only**. Do not continuously expose to direct sunlight.
- Mounting hardware that is used to hang or suspend signs must be capable of supporting **at least 4 times** the total weight of any/all signs mounted together.
- For integrity of the case, do not drill holes in or modify the case.

## Alpha 4000 series NEMA 12 models

Model (weight)	Electrical instructions
<p>N124120x (28 lbs, 12.7 kg)</p> <p>N124240x (50 lbs, 22.7 kg)</p>	<h3 style="margin-top: 0;">Connecting the power wires</h3> <p><b>WARNING!</b> <b>Hazardous voltage. Contact with high voltage may cause death or serious injury. Always disconnect power to unit prior to servicing.</b></p> <ol style="list-style-type: none"> <li>1. Remove the power supply cover by unscrewing its 6 screws. Save the screws for a later step.</li> <li>2. It is recommended that you install power and serial wires at the bottom of the power supply enclosure. However, to accommodate power or serial wire installation at the top of the enclosure, you may want to remove the left or right conduit hole plug from the top of the enclosure by removing its wing nut inside the enclosure. Save the hole plug for a later step. It is also possible, but not recommended, to install the wires in the same way on the left end.</li> <li>3. Insert the power wires through the <i>left</i> conduit on either the top or the bottom of the sign. The bottom conduit is recommended to reduce noise from power wires crossing serial wires.</li> <li>4. Connect the incoming electrical wires.</li> </ol> <p><b>NOTE:</b> Use watertight conduit connectors only. Flexible conduit should be used.</p> <p><b>NOTE:</b> Be sure to place the wires so they will not be caught by screws when replacing the power supply cover, and also so they will not interfere with fan operation.</p>

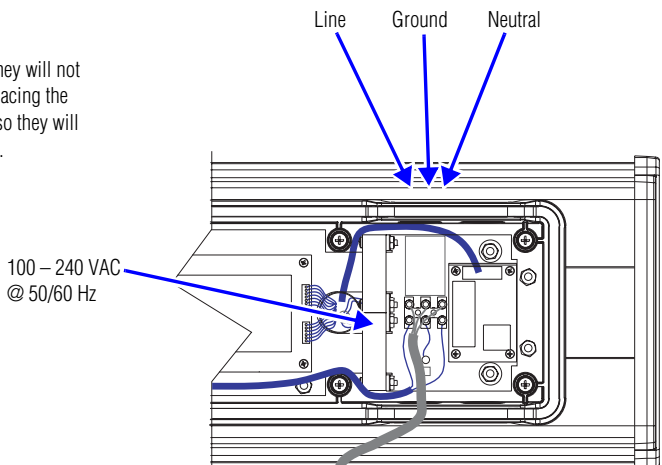
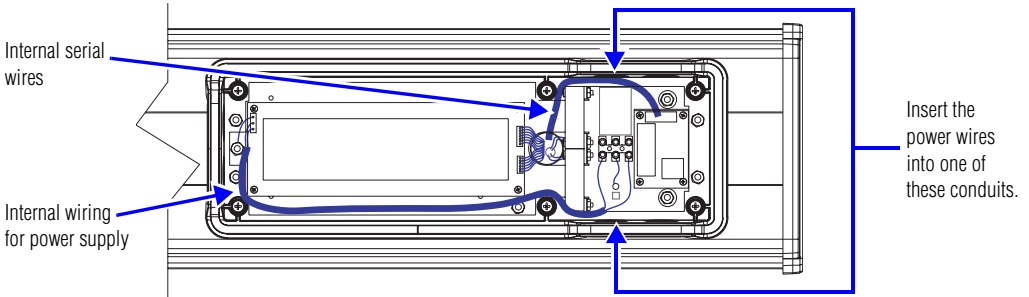
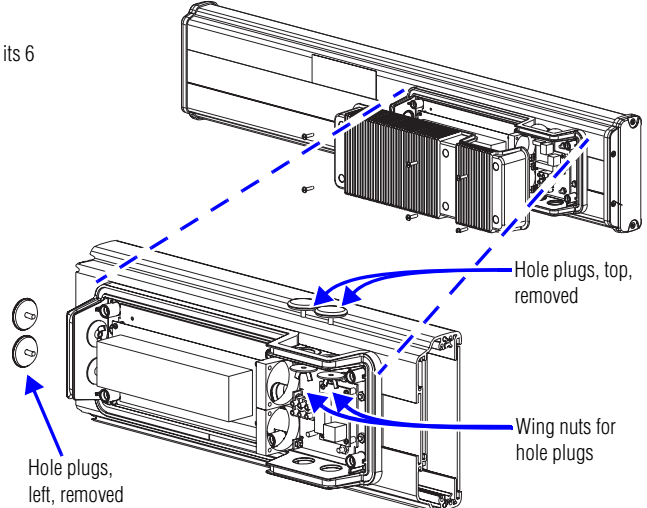

### Alpha 4000 series NEMA 12 models

**Model  
(weight)**

### Electrical instructions

#### Connecting the serial wires

**WARNING!** Hazardous voltage. Contact with high voltage may cause death or serious injury. Always disconnect power to unit prior to servicing.

5. Insert the serial wires through the *right* conduit on either the top or the bottom of the sign.

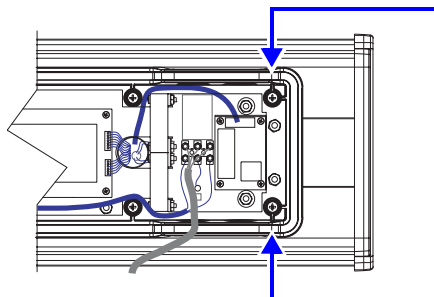

Insert the serial wires into *one* of these conduits.

NOTE: TB1 can be used for incoming bare-wire serial connection for RS232 *or* RS485, plus Auxiliary out. The full pinout diagram is:

TB1 - full			
1 GND	5 RS485+	6 RS485-	7 AUX OUT
2 +5V	6 RS485-	7 AUX OUT	8 SHIELD
3 RS232 TX	7 AUX OUT	8 SHIELD	
4 RS232 RX	8 SHIELD		

6. (Optional) Connect an auxiliary device to TB1.

TB1 - Aux out			
1 GND	5 NC	6 NC	7 AUX OUT
2 NC	6 NC	7 AUX OUT	8 NC
3 NC	7 AUX OUT	8 NC	
4 NC	8 NC		

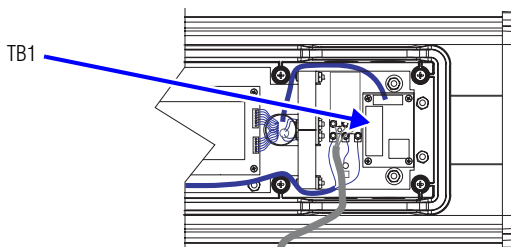

7. Connect the incoming serial wires (*bare-wire connection*).

TB1 can be used for incoming RS232 *or* RS485 serial connection, but not both.

TB1 and RS485 are recommended to reduce undesirable electrical interference.

Aux Out can be used at the same time.

NOTE: Be sure to place the wires so they will not be caught by screws when replacing the power supply cover, and also so they will not interfere with fan operation.

TB1 - RS232				TB1 - RS485			
1 GND	5 NC	1 NC	5 RS485+				
2 NC	6 NC	2 NC	6 RS485-				
3 RS232 TX	7 NC	3 NC	7 NC				
4 RS232 RX	8 NC	4 NC	8 SHIELD				

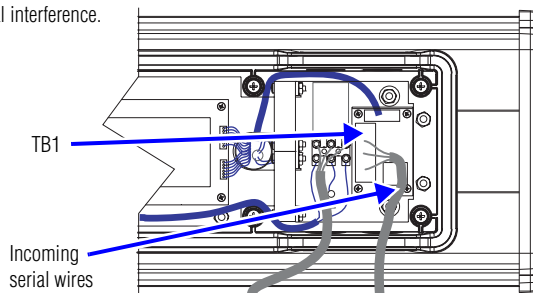

N124120x  
(28 lbs, 12.7 kg)

N124240x  
(50 lbs, 22.7 kg)

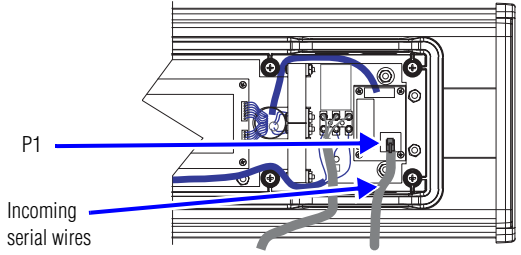
<b>Alpha 4000 series NEMA 12 models</b>	
<b>Model (weight)</b>	<b>Electrical instructions</b>
<p>N124120x (28 lbs, 12.7 kg)</p> <p>N124240x (50 lbs, 22.7 kg)</p>	<p><b>Connecting the serial wires, continued</b></p> <p>8. Connect the incoming serial wires (<i>RJ11/RJ12 connection for RS232 only</i>) P1 can be used for incoming RS232, although it is not recommended.</p> <p>NOTE: Be sure to place the wires so they will not be caught by screws when replacing the power supply cover, and also so they will not interfere with fan operation.</p> <div style="display: flex; align-items: center;"> <div style="margin-right: 20px;"> <p>P1</p> <p>Incoming serial wires</p> </div>  </div> <p>9. To maintain NEMA compliance and to prevent EMI emissions, install hole plugs in any open conduit holes in the power supply enclosure. If needed, there is an extra hole plug supplied in addition to any hole plugs removed in Step 2.</p> <p>10. Replace the power supply cover using the 6 screws from when the cover was removed. (Refer to Step 1.) Torque the screws to 24 lb-in.</p> <p>11. Plug the power cable into a power source.</p>

### Alpha 4000 series NEMA 12 models

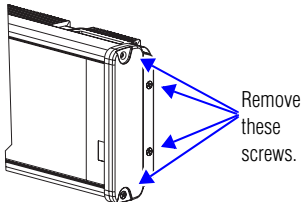
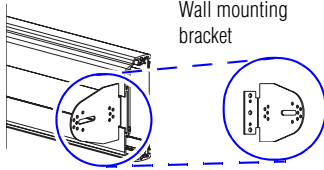
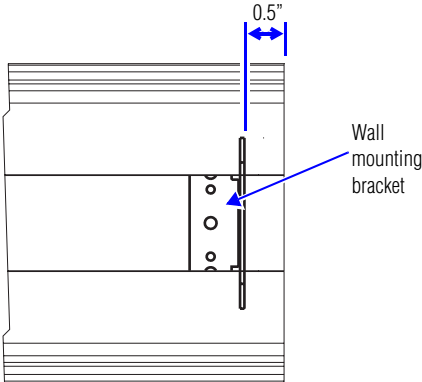
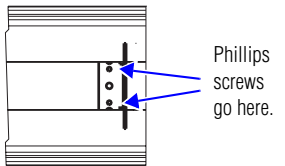
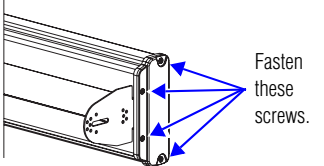
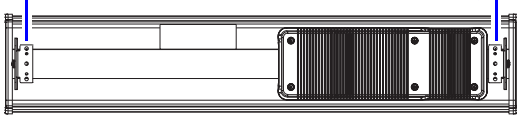
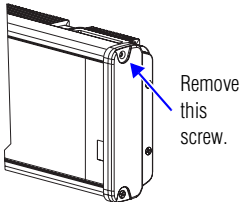
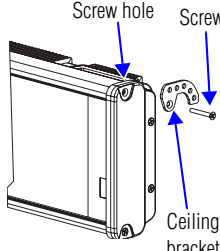
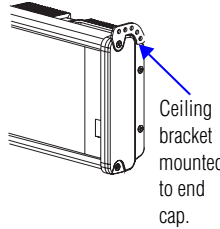
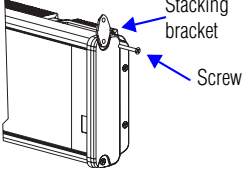
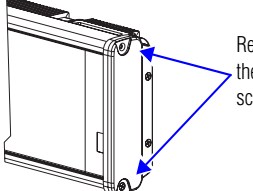
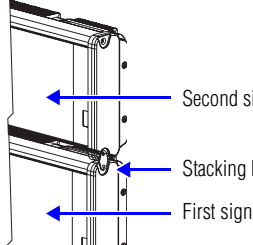
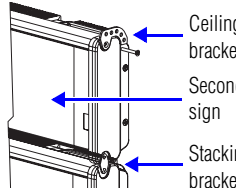
Model (weight)	Mounting instructions		
	Wall	Ceiling	Stacking
N124120x (28 lbs, 12.7 kg)  N124240x (50 lbs, 22.7 kg)	<p><b>NOTE: Remove only one end cap at a time.</b></p> <p>1. Remove the 4 screws and the end cap from one end of the sign.</p>  <p>Remove these screws.</p> <p>2. Slide one of the wall mounting brackets onto the back of the sign until it is approximately 0.5 in. away from the end of the sign.</p>  <p>Wall mounting bracket</p>  <p>0.5"</p> <p>Wall mounting bracket</p> <p>3. Use two 10-32 x 1/4 Phillips screws (supplied) to secure the wall mounting bracket to the back of the sign. Torque the screws to 24 lb-in.</p>  <p>Phillips screws go here.</p> <p>4. Replace the end cap using the 4 screws removed in Step 1. Torque the screws to 24 lb-in.</p>  <p>Fasten these screws.</p> <p>5. Repeat Steps 1 - 4 for the other end of the sign. Distances between the bracket holes, center-to-center, should be approximately:</p> <p>N124120x: 37" (94 cm) N124240x: 73" (185.4 cm)</p> 	<p>1. Remove one screw from the top of the end cap.</p>  <p>Remove this screw.</p> <p>2. Line up a ceiling bracket with the top hole on the sign's end cap so the bracket fits in the indentation. There are left and right ceiling brackets. Use the one that fits with the screw hole's countersunk side facing out. Secure the ceiling bracket with the screw removed in Step 1. Torque the screws to 24 lb-in.</p>  <p>Screw hole</p> <p>Screw</p> <p>Ceiling bracket</p>  <p>Ceiling bracket mounted to end cap.</p> <p>3. Repeat Steps 1 - 2 for the other end of the sign.</p> <p>4. Use chains (not supplied) to hang the sign from a ceiling.</p> <p><b>NOTE:</b> Use chains capable of supporting 4 times the total weight of the sign(s).</p> <p><b>NOTE:</b> The hole you select in the ceiling bracket for the chain determines the angle at which the sign hangs.</p>	<p><b>NOTE:</b> Up to 4 signs can be hung together vertically (stacked). Mounting system for stack mounting must support a minimum of four times the total weight of all signs being stacked.</p> <p><b>WARNING! Possible crush hazard. Do not stack more than 4 signs. Otherwise signs may fall causing serious injury or death.</b></p> <p>1. Remove the top screw from each end cap of the first sign, as shown in Step 1 of the Ceiling mounting instructions.</p> <p>2. Using the screw removed in Step 1, screw a stacking bracket to each end cap, countersunk side out. Torque to 24 lb-in.</p>  <p>Stacking bracket</p> <p>Screw</p> <p>3. Remove the top and bottom screws from each end of the second sign.</p>  <p>Remove these screws.</p> <p>4. For each end of the signs, secure the stacking bracket from the first sign to the second sign using one of the screws removed in Step 3. Torque to 24 lb-in.</p>  <p>Second sign</p> <p>Stacking bracket</p> <p>First sign</p> <p>5. Secure a ceiling bracket to the top of each end cap on the second sign, using Step 2 of the ceiling mounting instructions.</p>  <p>Ceiling bracket</p> <p>Second sign</p> <p>Stacking bracket</p> <p>6. Use a chain (not supplied) to hang the signs from the ceiling, following the notes in Step 4 of ceiling mounting instructions.</p>
	<i>Continued on next page</i>		

### Alpha 4000 series NEMA 12 models

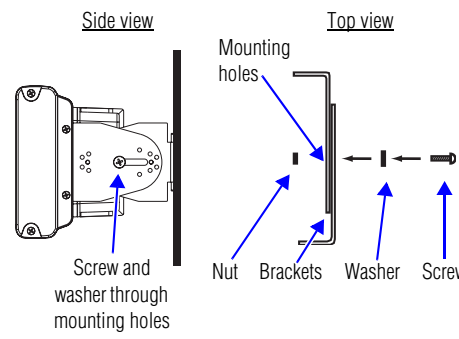
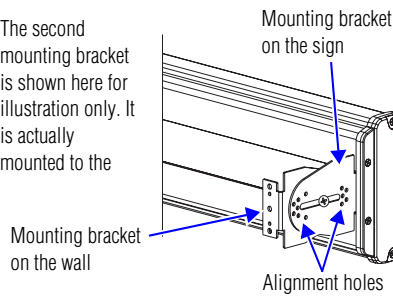
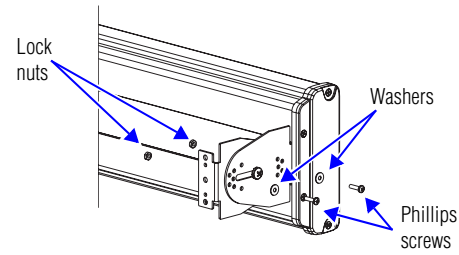
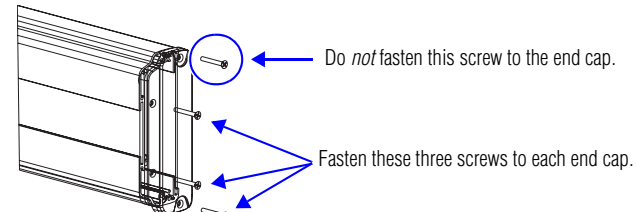
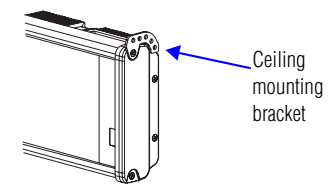
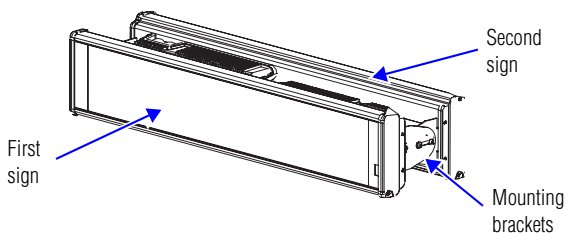
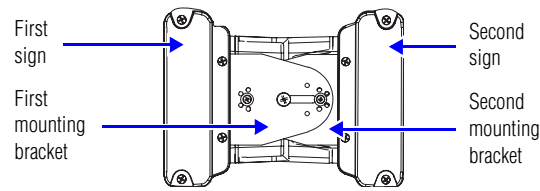
Model (weight)	Mounting instructions	
	Wall (continued)	Back-to-Back
<p>N124120x (28 lbs, 12.7 kg)</p> <p>N124240x (50 lbs, 22.7 kg)</p>	<p>6. Attach the two remaining wall mounting brackets to a wall so that they align with the brackets on the sign.</p> <p>NOTE: Do <i>not</i> install the sign directly to drywall or plaster-board. The sign must be fastened to a wall capable of supporting at least four times the weight of the sign.</p> <p>7. Connect the mounting brackets on each end of the sign together using a 5/16 Phillips screw and a 5/16 washer through the mounting holes, as shown below, securing with a 5/16 nut. <i>Do not tighten the nut at this time.</i></p>  <p>8. Match the alignment holes of the brackets on the sign with the alignment holes of the brackets on the wall so that the sign is at the desired viewing angle.</p> <p>NOTE: The second mounting bracket is shown here for illustration only. It is actually mounted to the</p>  <p>9. Fasten the mounting brackets together using two 10-32 x 3/4 Phillips screws, two 10-32 washers, and two 10-32 lock nuts through selected alignment holes on each end of the sign. Torque to 24 lb-in.</p>  <p>10. Tighten the 5/16 nuts in the mounting holes. (See Step 7.) Torque to 24 lb-in.</p>	<p><b>NOTE: Remove only one end cap at a time for each sign.</b></p> <p>1. Attach a mounting bracket on each end of the signs and replace the end caps, following Steps 1 - 4 of the wall mounting instructions. However, <i>replace only the bottom three screws</i> for each end cap. Torque the screws to 24 lb-in. Do this step for each end of both signs.</p> <p>NOTE: Do <i>not</i> fasten the <i>top</i> screws to the end caps. The top screws will be used to fasten the ceiling mounting brackets to the end caps in the next step.</p>  <p>2. Attach ceiling mounting brackets to all the end caps following Step 2 of the ceiling mounting instructions. Torque the screws to 24 lb-in.</p>  <p>3. Match the signs together back-to-back. Connect them together following Steps 7 - 9 of the wall mounting instructions. Torque to 24 lb-in.</p>   <p>4. Use chains (not supplied) to hang the signs from the ceiling.</p> <p>NOTE: Use chains capable of supporting 4 times the total weight of the signs.</p>

### Alpha 7000 series NEMA 4 and 4x models

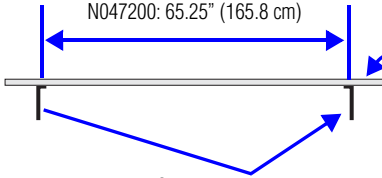
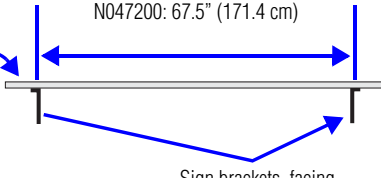
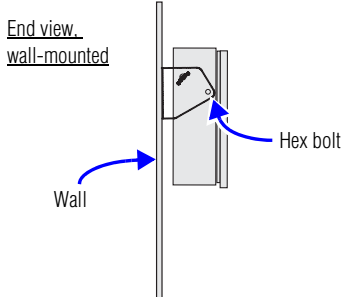
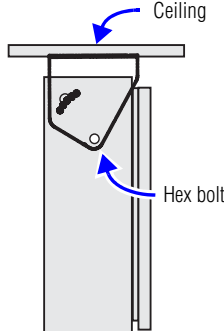
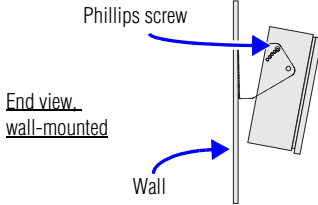
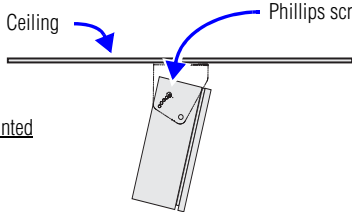
Model (weight)	Mounting instructions
<p>N047120C (60 lbs, 27.2 kg)</p> <p>N047160C (70 lbs, 31.8 kg)</p> <p>N047200C (80 lbs, 36.3 kg)</p>	<p>1. Attach the two sign brackets to a wall, ceiling, or other surface. Be sure to place the brackets so the bracket flanges face appropriately as shown below. Mount the brackets the following distance apart (measured from the center of the mounting holes in each bracket):</p> <div style="display: flex; justify-content: space-around;"> <div style="text-align: center;"> <p><i>Mounted so flanges are hidden behind the sign</i></p> <p>N047120: 41.25" (104.8 cm) N047160: 53.25" (135.3 cm) N047200: 65.25" (165.8 cm)</p>  <p>Sign brackets, facing in behind the sign</p> </div> <div style="text-align: center;"> <p><i>Mounted so flanges show on the sides of the sign</i></p> <p>N047120: 43.5" (110.5 cm) N047160: 55.5" (141 cm) N047200: 67.5" (171.4 cm)</p>  <p>Sign brackets, facing out from the sign</p> </div> </div> <p>NOTE: Do <i>not</i> install the sign directly to drywall or plasterboard. The sign must be fastened to a surface capable of supporting at least four times the weight of the sign.</p> <p>2. Mount the sign on the sign brackets using the two large hex bolts supplied.</p> <div style="display: flex; justify-content: space-around;"> <div style="text-align: center;"> <p><u>End view.</u> wall-mounted</p>  <p>Hex bolt</p> <p>Wall</p> </div> <div style="text-align: center;"> <p><u>End view.</u> ceiling-mounted</p>  <p>Hex bolt</p> <p>Ceiling</p> </div> </div> <p>3. Tilt the sign to select a viewing angle. To hold the sign in place, screw a Phillips screw (supplied) through one of the small holes on each bracket into the screw hole in the sign case.</p> <div style="display: flex; justify-content: space-around;"> <div style="text-align: center;"> <p><u>End view.</u> wall-mounted</p>  <p>Phillips screw</p> <p>Wall</p> </div> <div style="text-align: center;"> <p><u>End view.</u> ceiling-mounted</p>  <p>Phillips screw</p> <p>Ceiling</p> </div> </div> <p>NOTE: Keep a minimum 1.0-inch (2.54 cm) clearance on all sides of the sign for adequate ventilation.</p>

### Alpha 7000 series NEMA 4 and 4x models

Model (weight)	Electrical instructions — power supply
-------------------	--

**WARNING!** **Hazardous voltage. Contact with high voltage may cause death or serious injury. Always disconnect power to unit prior to servicing.**

1. Open the front of the sign case by turning the quarter-turn latches counter-clockwise with a large screwdriver. (On the N047120, there are 3 quarter-turn latches; on the N047160 and the N047200, there are 4.) Carefully let the front of the case drop forward.

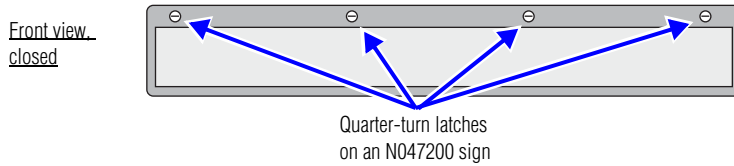

2. Feed electrical cable through 1" water-tight conduit, the outside end of the connector (supplied), the electrical opening in the sign case, and then through the inside end of the connector. Screw the inside and outside ends of the connector together until water-tight.

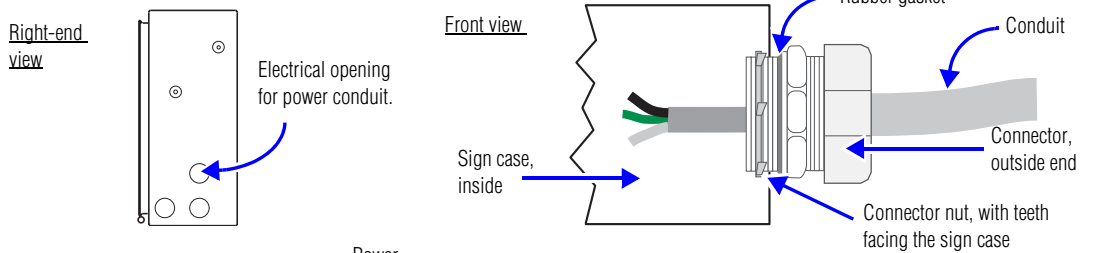

N047120C  
(60 lbs, 27.2 kg)

N047160C  
(70 lbs, 31.8 kg)

N047200C  
(80 lbs, 36.3 kg)

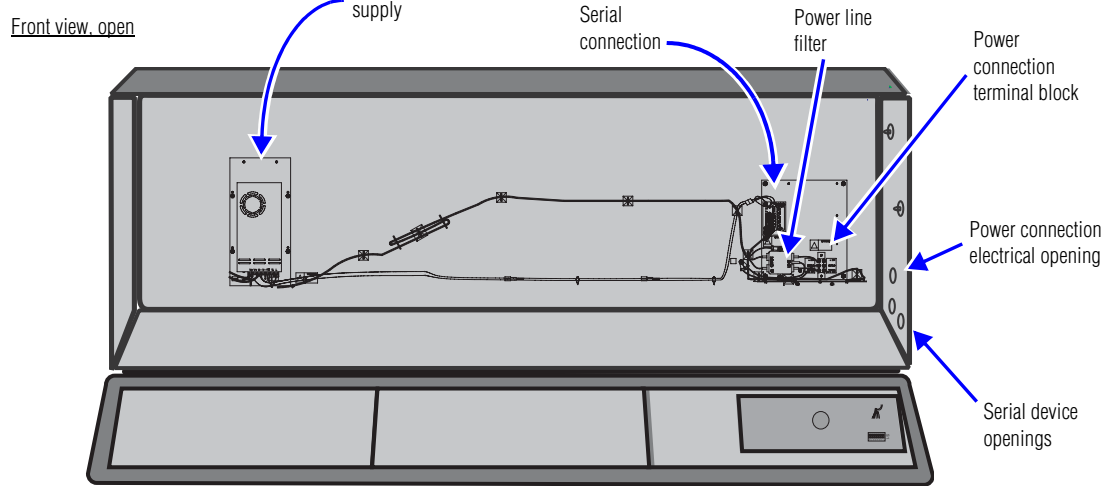

3. Strip the electrical wires back 1/4". Connect the wires by screwing the end of each wire into the power connection.

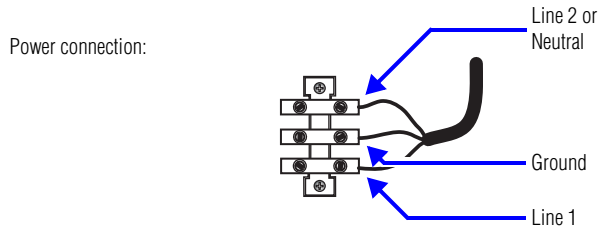

### Alpha 7000 series NEMA 4 and 4x models

**Model  
(weight)**

### Electrical instructions — serial communication

- For serial communications, remove one of the hole plugs from the lowest holes on the right end of the sign case.
- Feed the serial cable from the PC through the serial opening in the sign case.

Right-end  
view

Serial device  
hole plugs

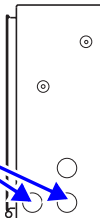

- Connect the incoming serial wires (*bare-wire connection*).  
TB1 can be used for incoming RS485 *or* RS232 serial connection, but not both.  
TB1 and RS485 are recommended to reduce undesirable electrical interference.  
Aux Out can be used at the same time. (See next page.)

NOTE: Be sure to place the wires so they will not be caught when the front of the sign is closed.

NOTE: TB1 can be used for incoming bare-wire serial connection for RS232 *or* RS485, plus Auxiliary Out. The full pinout diagram is:

TB1 - full

1 GND	5 RS485+
2 +5V	6 RS485-
3 RS232 TX	7 AUX OUT
4 RS232 RX	8 SHIELD

N047120C  
(60 lbs, 27.2 kg)

N047160C  
(70 lbs, 31.8 kg)

N047200C  
(80 lbs, 36.3 kg)

1 NC	5 RS485+
2 NC	6 RS485-
3 NC	7 NC
4 NC	8 SHIELD

RS485  
connection  
to TB1

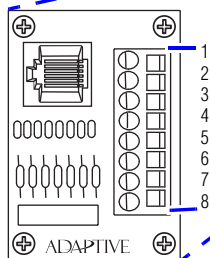

Incoming serial wires

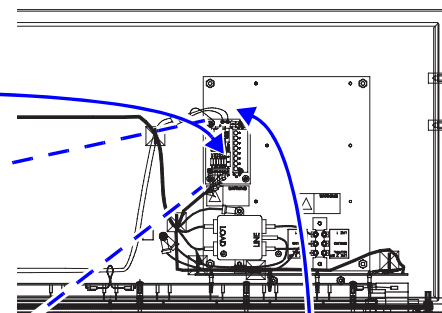

1 GND	5 NC
2 NC	6 NC
3 RS232 TX	7 NC
4 RS232 RX	8 NC

RS232  
connection  
to TB1

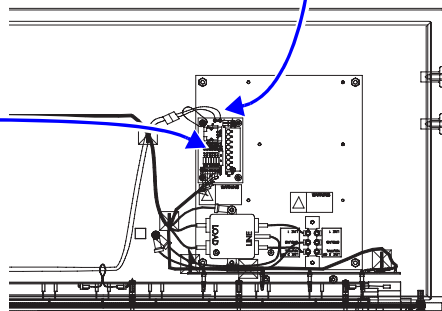

### Alpha 7000 series NEMA 4 and 4x models

#### Connecting the serial wires

7. Connect the incoming serial wires (RJ11/RJ12 connection for RS232 only)

P1 can be used for incoming RS232, although it is not recommended.

NOTE: Be sure to place the wires so they will not be caught when the front of the sign is closed.

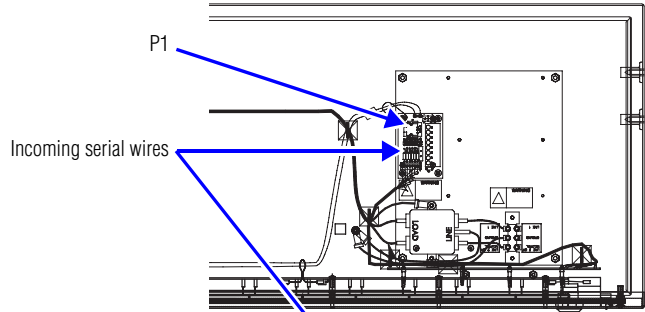

N047120C  
(60 lbs, 27.2 kg)

N047160C  
(70 lbs, 31.8 kg)

N047200C  
(80 lbs, 36.3 kg)

8. (Optional) Connect an auxiliary device to TB1.

TB1 - Aux out			
1	GND	5	NC
2	NC	6	NC
3	NC	7	AUX OUT
4	NC	8	NC

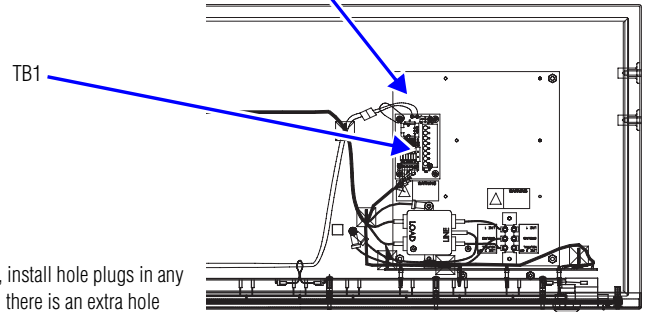

9. To maintain NEMA compliance and to prevent EMI emissions, install hole plugs in any open conduit holes in the power supply enclosure. If needed, there is an extra hole plug supplied in addition to any hole plugs removed in Step 4.

10. Carefully close the front of the sign case and turn the quarter-turn latches clockwise with a large screwdriver.

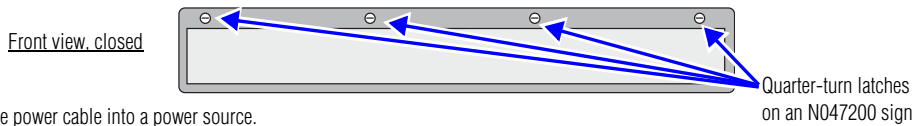

11. Plug the power cable into a power source.

#### Changing the serial address on Alpha 7000 signs

N047120C  
(60 lbs, 27.2 kg)

N047160C  
(70 lbs, 31.8 kg)

N047200C  
(80 lbs, 36.3 kg)

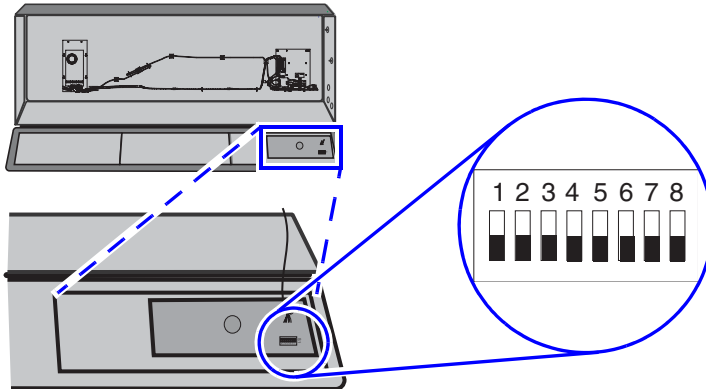

All signs leave the factory with a serial address of 00 (all DIP switches set to OFF), to allow sending the same message to all signs on a network simultaneously.

There are two ways to change a sign's serial address:

1. Use a hand-held infrared Remote Control, as described on page 2.
2. Set a permanent address by accessing the bank of DIP switches located on the micro controller board inside the sign as shown above. (This method will survive power supply interruptions or other conditions that could cause a software-set address to reset.) Close the sign after the address has been reset.

Serial address (in decimal)	DIP switch (1 = ON, 0 = OFF)							
	8	7	6	5	4	3	2	1
00	0	0	0	0	0	0	0	0
01	0	0	0	0	0	0	0	1
02	0	0	0	0	0	0	1	0
03	0	0	0	0	0	0	1	1
04	0	0	0	0	0	1	0	0
05	0	0	0	0	0	1	0	1
06	0	0	0	0	0	1	1	0
07	0	0	0	0	0	1	1	1
08	0	0	0	0	1	0	0	0
09	0	0	0	0	1	0	0	1
10	0	0	0	0	1	0	1	0
11	0	0	0	0	1	0	1	1

## 2.1" NEMA 2 character matrix signs

**Model  
(weight)**

### Wall mounting instructions

1. **Note: chain hanging is not recommended.**
2. **After unpacking the unit, select wall and mounting hardware that is capable of supporting at least four times the weight of the sign, and use 16 bolts to mount the sign.**
3. Use the following table to determine mounting distances for the various models:

Mounting dimensions in inches (centimeters)			
Dimension	Model		
	N02CM040008P03TRI	N02CM040012P03TRI	N02CM040016P03TRI
<b>A</b>	86.45 (219.5)	86.45 (219.5)	86.43 (219.5)
<b>B</b>	82.06 (208.4)	82.06 (208.4)	82.05 (208.4)
<b>C</b>	78.06 (198.3)	78.06 (198.3)	78.05 (198.2)
<b>D</b>	7.64 (19.4)	7.64 (19.4)	7.64 (19.4)
<b>E</b>	46.02 (116.9)	59.22 (150.4)	72.32 (183.7)
<b>F</b>	41.63 (105.7)	54.83 (139.3)	67.94 (172.6)
<b>G</b>	37.63 (95.6)	50.83 (129.1)	63.94 (162.4)

NOTE: The sign shown below is a N02CM040016P03TRI model.

NOTE: Eyebolts are provided only to aid in lifting the sign.

N02CM040008  
P03TRI  
(256 lbs, 116 kg)

N02CM040012  
P03TRI  
(288 lbs, 130.5 kg)

N02CM040016  
P03TRI  
(320 lbs, 145 kg)

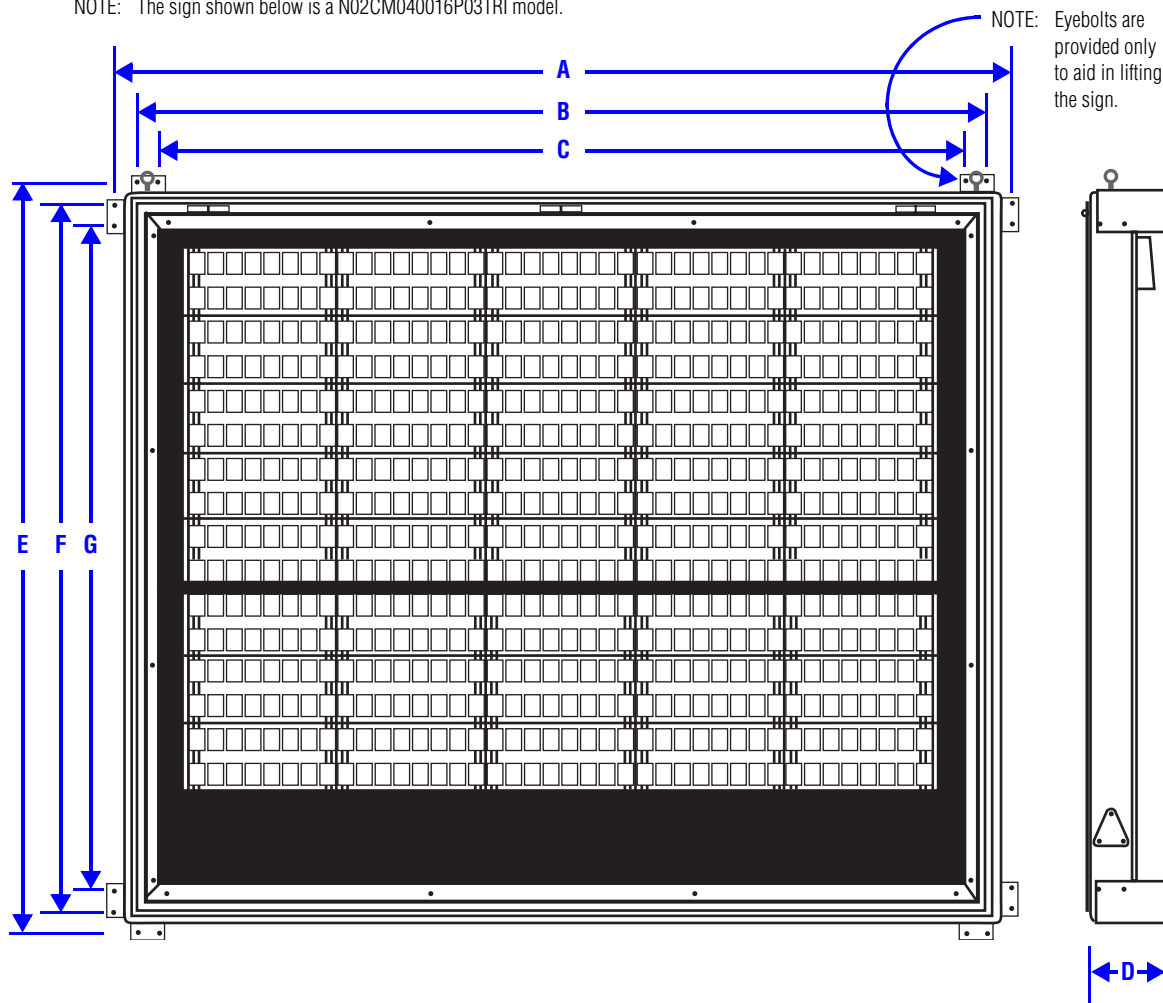

## 2.1" NEMA 2 character matrix signs

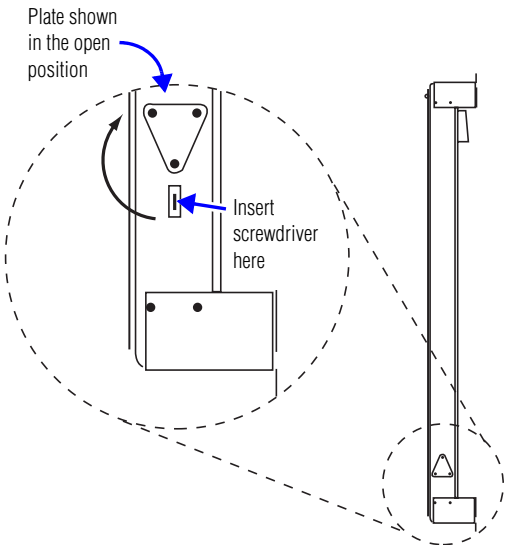
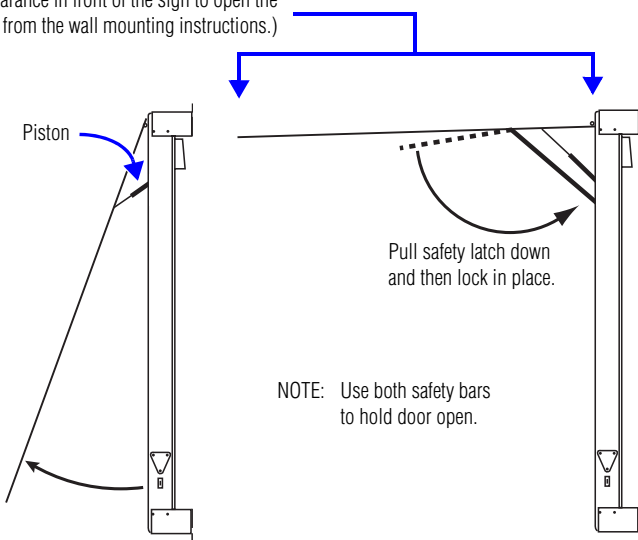
Model (weight)	Electrical instructions
	<p><b>WARNING!</b> <b>Hazardous voltage. Contact with high voltage may cause death or serious injury. Always disconnect power to unit prior to servicing.</b></p> <p><b>Possible crush hazard. Engage safety bar while access door is opened. Otherwise, door may close unexpectedly, possibly causing serious injury.</b></p> <hr/> <p>1. After wall mounting the unit as previously described, remove the two lower screws from the triangular plate on each side of the sign. Swing each plate up. Then use a screwdriver to push up the lever on each side of the sign to unlock the latches for the front access door.</p> <p>NOTE: To close the access door, push the door down until each latch clicks twice.</p> <div style="text-align: center;">  </div> <p>2. Pull the access door up. There will be moderate resistance in lifting the door until the pistons engage. Then pull down and lock the safety latch on each side of the door.</p> <p>NOTE: Use two people (for maneuverability) to open the access door, and use both safety bars to hold the door open.</p> <p>Make sure there is adequate clearance in front of the sign to open the access door. (Use dimension <b>E</b> from the wall mounting instructions.)</p> <div style="text-align: center;">  </div>
<p>N02CM040008 P03TRI (256 lbs, 116 kg)</p>	
<p>N02CM040012 P03TRI (288 lbs, 130.5 kg)</p>	
<p>N02CM040016 P03TRI (320 lbs, 145 kg)</p>	

## 2.1" NEMA 2 character matrix signs

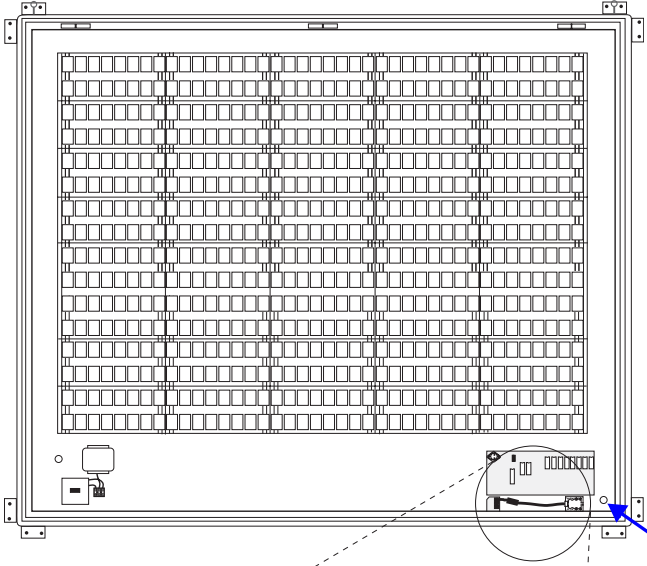
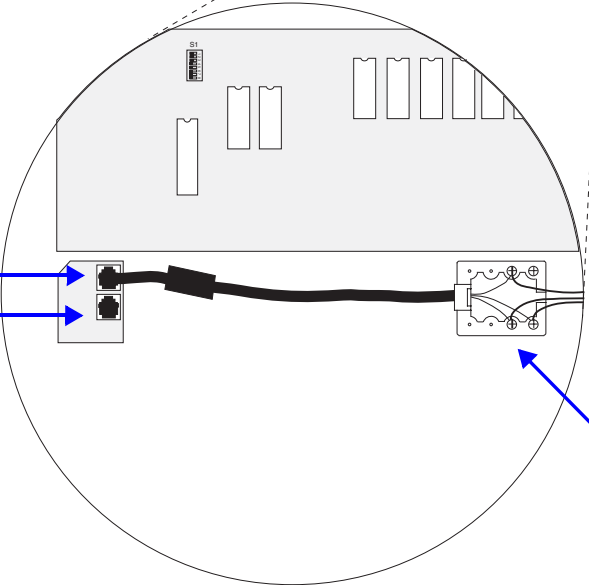
Model (weight)	Electrical instructions (continued)
<p>N02CM040008 P03TRI (256 lbs, 116 kg)</p> <p>N02CM040012 P03TRI (288 lbs, 130.5 kg)</p> <p>N02CM040016 P03TRI (320 lbs, 145 kg)</p>	<p>3. Connect the serial data lines as shown below.</p> <p>NOTE: For further information on connecting a sign to a computer, refer to <b>Networking Alpha Signs</b> (pn 9700-0112).</p> <p>NOTE: Use separate conduits for the signal and power wires. Use watertight connectors for the conduit.</p> <div style="text-align: center; margin: 20px 0;">  </div> <div style="text-align: center; margin: 20px 0;">  </div> <p>Typically, the <b>RS485</b> jack is used when the sign will be connected to a network of <i>multiple</i> signs.</p> <p>The <b>RS485/RS232</b> jack is used when the sign will be connected directly to a computer (and not to other signs).</p>

## 2.1" NEMA 2 character matrix signs

**Model  
(weight)**

### Electrical instructions (continued)

4. Connect the sign to a power supply as shown below:

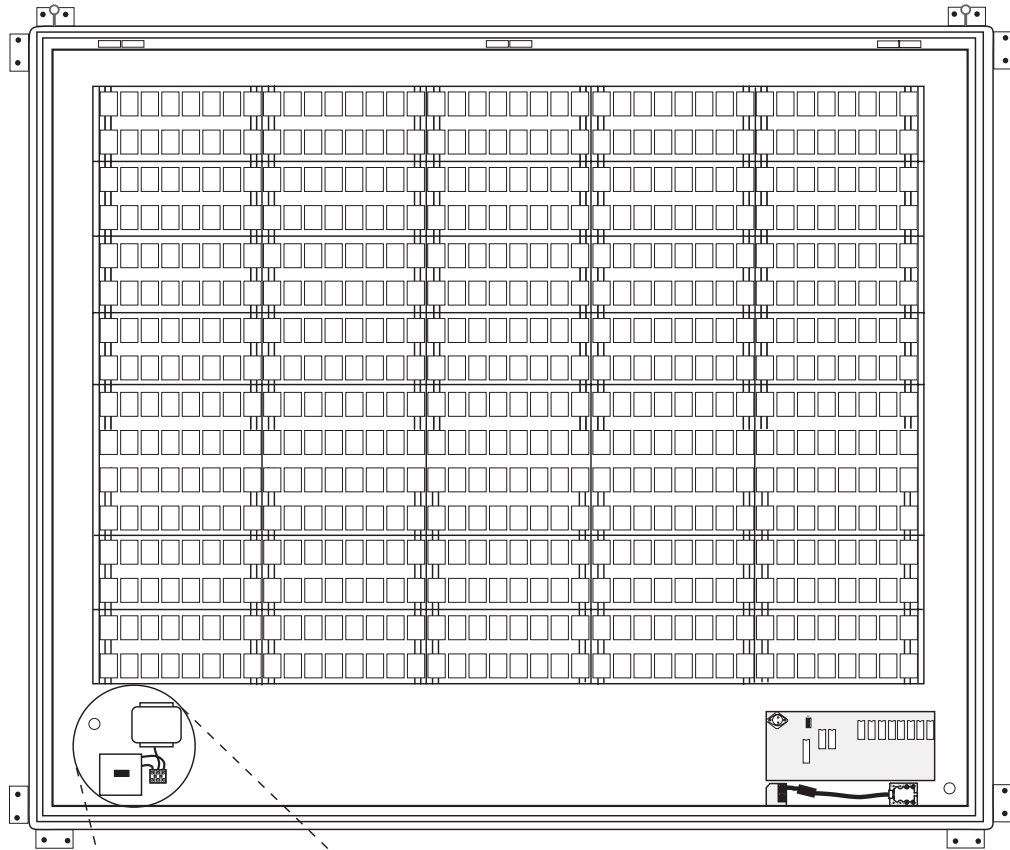

N02CM040008  
P03TRI  
(256 lbs, 116 kg)

N02CM040012  
P03TRI  
(288 lbs, 130.5 kg)

N02CM040016  
P03TRI  
(320 lbs, 145 kg)

Run the power wires out through this 1-1/8-inch (2.86 cm) opening in the sign.

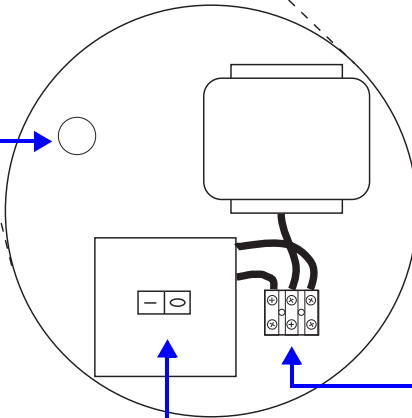

After connecting the power supply lines, move this switch to the ON (I) position.

Connect incoming 208 - 240 +/-5% 50/60 Hz VAC power supply wires (not supplied) to this terminal block as follows:

LINE 1 = Black  
LINE 2 OR NEUTRAL = White  
EARTH GROUND = Green

## 2.1" NEMA 2 character matrix signs

**Model  
(weight)**

### Changing the serial address on 2.1" NEMA 2 signs

1. Remove power from the sign.
2. Open the sign's access door.
3. Then set DIP switch S1 to the desired serial address (see below), a number from 0 to 63 in hexadecimal (00 to 3F), in binary representation. (DIP switch **1** = least significant bit, **6** = most significant bit).
4. After setting the address, apply power to the sign, and the new serial address should appear. (See "Checkout procedure" on page 24.)

N02CM040008  
P03TRI  
(256 lbs, 116 kg)

N02CM040012  
P03TRI  
(288 lbs, 130.5 kg)

N02CM040016  
P03TRI  
(320 lbs, 145 kg)

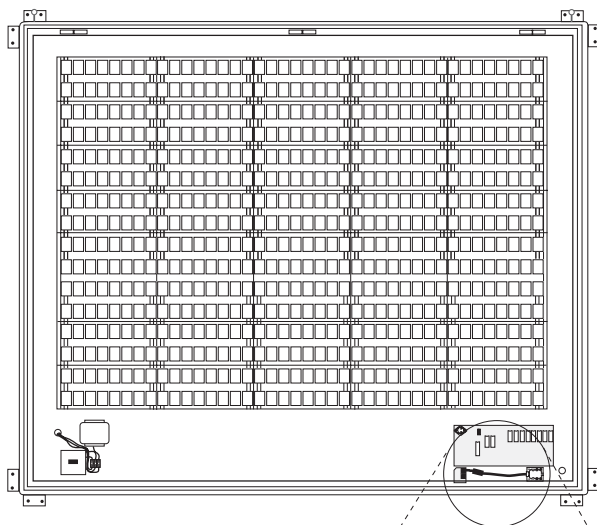

**S1**

DIP switch S1 sets the sign's serial address.  
Here are some example serial addresses:

Serial address in decimal (hexadecimal in parentheses)	DIP switch (1 = ON, 0 = OFF)							
	1	2	3	4	5	6	7	8
0 (00)	0	0	0	0	0	0	0	0
1 (01)	1	0	0	0	0	0	0	0
2 (02)	0	1	0	0	0	0	0	0
3 (03)	1	1	0	0	0	0	0	0
4 (04)	0	0	1	0	0	0	0	0
5 (05)	1	0	1	0	0	0	0	0
6 (06)	0	1	1	0	0	0	0	0
7 (07)	1	1	1	0	0	0	0	0
8 (08)	0	0	0	1	0	0	0	0
9 (09)	1	0	0	1	0	0	0	0
10 (0A)	0	1	0	1	0	0	0	0
11 (0B)	1	1	0	1	0	0	0	0

Do not use

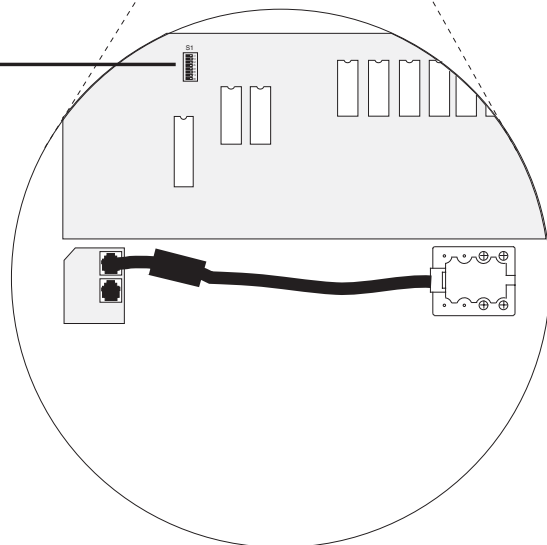
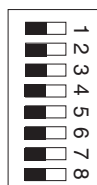

### 3.2" NEMA 2 character matrix signs

**Model  
(weight)**

#### Wall mounting instructions

- Note: chain hanging is not recommended.**
- After unpacking the unit, select wall and mounting hardware that is capable of supporting at least four times the weight of the sign, and use 16 bolts to mount the sign.**
- Use the following table to determine mounting distances for the various models:

Mounting dimensions in inches (centimeters)		
Dimension	Model	
	N02CM040008P045TRI	N02CM040012P045TRI
<b>A</b>	127.66 (324.3)	127.66 (324.3)
<b>B</b>	123.27 (313.1)	123.27 (313.1)
<b>C</b>	119.27 (302.9)	119.27 (302.9)
<b>D</b>	7.64 (19.4)	7.64 (19.4)
<b>E</b>	59.22 (150.4)	79.02 (200.7)
<b>F</b>	54.83 (139.3)	74.63 (189.6)
<b>G</b>	50.83 (129.1)	70.63 (179.4)

N02CM040008  
P045TRI  
(380 lbs, 172.5 kg)

N02CM040012  
P045TRI  
(430 lbs, 195.2 kg)

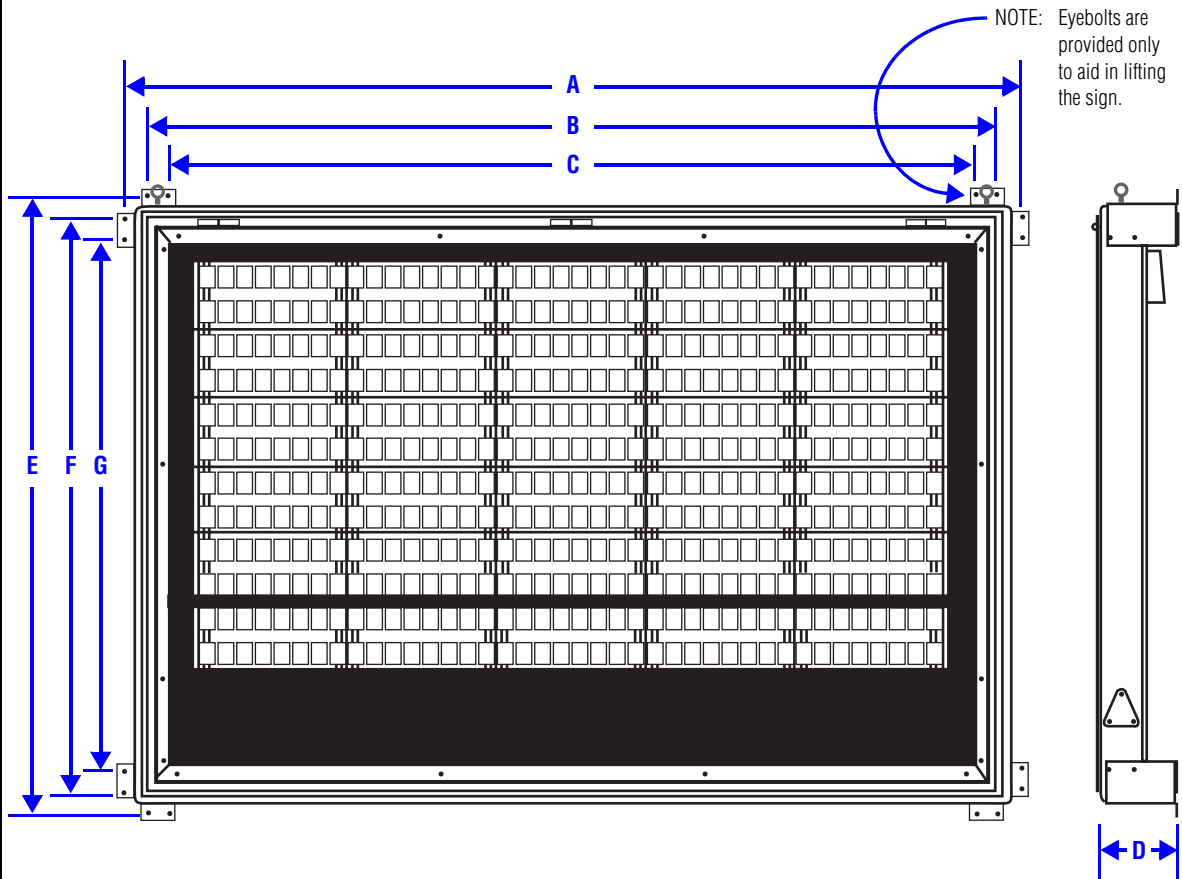

### 3.2" NEMA 2 character matrix signs

**Model (weight)**

#### Electrical instructions

**WARNING!** **Hazardous voltage. Contact with high voltage may cause death or serious injury. Always disconnect power to unit prior to servicing.**  
**Possible crush hazard. Engage safety bar while access door is opened. Otherwise, door may close unexpectedly, possibly causing serious injury.**

1. Remove the two lower screws from the triangular plate on each side of the sign. Swing each plate up. Then use a screwdriver to push up the lever on each side of the sign to unlock the latches for the front access door. There is a third lever in the middle of the bottom of the sign. This needs to be opened and unlocked similarly.

NOTE: To close the access door, push the door down until both latches click twice.

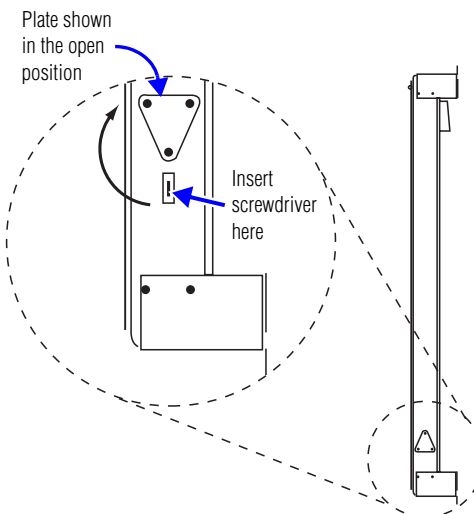

N02CM040008  
P045TRI  
(380 lbs, 172.5 kg)

N02CM040012  
P045TRI  
(430 lbs, 195.2 kg)

2. Pull the access door up. There will be moderate resistance in lifting the door until the pistons engage. Then pull down and lock the safety bar on each side of the door.

NOTE: Use two people (for maneuverability) to open the access door, and use both safety bars to hold the door open.

Make sure there is adequate clearance in front of the sign to open the access door. (Use dimension **E** from the wall mounting instructions.)

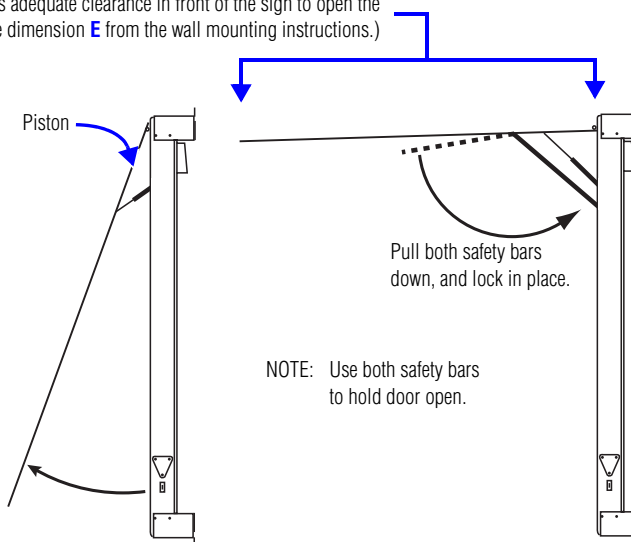

NOTE: Use both safety bars to hold door open.

### 3.2" NEMA 2 character matrix signs

**Model  
(weight)**

**Electrical instructions (continued)**

3. Connect the serial data lines as shown below:

NOTE: For further information on connecting a sign to a computer, refer to **Networking Alpha Signs** (pn 9700-0112.)

NOTE: Use separate conduits for the signal and power wires. Use watertight connectors for the conduit.

N02CM040008  
P045TRI  
(380 lbs, 172.5 kg)

N02CM040012  
P045TRI  
(430 lbs, 195.2 kg)

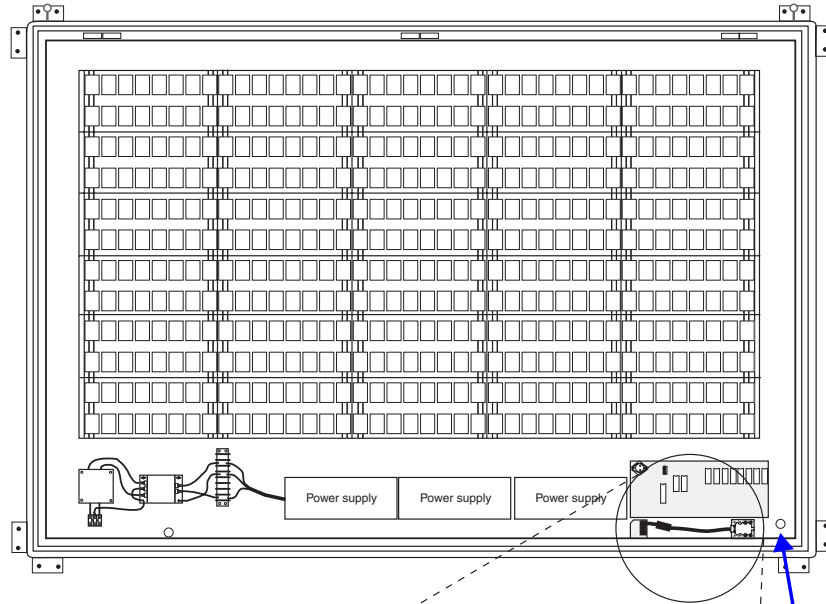

Run the serial wires out through this 1-1/8-inch (2.86 cm) opening in the sign.

**RS485 jack**  
**RS485/RS232 jack**

Typically, the **RS485** jack is used when the sign will be connected to a network of *multiple* signs.

The **RS485/RS232** jack is used when the sign will be connected directly to a computer (and not to other signs).

RS485(+) to terminal with black wire  
RS485(-) to terminal with yellow wire  
SHIELD to terminal with red wire

It is only necessary to connect these wires if the sign will be part of a *network* of signs.

### 3.2" NEMA 2 character matrix signs

**Model  
(weight)**

#### Electrical instructions (continued)

4. Connect the sign to a power supply as shown below:

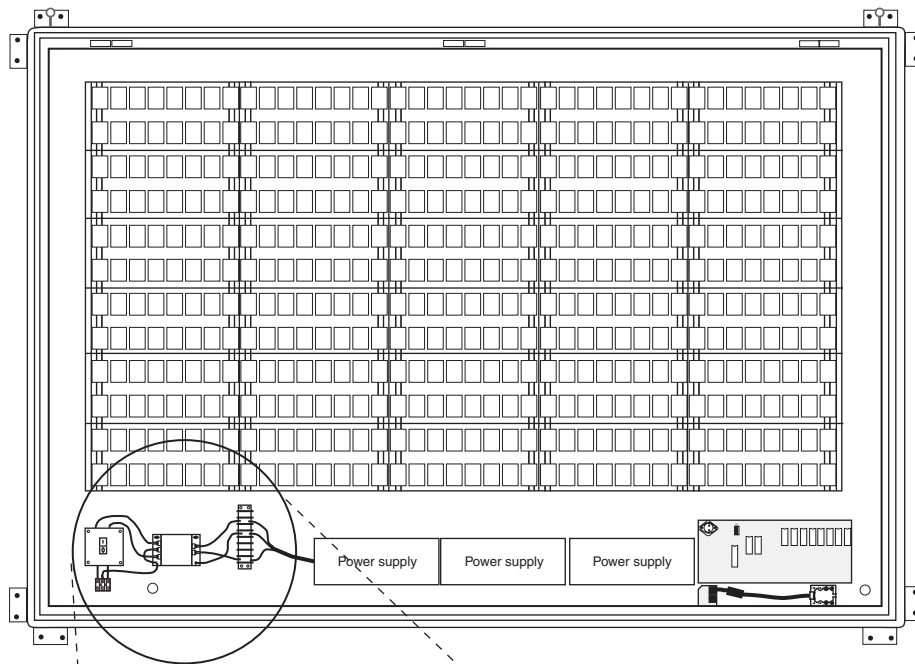

N02CM040008  
P045TRI  
(380 lbs, 172.5 kg)

N02CM040012  
P045TRI  
(430 lbs, 195.2 kg)

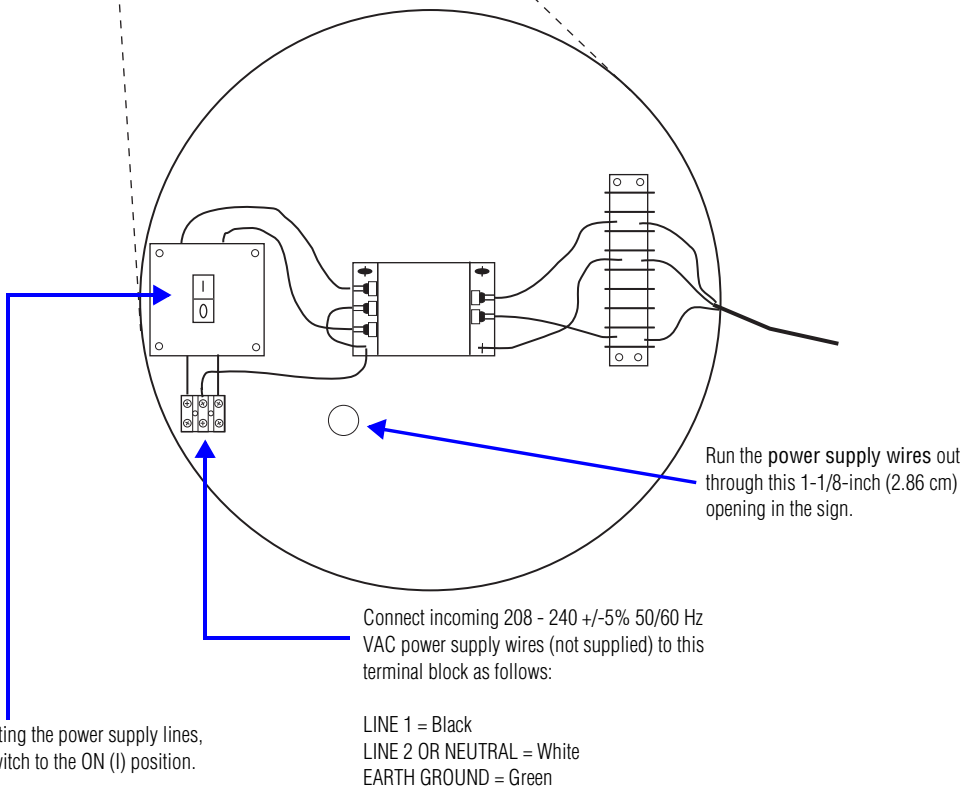

### 3.2" NEMA 2 character matrix signs

**Model (weight)**

#### Changing the serial address on 3.2" NEMA 2 signs

1. Remove power from the sign.
2. Open the sign's access door.
3. Then set DIP switch S1 to the desired serial address (see below), a number from 0 to 63, in binary representation. (DIP switch **1** = least significant bit, **6** = most significant bit).
4. After setting the address, apply power to the sign, and the new serial address should appear. (See "Checkout procedure" on page 24.)

N02CM040008  
P045TRI  
(380 lbs, 172.5 kg)

N02CM040012  
P045TRI  
(430 lbs, 195.2 kg)

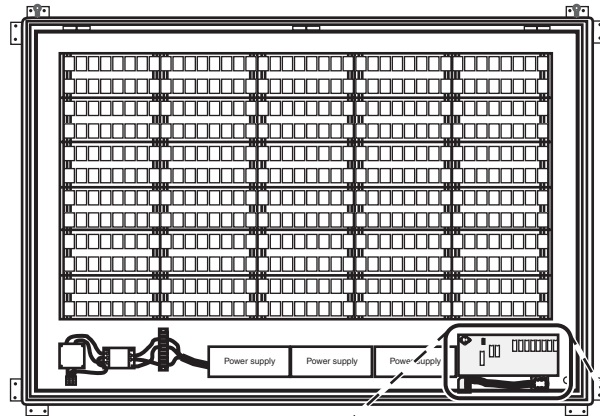

DIP switch S1 sets the sign's serial address. Here are some example serial addresses:

Serial address	DIP switch (1 = ON, 0 = OFF)							
	1	2	3	4	5	6	7	8
0	0	0	0	0	0	0	0	0
1	1	0	0	0	0	0	0	0
2	0	1	0	0	0	0	0	0
3	1	1	0	0	0	0	0	0
4	0	0	1	0	0	0	0	0
5	1	0	1	0	0	0	0	0
6	0	1	1	0	0	0	0	0
7	1	1	1	0	0	0	0	0
8	0	0	0	1	0	0	0	0
9	1	0	0	1	0	0	0	0
10	0	1	0	1	0	0	0	0

Do not use.

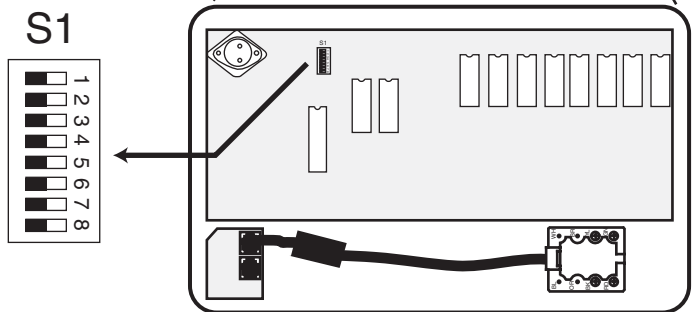

## Checkout procedure

After installing a sign according to the appropriate section on mounting, make sure the sign is installed properly by applying power to it. The following information should appear on the sign:

- firmware part number and version letter (for example, 1018-4403d)
- model number of the sign (for example, N024160C)
- amount of RAM in the sign, (for example, 256K)
- serial address of the sign (a number from 0 to FF or from 000 to 255)