

**1** Disconnect all power from the sign at the power source to prevent electrical injury or damage.

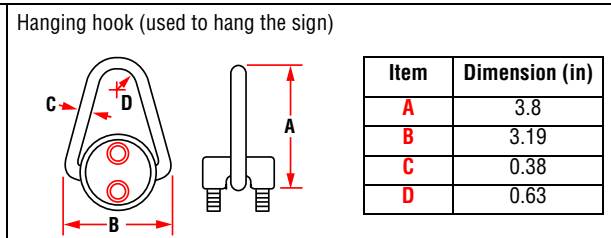

**Sign specifications**

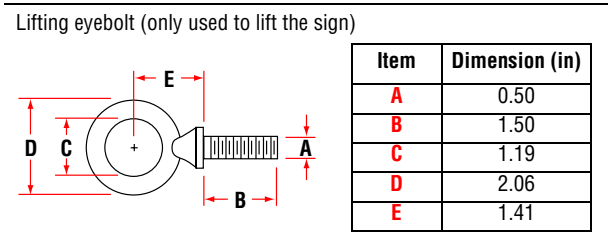
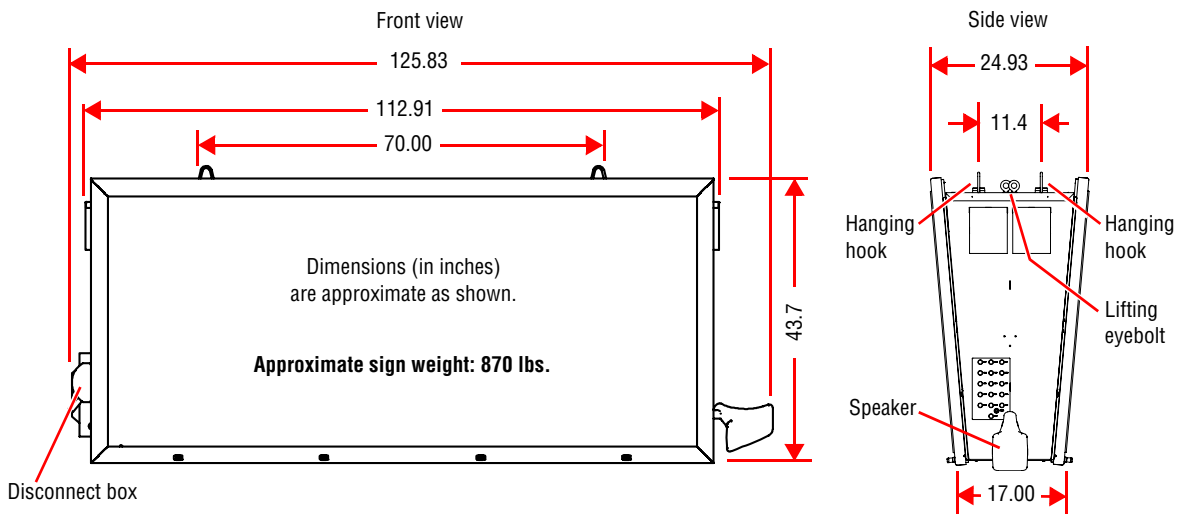

- Design of the support structure should only be done by a qualified individual. It is the installer's responsibility to ensure that the support structure and hardware are capable of safely supporting the sign and are in compliance with all applicable building codes.
- *Adaptive is not responsible for installations or the structural integrity of support structures done by others.*
- Mounting hardware is not supplied with the sign. Mounting hardware that is used to hang or suspend a sign must be capable of safely supporting the weight of the sign (approximately 870 lbs.).
- To avoid damage to the sign, do not place the sign on a flat surface.
- Use the lifting eyebolts or hanging hooks to *lift* the sign.
- However, only use the sign's hanging hooks to *hang* the sign. Mounting to any other parts of the sign will void the warranty. All four hanging hooks must be used to hang the sign.
- These signs are for indoor use only and should not be continuously exposed to direct sunlight, such as in a window.
- These signs should only be used in an environment where the temperature is between 32° and 113° F (0° and 45° C) and non-condensing humidity does not exceed 95%.

Minimum specifications for chain and shackles used to lift and hang a sign:	
Material and finish: selection depends on the specific application. (Plain finish may be used for non-corrosive environments. However, stainless is required for corrosive environments.)	
Working load limit: 2200 lbs.	

## 2 Lift the sign using either the hanging hooks or lifting eyebolts.

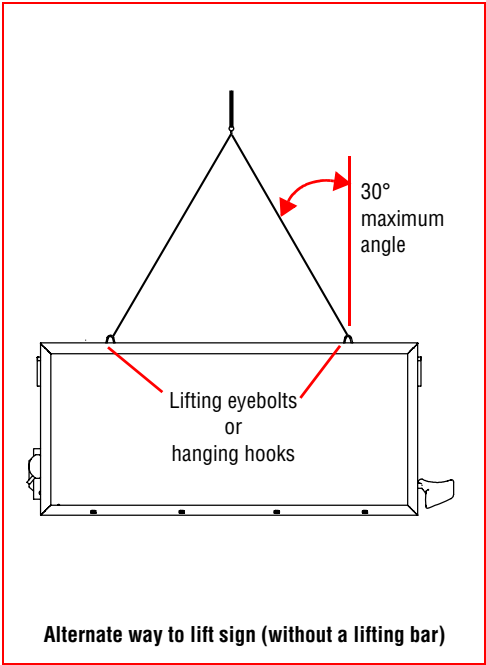
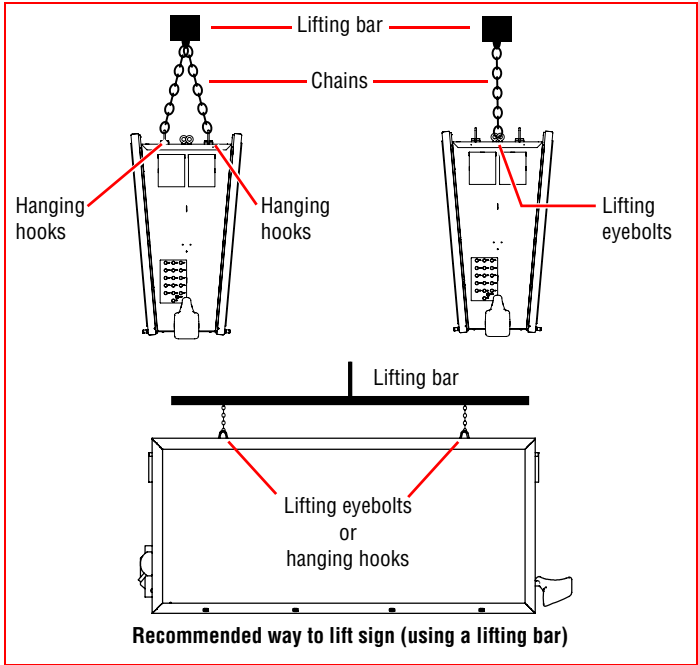

## 3 Hang the sign from chains using all four lifting hooks.

- Hang the sign from all four hanging hooks. Do not hang two chains from the same point.
- Allow minimum clearances as shown below.

