



STEP 1: Sign identification (page 18)

STEP 2: Safety information (page 3)

STEP 3: Mechanical installation (page 4)

STEP 4: Electrical installation (page 7)

STEP 5: Troubleshooting (page 11)

© Copyright 2005 Adaptive Micro Systems LLC. All rights reserved.

Adaptive Micro Systems • 7840 North 86th Street • Milwaukee, WI 53224 USA • 414-357-2020 • 414-357-2029 (fax) • <http://www.adaptivedisplays.com>

Trademarked names appear throughout this document. Rather than list the names and entities that own the trademarks or insert a trademark symbol with each mention of the trademarked name, the publisher states that it is using names for editorial purposes and to the benefit of the trademark owner with no intention of improperly using the trademark.

The following are trademarks of Adaptive Micro Systems: Adaptive, Alpha, AlphaLert, AlphaNET, AlphaNet plus, AlphaEclipse, AlphaEclipse RoadStar, AlphaPremiere, AlphaTicker, AlphaVision, AlphaVision InfoTracker, Automode, BetaBrite, BetaBrite Director, BetaBrite Messaging Software, Big Dot, Director, EZ KEY II, EZ95, PagerNET, PPD, PrintPak, Serial Clock, Smart Alec, Solar, TimeNet.

The distinctive trade dress of this product is a trademark claimed by Adaptive Micro Systems LLC.
Due to continuing product innovation, specifications in this manual are subject to change without notice.

Contents

Introduction	3
Revision history	3
Safety information	3
Controlling electrostatic discharge (ESD)	3
Mechanical installation	4
Guidelines	4
Mounting instructions	5
Electrical installation	7
Troubleshooting	11
Major sign components	11
Problem/Solution chart	14
Appendix	18
Sign identification	18
Sign technical specifications	19
Lifting eyebolt and hanging hook dimensions	20
Controller board jumpers and connectors	21
Advantech PCM-9579 Celeron 650MHz controller board	21
Arcom SBC-GX1 Geode 300MHz controller board	23
Wiring diagrams	28
Advantech PCM-9579 controller board wiring for 320x128 sign	30
Advantech PCM-9579 controller board wiring for 320x112 sign	32
Advantech PCM-9579 controller board wiring for 320x96 sign	34
Advantech PCM-9579 controller board wiring for 320x80	36
Advantech PCM-9579 controller board wiring for 320x64	38
Arcom SBC-GX1 controller board wiring for 320x128	40
Arcom SBC-GX1 controller board wiring for 320x112	42
Arcom SBC-GX1 controller board wiring for 320x96	44
Arcom SBC-GX1 controller board wiring for 320x80	46
Arcom SBC-GX1 controller board wiring for 320x64	48

Introduction

This manual applies to signs that use one of the following controllers:

- Arcom SBC-GX1 300MHz Geode
- Advantech PCM-9579 650MHz Celeron

This manual also applies to the following sign sizes:

- 320 x 128
- 320 x 112
- 320 x 96
- 320 x 80
- 320 x 64

Revision history

Part number	Date	Notes
9713-4012	March 25, 2005	First release.
9713-4012A	May 10, 2005	Added high leakage current warning.

Safety information

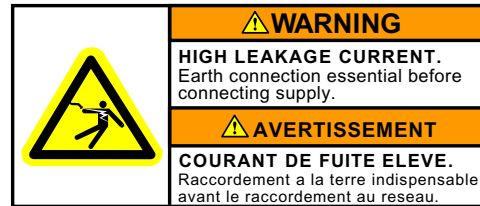
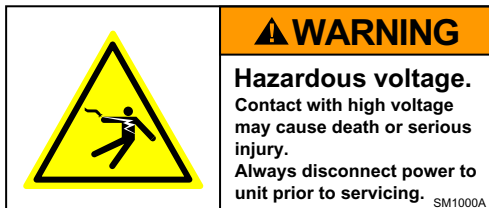

Other safety messages appear in this manual where appropriate.

Controlling electrostatic discharge (ESD)



This equipment contains components that may be damaged by “static electricity”, or electrostatic discharge. To prevent this from happening, be sure to follow the guidelines in Adaptive Tech Memo 00-0005, “Preventing Electrostatic Discharge (ESD) Damage,” available on our Web site at <http://www.adaptivedisplays.com>.

Mechanical installation

Guidelines

- Design of the support structure should only be done by a qualified individual. It is the installer's responsibility to ensure that the support structure and hardware are capable of safely supporting the sign and are in compliance with all applicable building codes.
- *Adaptive is not responsible for installations or the structural integrity of support structures done by others.*
- Mounting hardware is not supplied with the sign. Mounting hardware that is used to hang or suspend a sign must be capable of safely supporting the weight of the sign.
- To avoid damage to the sign, do not place the sign on a flat surface.
- Use the lifting eyebolts *or* the hanging hooks to *lift* the sign.
- Only use the hanging hooks to *hang* the sign. Mounting to any other parts of the sign will void the warranty. All four hanging hooks must be used to hang the sign.
- These signs are for indoor use only and should not be continuously exposed to direct sunlight, such as in a window.
- These signs should only be used in an environment where the temperature is between 32° and 113° F (0° and 45° C) and non-condensing humidity does not exceed 95%.

Mounting instructions

1. Remove power from the sign.



2. Lift the sign using either the hanging hooks or the lifting eyebolts:

NOTE: Eyebolts are not present on all signs.

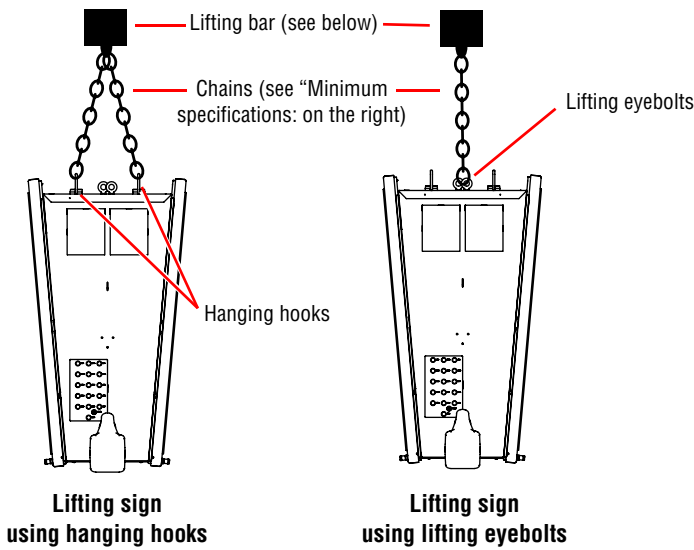

Minimum specifications for chain and shackles used to lift and hang a sign.	
Material and finish:	Selection depends on the specific application. Plain finish may be used for non-corrosive environments. However, stainless steel is required for corrosive environments.
Working load limit:	2200 pounds

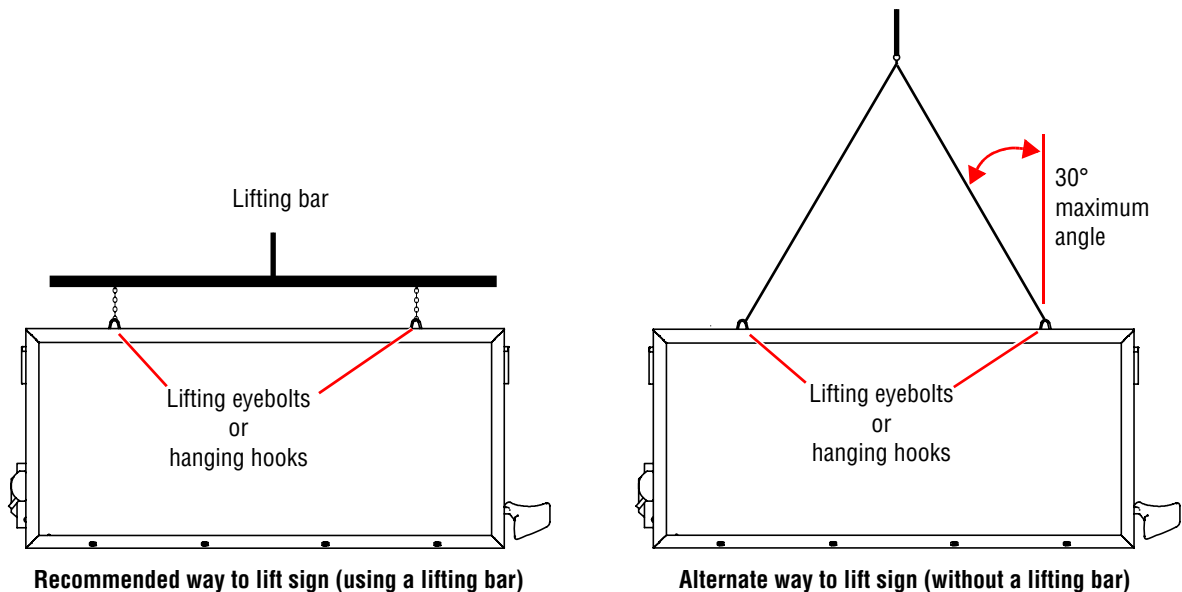

3. Hang the sign from chains using all the lifting hooks:

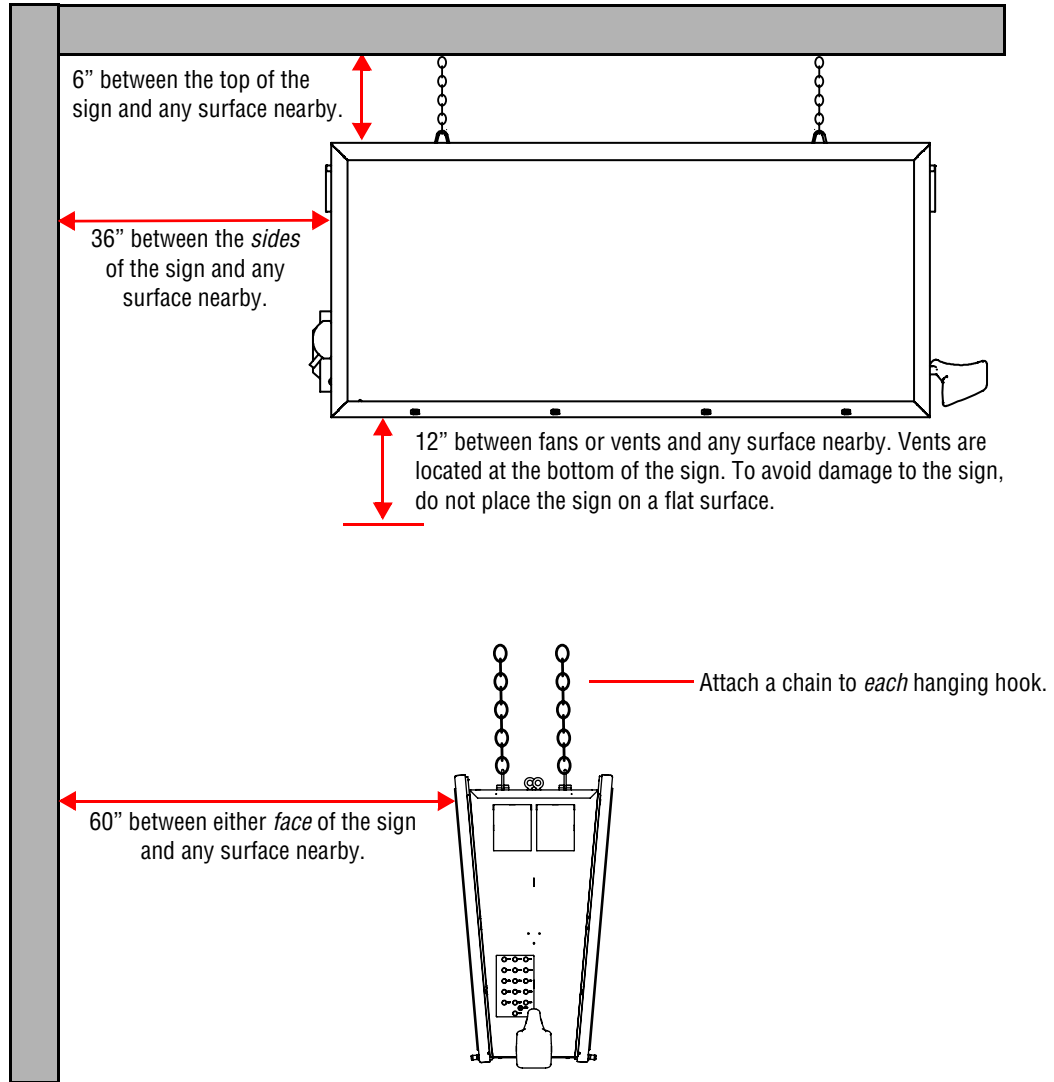

Electrical installation

1. Remove power from the sign.

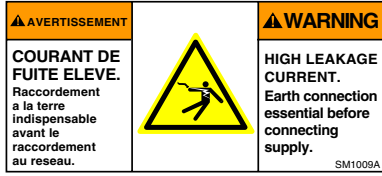

2. This sign should *not* be connected to a ground fault interrupt (GFI) circuit.
3. Open the controller-side sign door.



To open the sign door, turn each door latch (circled) counterclockwise. Then carefully pull the door up.

Then lift the LED driver board panel up by the handle.

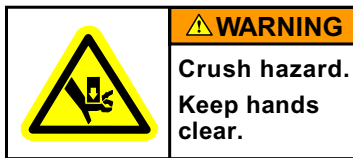
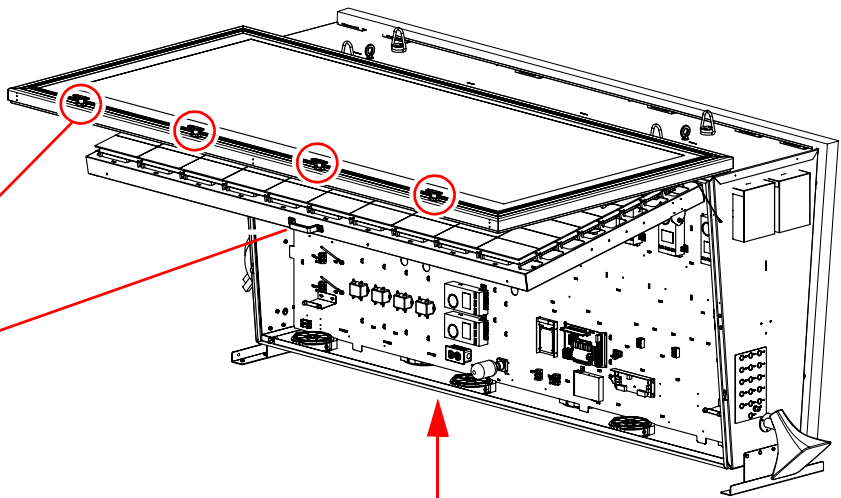

A label like this is located on the bottom of a sign. The arrows on the label point to the controller side of the sign.

4. Connect the sign to an Ethernet network:

- Run Category 5 T568A or T568B wire from the network in the sign communication conduit.
- Position the wires into the channels on the modular network adapter (see below).
- Use a 110 punch-down tool to push the wires into the channels. (Note that on some signs, a coupler may be used instead to plug an RJ45 cable into the same location.)
- Do not separate the twisted pairs more than 0.5 inches from the termination point.

Table 1: Modular Network Adapter

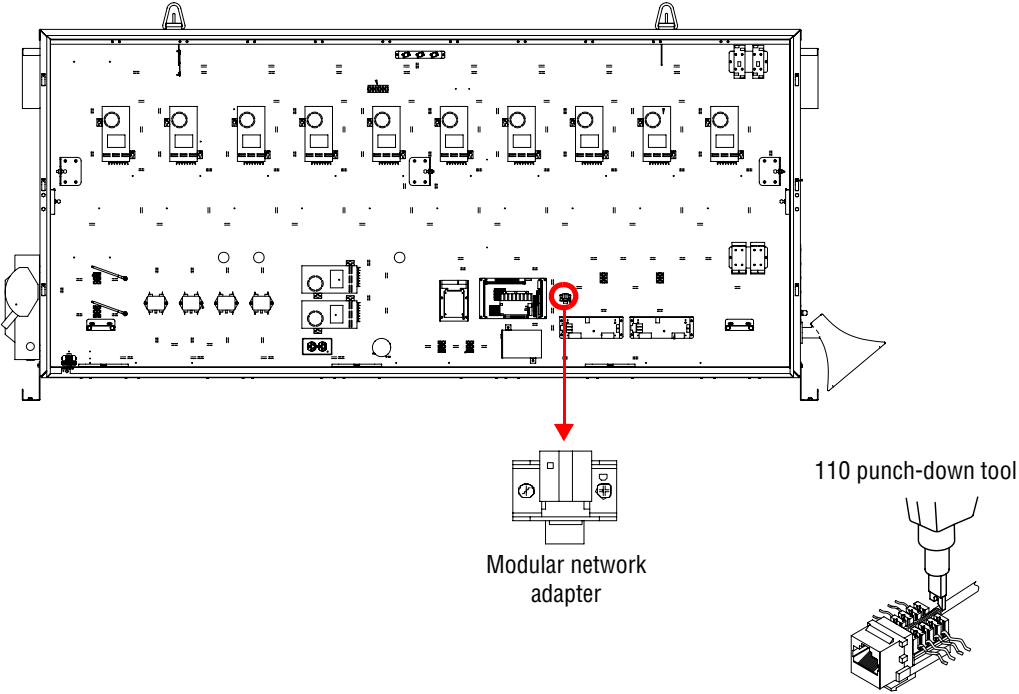

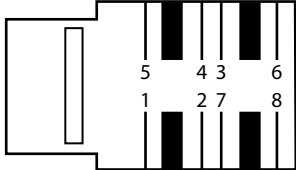
Category 5 T568A (8 wire)		Category 5 T568B (8 wire)		Position the wires into the channels on the modular network adapter as shown below.
110 type connector	RJ45 jack	110 type connector	RJ45 jack	
Wht/Blu	5	Wht/Blu	5	
Blu/Wht	4	Blu/Wht	4	
Wht/Org	3	Wht/Org	1	
Org/Wht	6	Org/Wht	2	
Wht/Grn	1	Wht/Grn	3	
Grn/Wht	2	Grn/Wht	6	
Wht/Brn	7	Wht/Brn	7	
Brn/Wht	8	Brn/Wht	8	

5. If applicable, connect the speakers to the sign's TuneBlaster sound card(s).
 - A sign may have up to 16 speakers. Each speaker should be 8 ohms and at least 10 watts.
 - For each speaker, insert one non-metallic, compression type connector into a speaker conduit.
 - Run speaker wire (Belden 8471 or equivalent) from each speaker through the connector to the sound card inside the sign.
 - Connect the wires to the TuneBlaster sound card using a #1 screwdriver (1/16" wide tip) to depress the spring clip and insert the speaker wire.

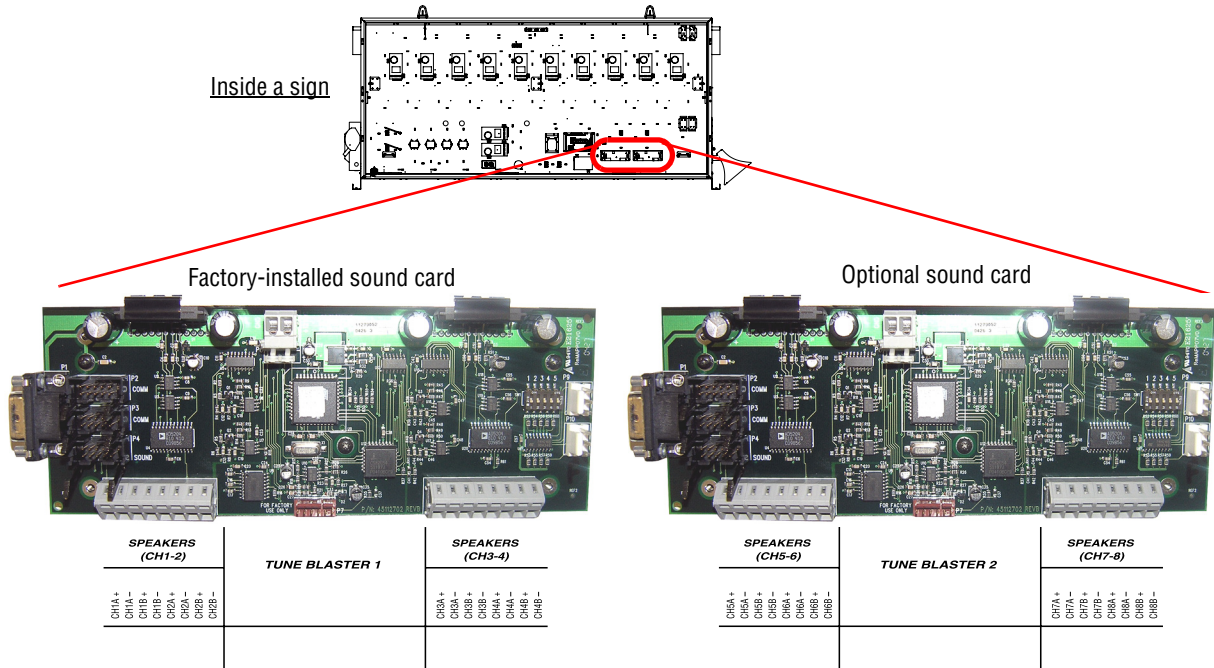

Each sign can support up to 16 speakers.
There are 8 channels with two speakers (A and B) per channel.

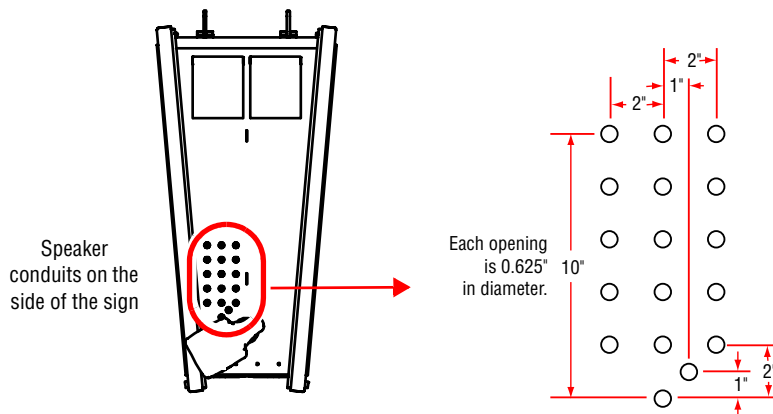

6. Connect power to the sign.

- Make sure that power is *not* applied at the power source.
- Run two 120VAC lines into the power conduit on the side of the sign with the disconnect box.
- Open the disconnect box.
- Connect the wires as shown below. Do not remove the yellow wires as they provide power to the fluorescent lighting circuit and service outlet. The fluorescent service light and service outlet are powered even when the disconnect box is open. The sign must be properly earth grounded.

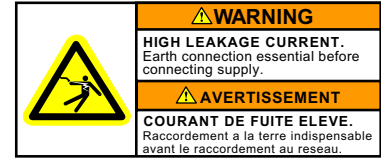

Yellow wires do *not* go through the circuit breaker. (They supply power to the sign's internal lights and service outlet.)

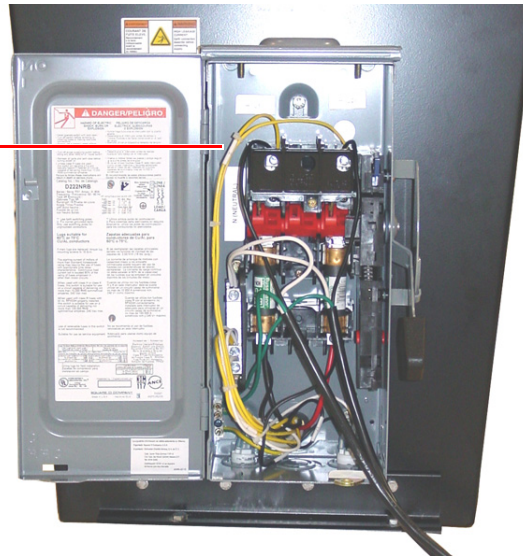

Temporary power wiring

Disconnect box wiring

- A two-pole disconnect device is installed on the sign. It allows the Master and Slave sides to be powered separately using two feeds. (Note that one feed can be wired and then the two poles jumpered together.)
- Incoming service should be 125% of maximum current drawn. See "Sign identification" on page 18 for the amperage of the sign. For additional information, refer to NEC guidelines.
- Close the disconnect box. Apply 120VAC power at the power source. Then move the switch on the disconnect box up to the ON position.
- 320 x 128 and 320 x 112 size signs uses 35A fuses. 320 x 96, 320 x 80, and 320 x 64 size signs use 30A fuses.

Troubleshooting

Major sign components

Table 2: Major sign components

Shown below is a 320x112 Master sign. Other sign sizes are similar.

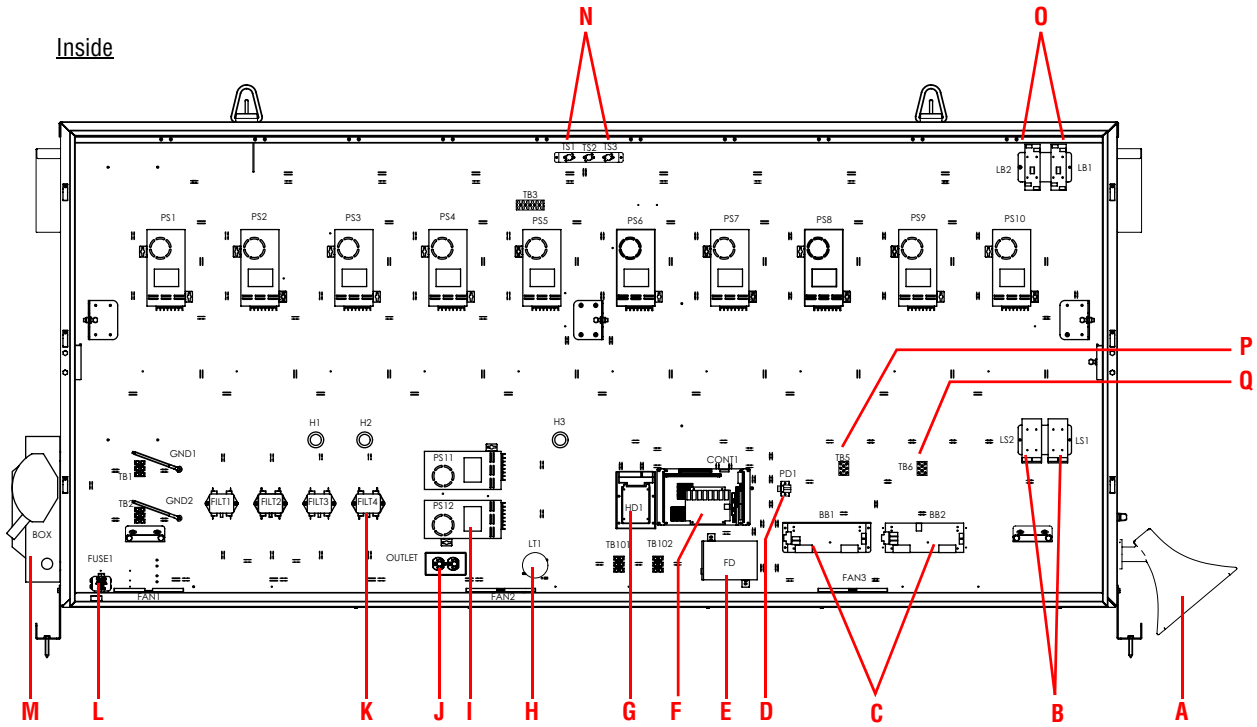

LED door underside

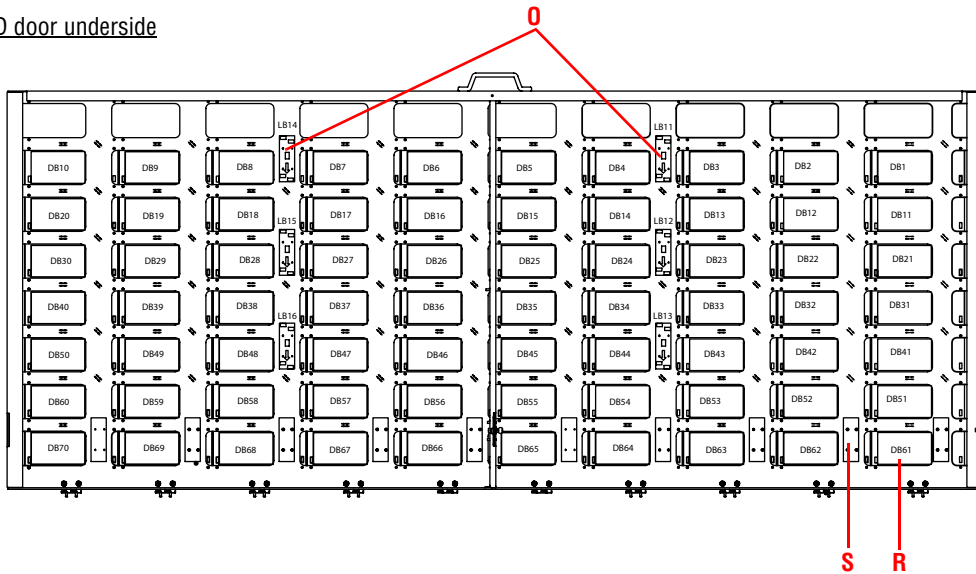

Item	Name	Description
A	Speaker (option)	Plays sounds from TuneBlaster sound board.

Table 2: Major sign components

B	Level Shifter board 	Changes 5V logic to 12V logic.
C	TuneBlaster sound board	Used to play sounds through up to 4 speakers per board. The TuneBlaster sound board is an option.
D	Modular network adapter 	Connects Ethernet adapter on the sign controller board to an external Ethernet network. A 110 punch-down tool is required to wire an external Ethernet connection to this adapter (see Table 1, "Modular Network Adapter," on page 8).
E	Floppy disk (may not be installed)	Used to load software.
F	Controller board with turbo adapter board (on top)	The turbo adapter board is an interface between the controller board and the LED driver boards. One of two controller boards will be used: <ul style="list-style-type: none"> • Arcom SBC-GX1 embedded PC board with Geode 300MHz processor. • Advantech PCM-9579 embedded PC board with Celeron 650MHz processor.
G	Hard disk drive (not installed on Windows CE units)	Used to store operating system and programs.
H	Light 	Philips 371237 18W compact fluorescent bulb. Powered through fuses (item L).
I	Power supply	Supplies either 5V (Meanwell SP-200-5) or 12V (Meanwell SP-200-12) power to sign components.
J	AC outlet (may not be installed)	Powered through fuses (item L), not through disconnect box.
K	EMI filter	Removes electromagnetic interference from incoming and outgoing AC power.
L	Fuses	Two, 1/4 x 1 1/4-inch, fast acting, 10A, 250V fuses used for items H and J.
M	Disconnect box	AC power switchbox.
N	Thermostats 	Control the following sign functions: <ul style="list-style-type: none"> • TS1 — At 120F, turns fans on. • TS2 — At 130F, dims the sign's LEDs. • TS3 — At 130F, turns sign off.
O	Loopback board 	Boosts signal strength.

Table 2: Major sign components

P	TB5 DC terminal block		5V and 12V wiring terminals.
Q	TB6 DC terminal block		
R	LED driver board		
S	Power distribution board	Supplies 5V and 12V to LED driver boards.	

Problem/Solution chart

#	Problem	Recommended solution
1	On one side of the sign, half of the display (3 rows of LED driver boards) is a solid color, displaying garbage, or blank	<ol style="list-style-type: none"> 1. Swap the cables on the Turbo board. <ul style="list-style-type: none"> • If the problem is on the sign's Master side, swap P1 and P2. • If the problem is on the sign's Slave side, swap P5 and P6. If the problem goes to the other half of the display, then the Turbo board is bad. 2. Swap the cables P1 and P2 on the Level Shifter board located on the bad side of the display. If the problem goes to the other half of the display, then the cable between the Turbo board and the Level Shifter board is bad. 3. Swap the cables P3 and P4 on the Level Shifter board located on the bad side of the display. If the problem goes to the other half of the display, then the Level Shifter board is bad. 4. Swap the cables P3 and P1 on the Loopback board located on the bad side of the display. If the problem goes to the other half of the display, then the cable between the Level Shifter board and the Loopback board is bad. 5. Swap the cables P4 and P2 on the Loopback board located on the bad side of the display. If the problem goes to the other half of the display, then the Loopback board is bad. 6. Swap the cables going from the Loopback board to the LED driver board at the LED driver board located on the bad side of the display. If the problem goes to the other half of the display, then the cable between the Loopback board and the LED driver board is bad.
2	On one side of the sign, half of the display (3 rows of LED driver boards) is blank.	<ol style="list-style-type: none"> 1. Check the cable connections on the Turbo board. <ul style="list-style-type: none"> • The Master side must be plugged into P1 and P2. • The Slave side must be plugged into P5 and P6. 2. Check the power going to the first LED driver board in the chain to make sure it is getting both 5V and 12V. 3. Run through the steps for problem #1 above.
3	On one side of the sign, part of the display is displaying garbage.	<ol style="list-style-type: none"> 1. Run through the steps for problem #1 above. 2. If the problem is not resolved, then check the terminal strips for loose wires.
4	One side of the sign is blank.	<ol style="list-style-type: none"> 1. Check the cable connections on the Turbo board. <ul style="list-style-type: none"> • The Master side must be plugged into P1 and P2. • The Slave side must be plugged into P5 and P6. 2. On the Turbo Card, swap P1 and P2 with P5 and P6. If the problem moves to the other side of the display, then the Turbo board is bad. 3. Check the 12V power supply and all of the 5v power supplies to make sure they are outputting the correct voltage. 4. Check the power going to the first LED driver board in the chain to make sure it is getting both 5V and 12V.

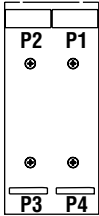
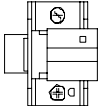
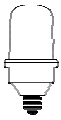
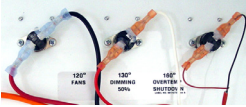
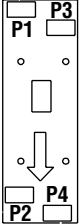
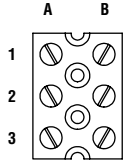
#	Problem	Recommended solution
5	The entire sign is blank.	<ol style="list-style-type: none"> 1. Is it powered on? 2. Check the cable connections on the Turbo board. <ul style="list-style-type: none"> • The Master side must be plugged into P1 and P2. • The Slave side must be plugged into P5 and P6. 3. On the Turbo board, check the status LEDs: <ul style="list-style-type: none"> • D1 – Power • D3 – FPGA is loaded <p>If D1 is on, but D3 is not, then there could be a fault with the controller board, Turbo board, or the hard drive.</p> 4. Is the Controller's PWR LED on? 5. Do they still have communication to the display? 6. Call Adaptive Tech Support.
6	On one side of the sign, the top half of the display is showing the data for the bottom half of the display, and the bottom half of the display is showing the data for the top half of the display.	<p>Swap the cables on the Turbo board:</p> <ul style="list-style-type: none"> • P1 and P2 if the problem is on the Master side. • P5 and P6 if the problem is on the Slave side.
7	A diagonal test pattern in a red, green, and amber sequence is running.	<p>Hard drive is not functioning properly:</p> <ol style="list-style-type: none"> 1. Check to make sure the hard drive IDE cable is connected to the controller board. 2. Check to make sure the voltage at the hard drive is 5 volts.
8	Display is cycling between diagonal lines, solid vertical columns, and the Ethernet information.	<p>The Test Mode DIP Switch on the TuneBlaster board is set to ON. Switch DIP Switch #5 on the TuneBlaster board to OFF.</p>
9	A column of LEDs is out on one LED driver board.	<p>Replace the LED cube on the driver board that has the failure. If the problem persists, replace the entire LED driver board.</p>
10	A row of LEDs is out on one LED driver board.	<p>Replace the entire LED driver board.</p>
11	There is a single LED out on one cube of an LED driver board.	<p>Replace the cube containing the LED that is out.</p>
12	There is a <i>ghosting column</i> of LEDs (a column of LEDs that is dimly on when it is supposed to be off).	<p>Replace the cube that has the failure on it. If the problem persists, replace the entire LED driver board.</p>
13	There is a <i>shorted column</i> of LEDs (a column of LEDs that is on in addition to the column that is supposed to be on).	<p>Replace the cube that has the failure on it. If the problem persists, replace the entire LED driver board.</p>
14	There is a <i>shorted row</i> of LEDs (a row of LEDs that is on in addition to the row that is supposed to be on).	<p>Replace the cube that has the failure on it. If the problem still persists, replace the entire LED driver board.</p>
15	An entire LED driver board is blank, but there is data on the drivers on both sides of the blank board.	<p>Check the power going to the LED driver board. It may not be getting the 5 volts it needs. However, if the power is good, then replace the LED driver board.</p>

#	Problem	Recommended solution
16	An entire LED driver board is blank and there is no data on the rest of the LED driver boards in the chain.	<ol style="list-style-type: none"> 1. Use a long data cable to bypass the first blank LED driver board. If the data comes back on, then the bypassed LED driver board has a bad input. Replace the bypassed LED driver board. 2. If #1 doesn't fix the problem, then use a long data cable to bypass the LED driver board to the right of the first blank LED driver board. If the data comes back on, then the bypassed LED driver board has a bad output. Replace the bypassed LED driver board.
17	An entire LED driver board is dimly lit green. However, the rest of the LED driver boards in the chain are lit dimly green.	The data cable going into the first dimly lit green LED driver board was installed backwards.
18	No network communication (only applies to Arcom embedded PC controller).	<ol style="list-style-type: none"> 1. Open a Command Prompt. 2. Type "IPCONFIG". 3. If the returned result is 'No Interfaces Present', the BIOS reverted back to the factory default. 4. When the AVPC is powering up, press DELETE to get into the BIOS. 5. Use the arrow keys to move to <i>PNP/PCI CONFIGURATION</i>. Then press ENTER. 6. Use the arrow keys to move to <i>Resources Controlled By</i>. Verify that it is set to <i>Auto</i>. 7. Press Page Down to change the value to <i>Manual</i>. Verify that all are set to <i>PCI/ISA PnP</i>. 8. Use the arrow keys to move to <i>IRQ-5 assigned to</i>: Then press Page Down to change the value to <i>Legacy ISA</i>. 9. Use the arrow keys to move to <i>IRQ-10 assigned to</i>: Then press Page Down to change the value to <i>Legacy ISA</i>. 10. Use the arrow keys to move to <i>IRQ-11 assigned to</i>: Then press Page Down to change the value to <i>Legacy ISA</i>. 11. Press ESC to return to the main menu. 12. Use the arrow keys to move to <i>SAVE & EXIT SETUP</i>. Then press ENTER. 13. At the <i>SAVE to CMOS and EXIT</i> prompt, press Y. Then press ENTER. <p>If the returned result displays the configured IP Address, check network cables and connections.</p>

#	Problem	Recommended solution
19	No sound from sound card (TuneBlaster sound boards).	<ol style="list-style-type: none"> 1. Check cable connections between the controller board and the TuneBlaster board(s). 2. Check the speaker wiring to the TuneBlaster board(s). 3. Are the TuneBlaster board(s) getting the required 12 volts? 4. (Only applies to Arcom embedded PC controller.) Open a Command Prompt. Type <i>IPCONFIG</i>. If the returned result is <i>No Interfaces Present</i>, then the BIOS reverted back to the factory default. In this case, do the following: <ul style="list-style-type: none"> • When the AVPC is powering up, press DELETE to get into the BIOS. • Use the arrow keys to move to <i>PNP/PCI CONFIGURATION</i>. Then press ENTER. • Use the arrow keys to move to <i>Resources Controlled By</i>: Verify that it is set to <i>Auto</i>. • Press Page Down to change the value to <i>Manual</i>. Verify that all are set to <i>PCI/ISA PnP</i>. • Use the arrow keys to move to <i>IRQ-5 assigned to</i>: Then press Page Down to change the value to <i>Legacy ISA</i>. • Use the arrow keys to move to <i>IRQ-10 assigned to</i>: Then press Page Down to change the value to <i>Legacy ISA</i>. • Use the arrow keys to move to <i>IRQ-11 assigned to</i>: Then press Page Down to change the value to <i>Legacy ISA</i>. • Press ESC to return to the main menu. • Use the arrow keys to move to <i>SAVE & EXIT SETUP</i>. Then press ENTER. • At the <i>SAVE to CMOS and EXIT</i> prompt, press Y and then press ENTER. <p>If the returned result displays the configured IP Address, the BIOS is okay.</p> <ol style="list-style-type: none"> 5. Cycle power on the display. Does the sound card play its power-up tune? 6. If 1, 2, 3, and 4 are good, and 5 doesn't play a tune, then replace the sound card.

Appendix

Sign identification

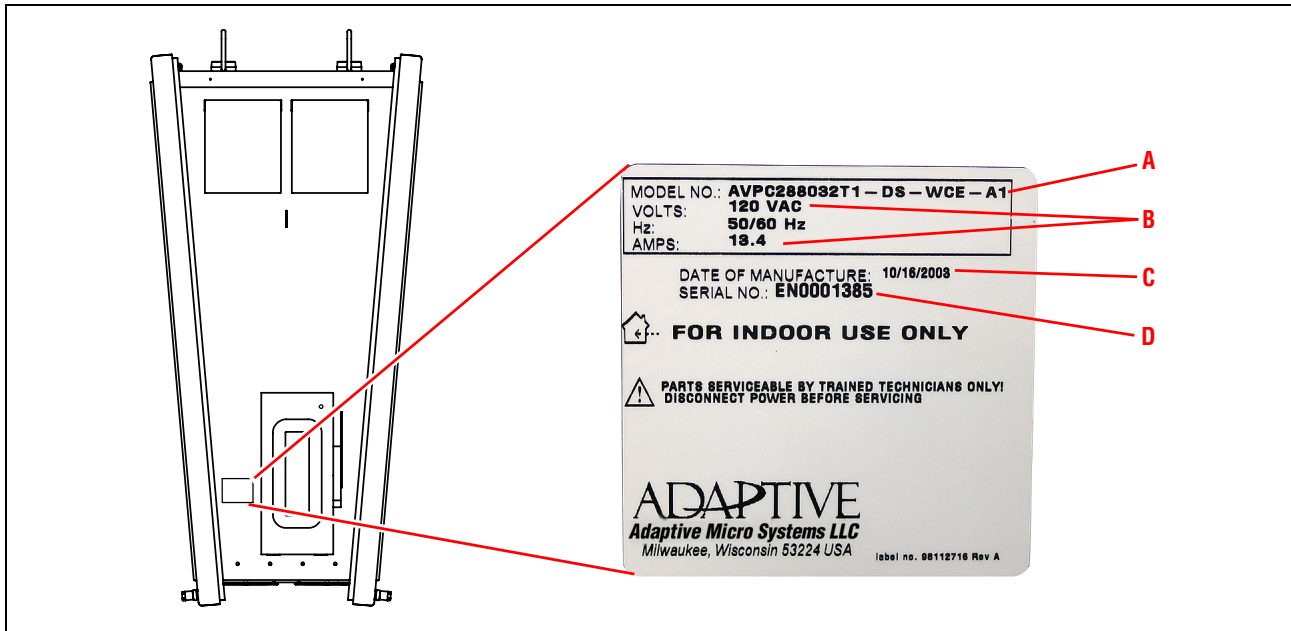

Item	Name	Model number description
A	Model number	<p><u>AVPC320096T1 - DS - W2K - A4</u></p> <ul style="list-style-type: none"> — <u>Music channels:</u> A1 = 1 music channel (up to 2 speakers) A4 = 4 music channels (up to 8 speakers) A8 = 8 music channels (up to 16 channels) — <u>Sign operating system:</u> W2K = Windows 2000 WCE = Windows CE — <u>Sign type:</u> DS = double-sided SS = single-sided — <u>Model type</u> — <u>Sign display width and height (in pixels)</u> 320128 = 320 x 128 320112 = 320 x 112 320096 = 320 x 96 320080 = 320 x 80 320064 = 320 x 64 — <u>Sign model:</u> AVPC = AlphaVision PC
B	Electrical information	Input voltage, frequency, and amperage.
C	Date of manufacture	Month, day, and year the sign was made.
D	Serial number	Consecutive, unique identification number.

Sign technical specifications

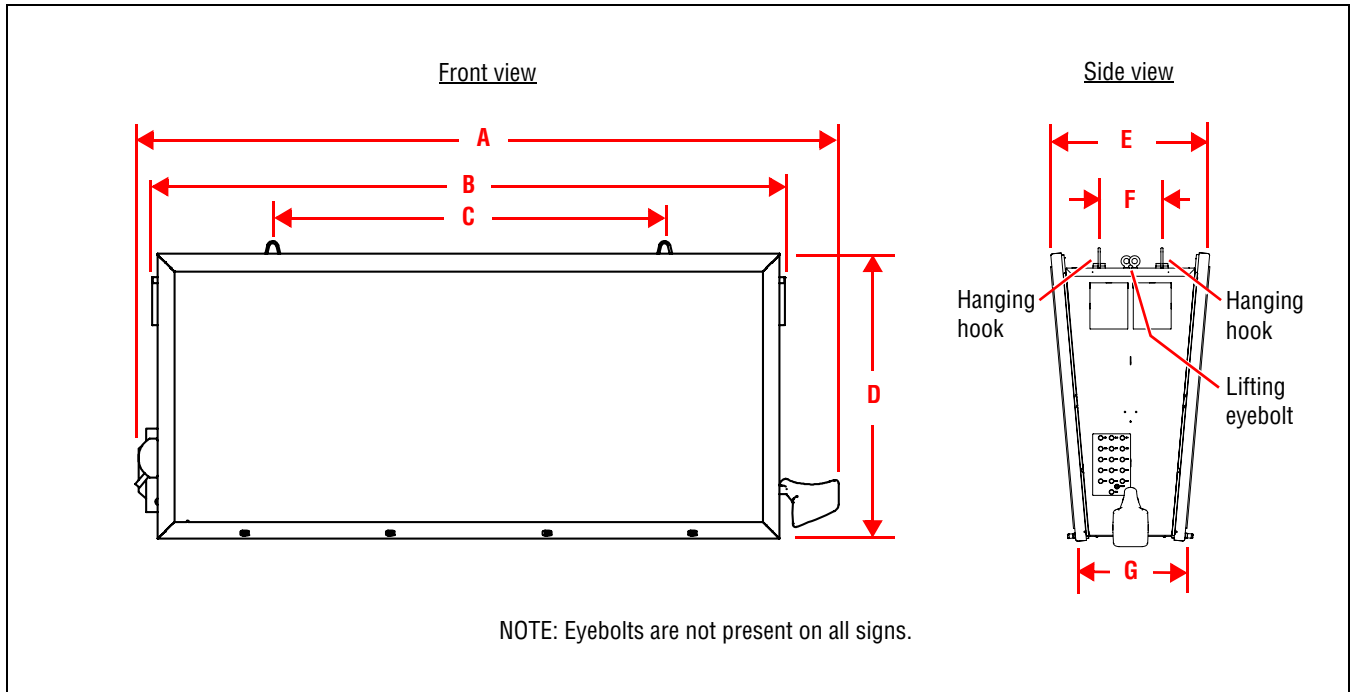

Sign size (LxH in pixels)	Double- sided sign weight (pounds, approx)	Dimensions (inches)							Input current			
		A	B	C	D	E	F	G	Type	Total (A)	Master sign (A)	Slave sign (A)
320 x 128	1000	125.59	112.91	70.00	53.2	25.37	11.4	17.00	Rated maximum	51.0	26.7	24.3
									Maximum operation	33.2	17.4	15.8
									Typical operation	12.8	6.7	6.1
320 x 112	940	125.59	112.91	70.00	53.2	25.37	11.4	17.00	Rated maximum	45.4	23.9	21.5
									Maximum operation	29.5	15.5	14.0
									Typical operation	11.4	6.0	5.4
320 x 96	870	125.83	112.91	70.00	43.7	24.93	11.4	17.00	Rated maximum	40.0	21.2	18.8
									Maximum operation	26.0	13.8	12.2
									Typical operation	10.0	5.3	4.7
320 x 80	750	125.83	112.91	70.00	43.7	24.93	11.4	17.00	Rated maximum	34.4	18.4	16.0
									Maximum operation	22.4	12.0	10.4
									Typical operation	8.6	4.6	4.0
320 x 64	650	125.83	112.91	70.00	34.1	22.2	11.4	17.00	Rated maximum	28.8	15.6	13.2
									Maximum operation	18.8	10.1	8.7
									Typical operation	7.2	3.9	3.3

Lifting eyebolt and hanging hook dimensions

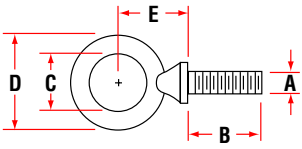

Sign size (LxH in pixels)	Dimensions (inches)				
	A	B	C	D	E
320 x 128	0.50	1.50	1.19	2.06	1.41
320 x 112					
320 x 96					
320 x 80					
320 x 64					

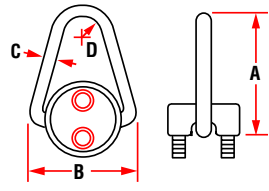

Sign size (LxH in pixels)	Dimensions (inches)			
	A	B	C	D
320 x 128	3.80	3.19	0.38	0.63
320 x 112				
320 x 96				
320 x 80				
320 x 64				

Controller board jumpers and connectors

Advantech PCM-9579 Celeron 650MHz controller board

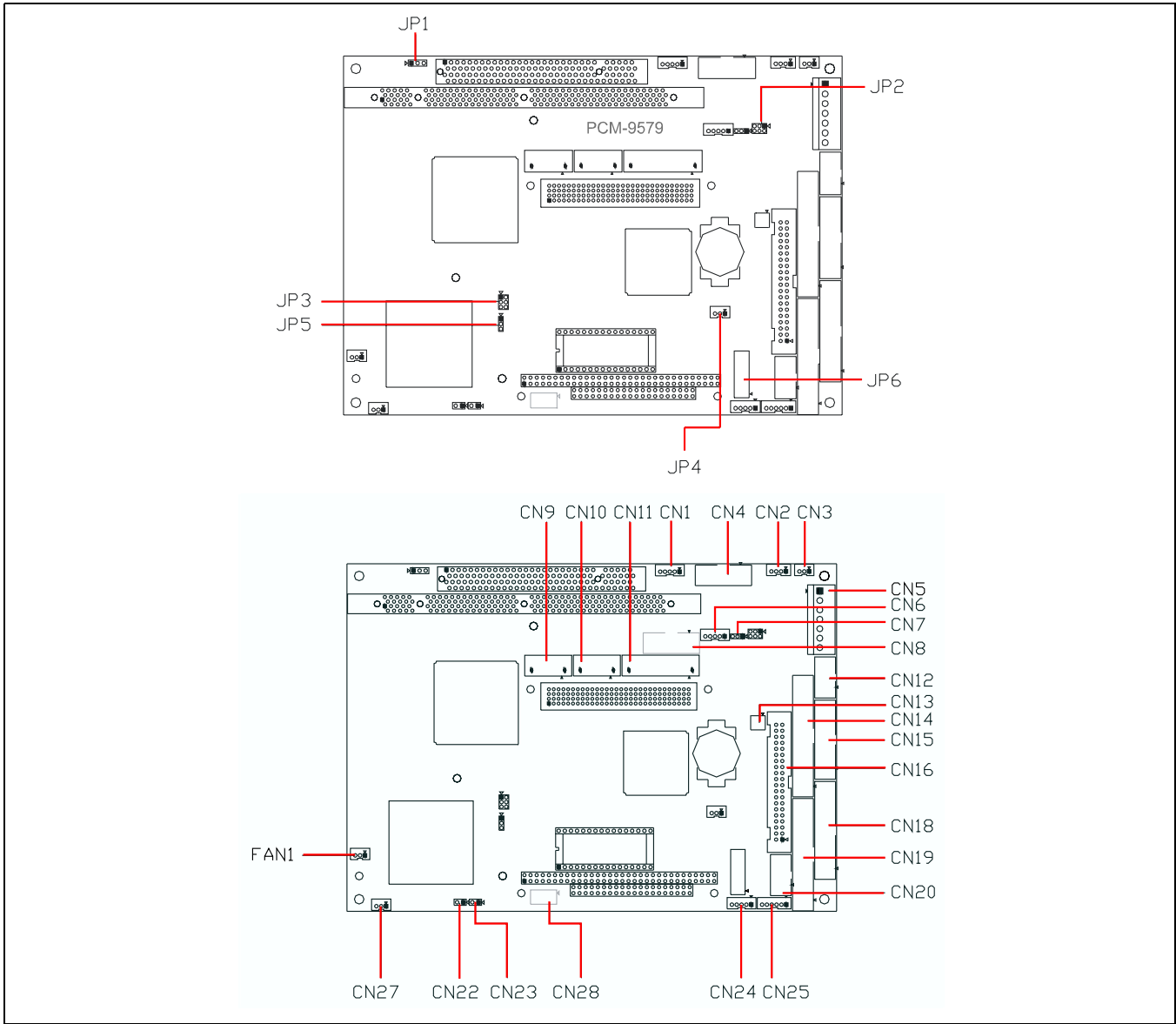

Item	Name	Description
JP1	PCI VIO select	
JP2	LAN controller power select (Rev A101 only)	Supports Wake-On-LAN (JP6 has to set to Standby 3.3V position).
JP3	DOC2000 address select	
JP4	CMOS clear	<p>This jumper is used to erase CMOS data and reset system BIOS information. This is the procedure for clearing CMOS:</p> <ol style="list-style-type: none"> 1. Remove power from the controller board. 2. Short pin 2 and pin 3. 3. Return jumper to pins 1 and 2. 4. Apply power to the controller board. The BIOS should now reset to its default setting.

JP5	Watchdog timer action	When the watchdog timer activates (CPU processing has come to a halt), the timer can either reset the system (short pins 1 and 2) or generate an interrupt on IRQ11 (short pins 2 and 3).
JP6	COM2 RS232/422/485 setting	Used to set how the CN19 COM2 serial port is used: RS232, RS422, or RS485.
CN1	TV-out connector	Support composite video and S-video output in either NTSC or PAL format.
CN2	Audio CD in connector	Inputs CD audio signals into the audio controller.
CN3	ATX feature connector	The controller can support an advanced soft power switch function if an ATX power supply is used.
CN4	Audio connector	On a 16-pin flat-cable connector provides all major audio signals: Microphone in (mono), Line in (stereo), Line out (stereo), and Speaker out (stereo).
CN5	EBX main power connector	Supplies main power to the controller board (+5V) and to devices that require +12V.
CN6	Backlight control connector	
CN8	CRT display connector	
CN9	LVDS LCD panel connector	
CN10	Extension flat panel connector	
CN11	Flat panel connector	Can connect up to 24-bit TFT LCD.
CN12	Ethernet connector	10/100 BASE-T connector compliant with IEEE 802.3U 10/100Mbps CSMA/CD standards.
CN13	Power and HDD LED connector	The HDD LED indicator for hard disk drive access is an active low signal (24mA sink rate).
CN14	IDE hard drive connector (secondary)	See CN16.
CN15	Parallel port connector	Multi-mode (ECP/EPP/SPP) parallel port accessed via a 26-pin flat-cable connector. The parallel port is designated as LPT1. The parallel port interrupt channel is set to IRQ7.
CN16	IDE hard drive connector (primary)	Using the two IDE channels, up to four Enhanced Integrated Devices Electronics hard disk drives or CDROMs can be connected. The primary channel (CN16) support faster data transfer, PID mode 3, mode 4, and UDMA.100. The secondary channel (CN14) only supports UDMA/33.
CN17	PC/104 plus (ISA+PCI) expansion	
CN18	Floppy drive connector	Up to two floppy disk drives can be connected. However, a 34-pin daisy-chain drive connector is required for a dual-drive system.
CN19	COM port connector	Supports four serial ports: COM1, 3, 4 (RS232) and COM2 (RS232/422/485). Use JP6 to configure COM2.
CN20	USB channel 1, 2 connector	
CN21	n/a	
CN22	Reset button connector	If a reset switch is installed, it should be an open single-pole switch. Momentarily pressing the switch will activate a reset. The switch should be rated for 10mA, 5V.
CN23	ATX power on/off switch connector	
CN24	IR connector	Supports the optional wireless infrared transmitting and receiving module.
CN25	Keyboard and PS/2 mouse connector	
CN26	CompactFlash card connector	
CN27	Peripheral power connector	Supplies secondary power to devices that require -5V and -12V.
CN28	USB channel 3, 4 connector (optional)	

Arcom SBC-GX1 Geode 300MHz controller board

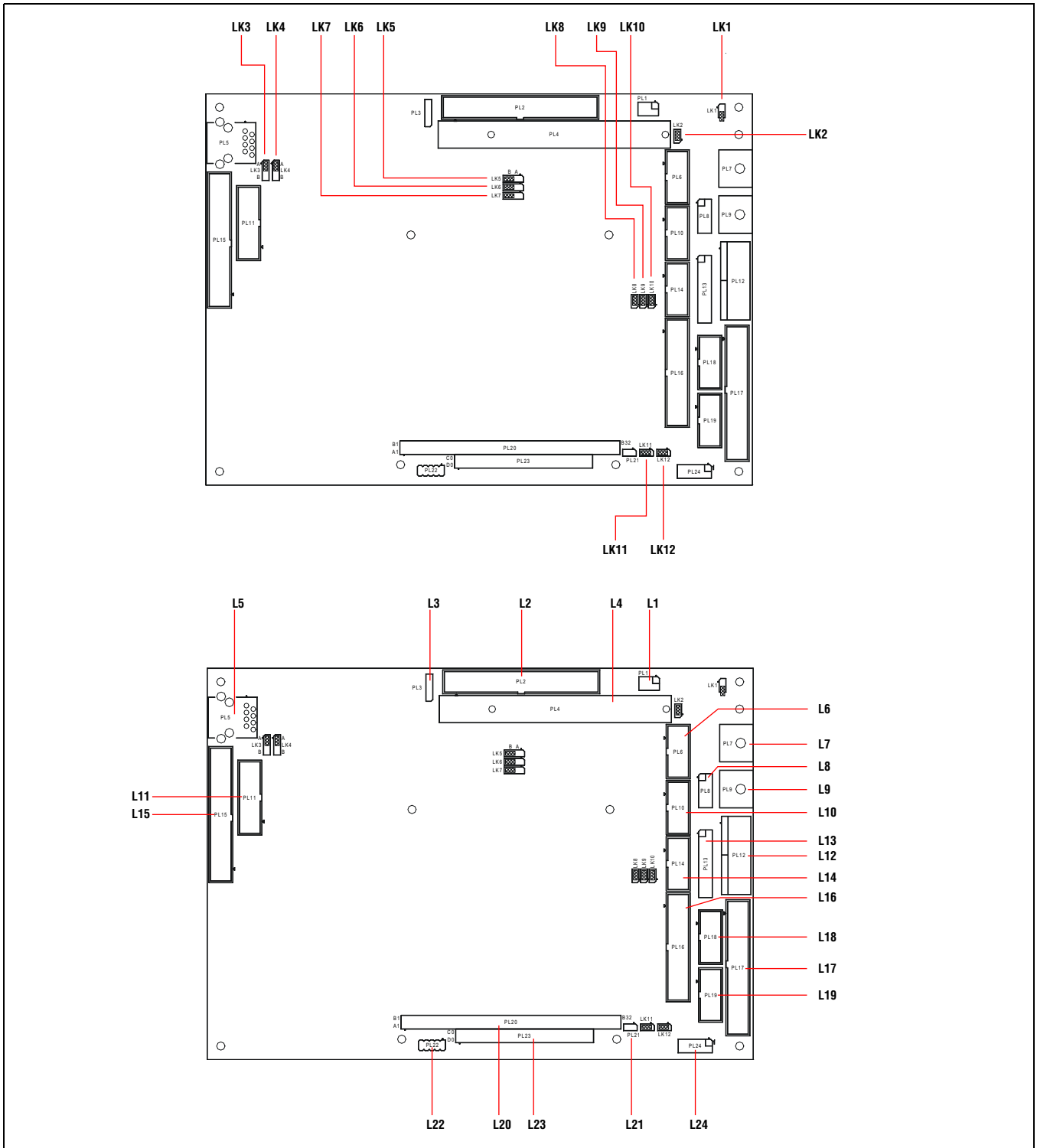

Item	Name	Description
LK1	Watchdog timer timeout selection	<ul style="list-style-type: none"> • Jumper on = 2-second timeout. • Jumper off = 8-second timeout (default).
LK2	Watchdog timer enable	When enabled, the watchdog timer can be started by writing to I/O location 93H: <ul style="list-style-type: none"> • Jumper on = enabled. • Jumper off = disabled (default).

LK3	LCD backlight voltage	Used to select the LCD backlight supply voltage (BLKSAFE): <ul style="list-style-type: none"> • Jumper on A = +5V backlight (default). • Jumper on B = +12V backlight. If +12V is selected, this voltage must be supplied from an external source via the power connector PL12 pin 4.
LK4	LCD panel power supply voltage	Used to select the LCD panel power supply voltage (VDDSAFE): <ul style="list-style-type: none"> • Jumper on A = +5V supply (default). • Jumper on B = 3.3V supply.
LK5	COM4 IRQ routing	Used to select which IRQ signal is connected to the COM4 serial port: <ul style="list-style-type: none"> • Jumper on A = IRQ3. • Jumper on B = IRQ10 (default).
LK6	COM3 IRQ routing	Used to select which IRQ signal is connected to the COM3 serial port: <ul style="list-style-type: none"> • Jumper on A = IRQ4. • Jumper on B = IRQ11 (default).
LK7	Clear CMOS/battery disable	A battery jumper is fitted that is used to prevent battery drain on the battery during shipment. This jumper can also be used to clear the contents of CMOS RAM: <ul style="list-style-type: none"> • Jumper on A = battery backup enabled. • Jumper on B = battery backup disabled. CMOS RAM cleared (default).
LK8	RS485/422 configuration	<ul style="list-style-type: none"> • Jumper on = RS485 receiver enabled (default). • Jumper off = RS485 receiver disabled.
LK9		<ul style="list-style-type: none"> • Jumper on = RS485 termination resistor connected (default). • Jumper off = RS485 termination resistor disconnected.
LK10		<ul style="list-style-type: none"> • Jumper on = RS422 termination resistor connected (default). • Jumper off = RS422 termination resistor disconnected.
LK11	User jumpers	<ul style="list-style-type: none"> • Jumper on = Bit 1 of 259H set to logic 1 (default). • Jumper off = Bit 1 of 259H set to logic 0.
LK12		<ul style="list-style-type: none"> • Jumper on = Bit 2 of 259H set to logic 1 (default). • Jumper off = Bit 2 of 259H set to logic 0.
PL1	Auxiliary functions	6-way 0.1-inch dual row pin header.
PL2	IDE interface	Up to two IDE hard disk drives can be supported by the SBC-GX1. Both drives should be connected to PL2 via a 40 way 1:1 ribbon cable. The primary drive should be setup as a "master" and the secondary drive as a "slave". The BIOS automatically detects the hard disk drive during the POST processes and configures the hardware correctly. The BIOS attempts to load an operating system from the primary disk drive which becomes drive C: once the operating system has loaded. If the board is fitted with flash memory and this has been formatted as a silicon disk drive, then it will be allocated drive D:. The secondary drive will be allocated the next available drive letter.
PL3	Ethernet controller status LEDs	Provides outputs that can be used to control LEDs for 10Mb, 100Mb, and LINK status.
PL4	PCI interface	32-bit card edge connector.
PL5	Ethernet interface	10/100baseTx via RJ45 connector.
PL6	COM3 RS232 serial port	
PL7	PS/2 keyboard	
PL8	USB serial port	Supports two USB sockets.
PL9	PS/2 mouse	
PL10	COM4 RS232 serial port	
PL11	VGA CRT interface	
PL12	EBX power supply connector	
PL13	General purpose I/O	
PL14	COM4 RS422/485 serial port	

PL15	VGA flat panel interface	
PL16	Parallel port interface	Supports a Centronics-compatible printer or ECP/EPP bi-directional device.
PL17	Floppy disk interface	
PL18	COM2 RS232 serial port	
PL19	COM1 RS232 serial port	
PL20	64-way PC/104 expansion	Supports 8/16-bit ISA bus style peripherals.
PL21	Flash access LED	
PL22	In-system-program header	
PL23	40-way PC/104 expansion	Supports 16-bit ISA bus style peripherals.
PL24	Audio functions	
PL25	CompactFlash socket (underside of board)	

Installing a second TuneBlaster sound card

NOTE: This option is not available for all signs.

1. Remove power from the sign.



2. Open *both* sides of the sign.



3. Locate the factory-installed TuneBlaster sound card:

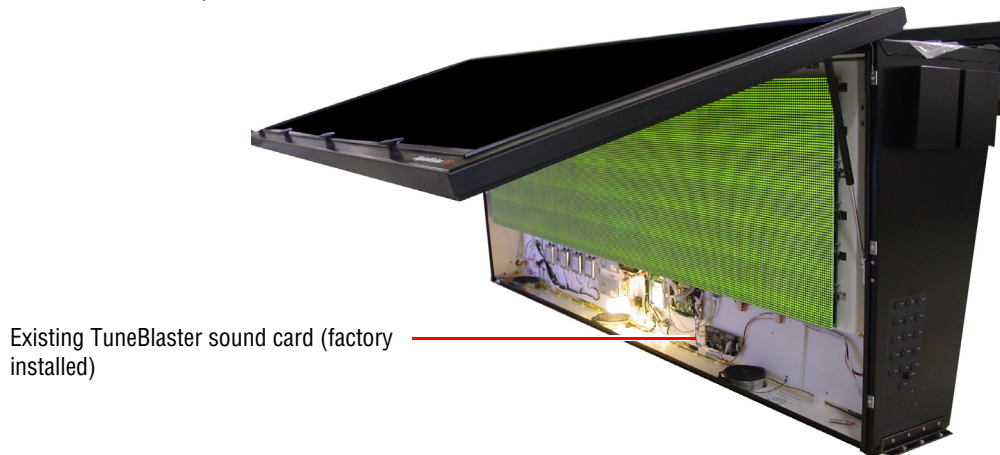

- To the right of the factory-installed TuneBlaster sound card, locate the four (4) mounting holes.

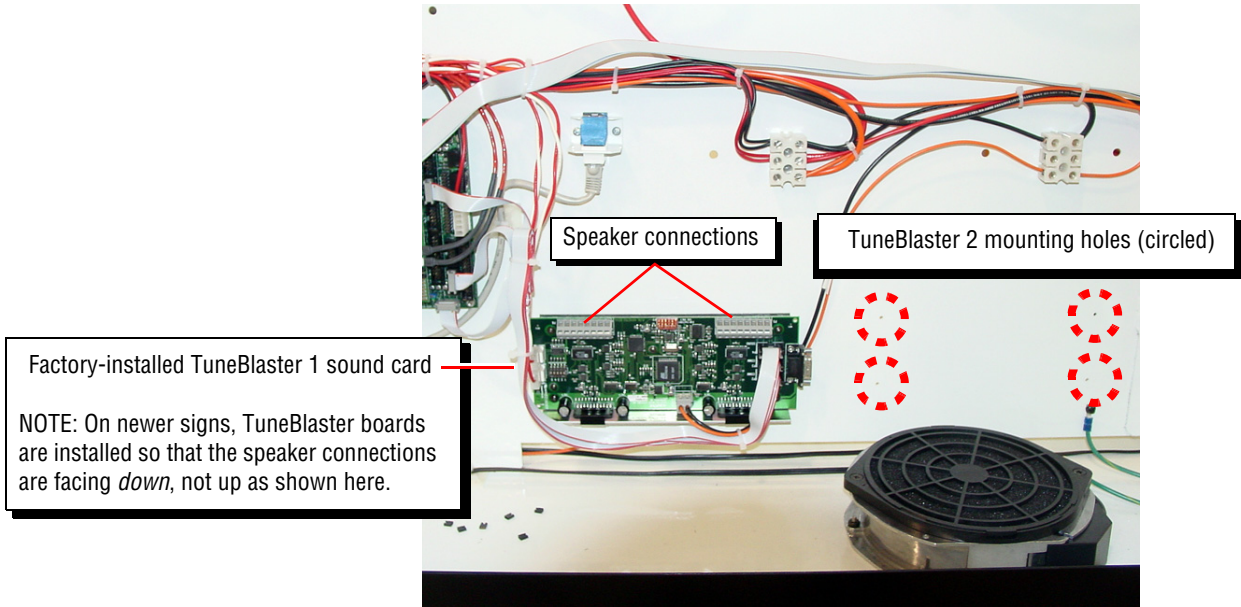

- Fasten the second TuneBlaster sound card to the sign using the four (4) mounting holes:

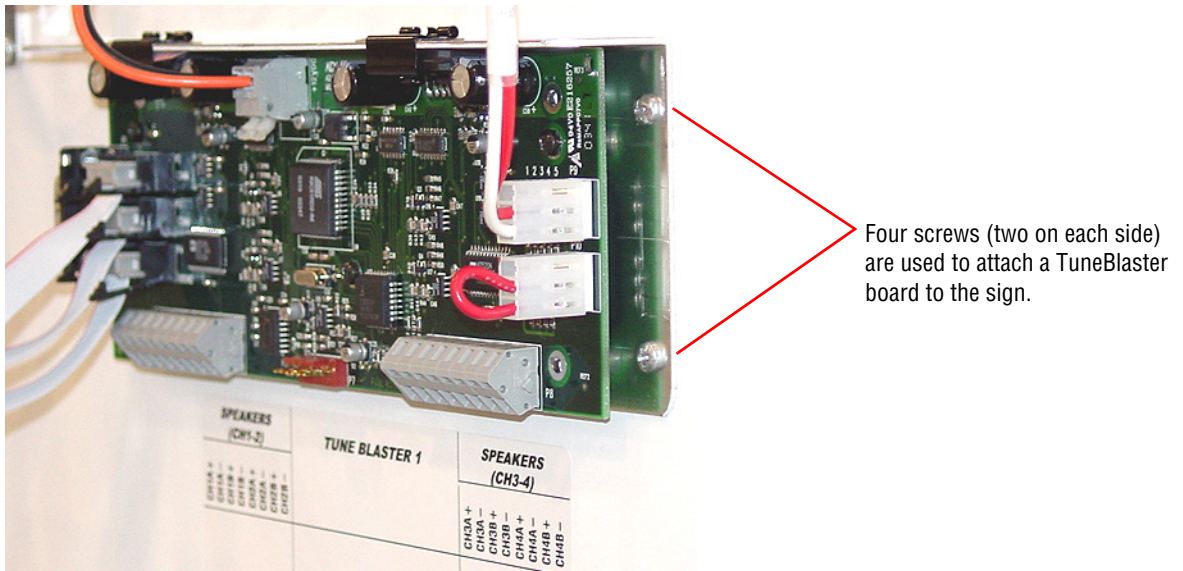

- Connect the second TuneBlaster sound card. See "Wiring diagrams" on page 28.

Wiring diagrams

Advantech PCM-9579 650MHz controller board wiring diagrams:

- 320x128 sign (page 30)
- 320x112 sign (page 32)
- 320x96 sign (page 34)
- 320x80 sign (page 36)
- 320x64 sign (page 38)

Arcom SBC-GX1 300MHz controller board wiring diagrams:

- 320x128 sign (page 40)
- 320x112 sign (page 42)
- 320x96 sign (page 44)
- 320x80 sign (page 46)
- 320x64 sign (page 48)

THIS PAGE INTENTIONALLY LEFT BLANK.

Advantech PCM-9579 controller board wiring for 320x128 sign

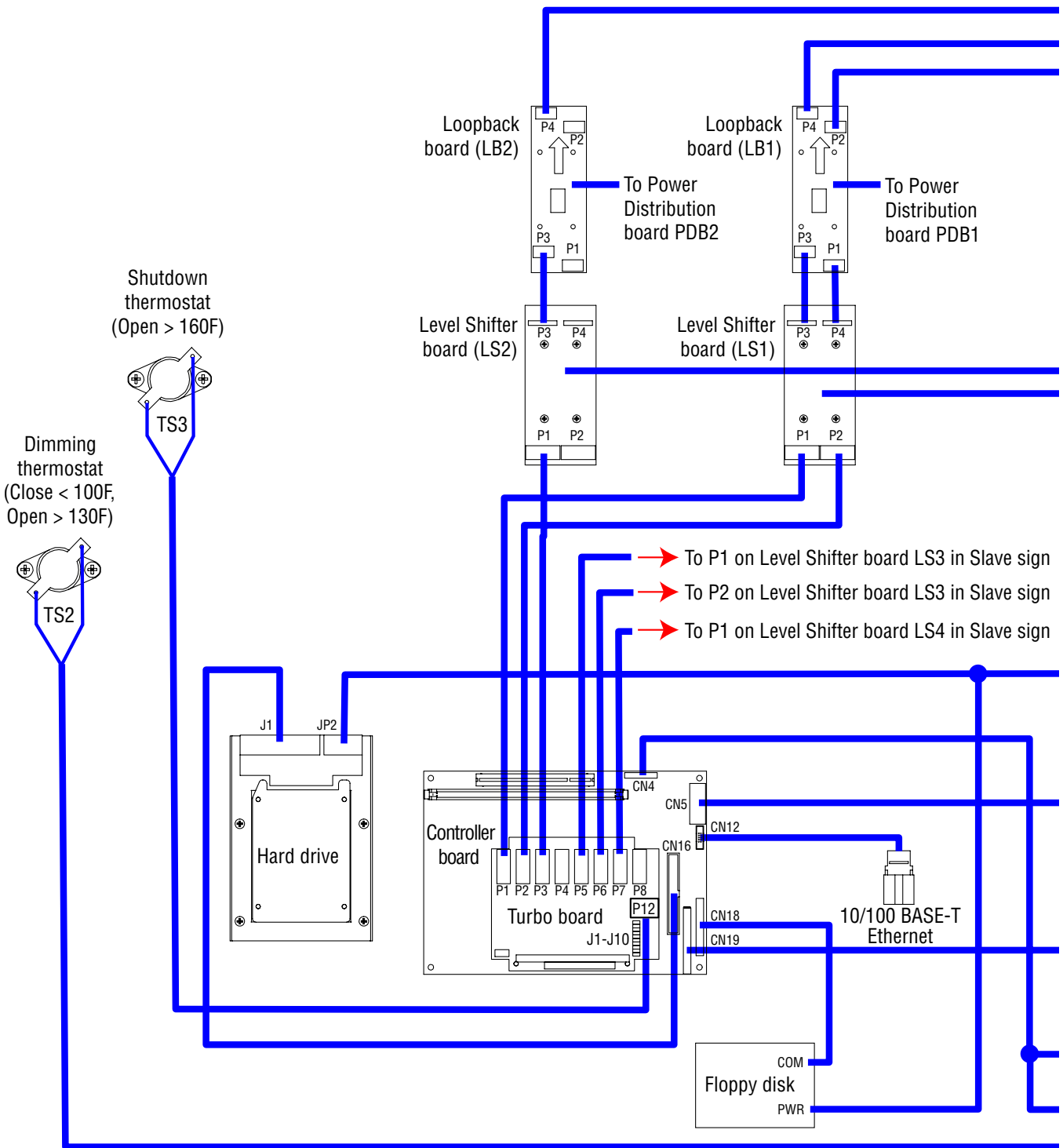

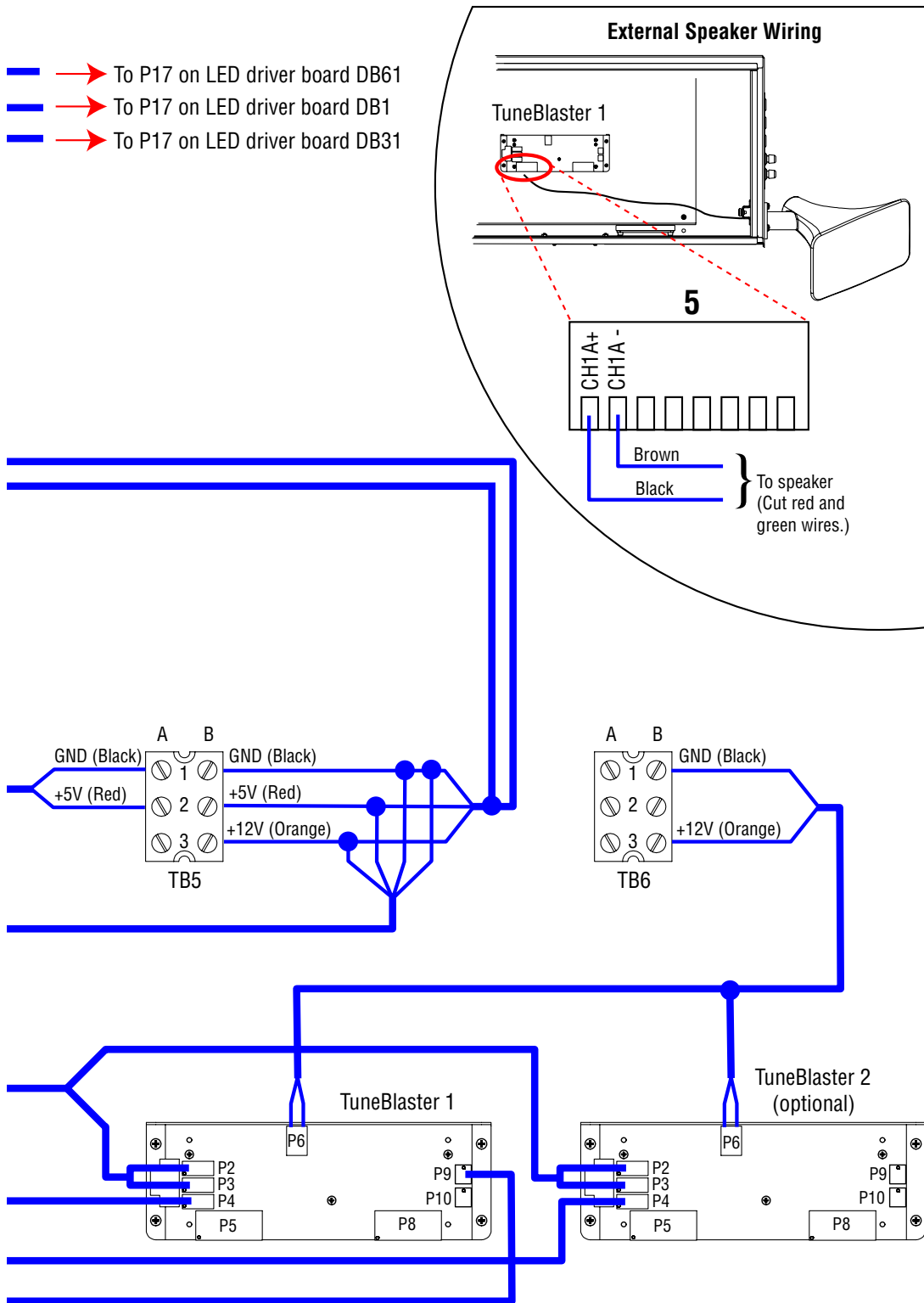

Advantech PCM-9579 controller board wiring for 320x112 sign

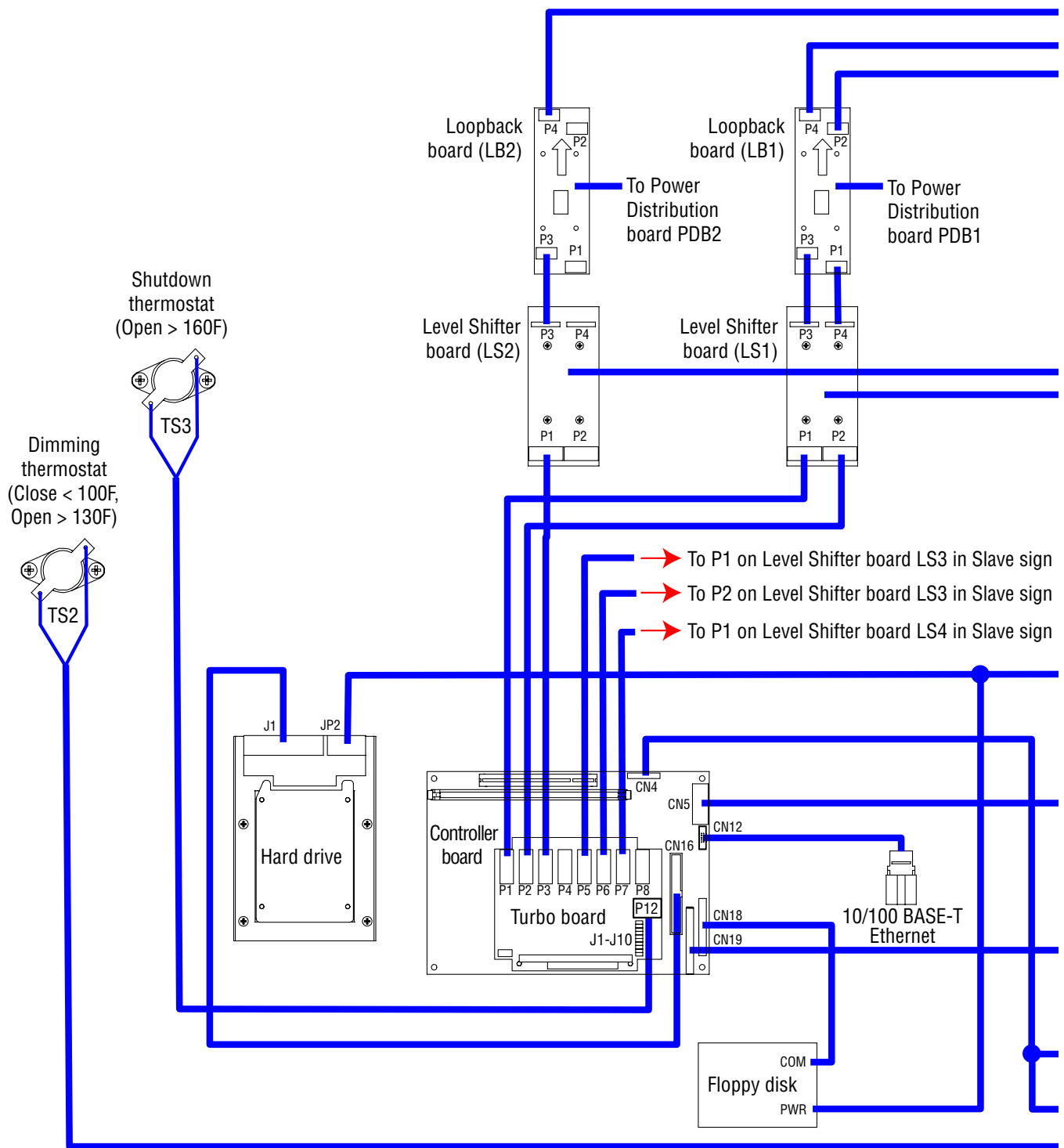

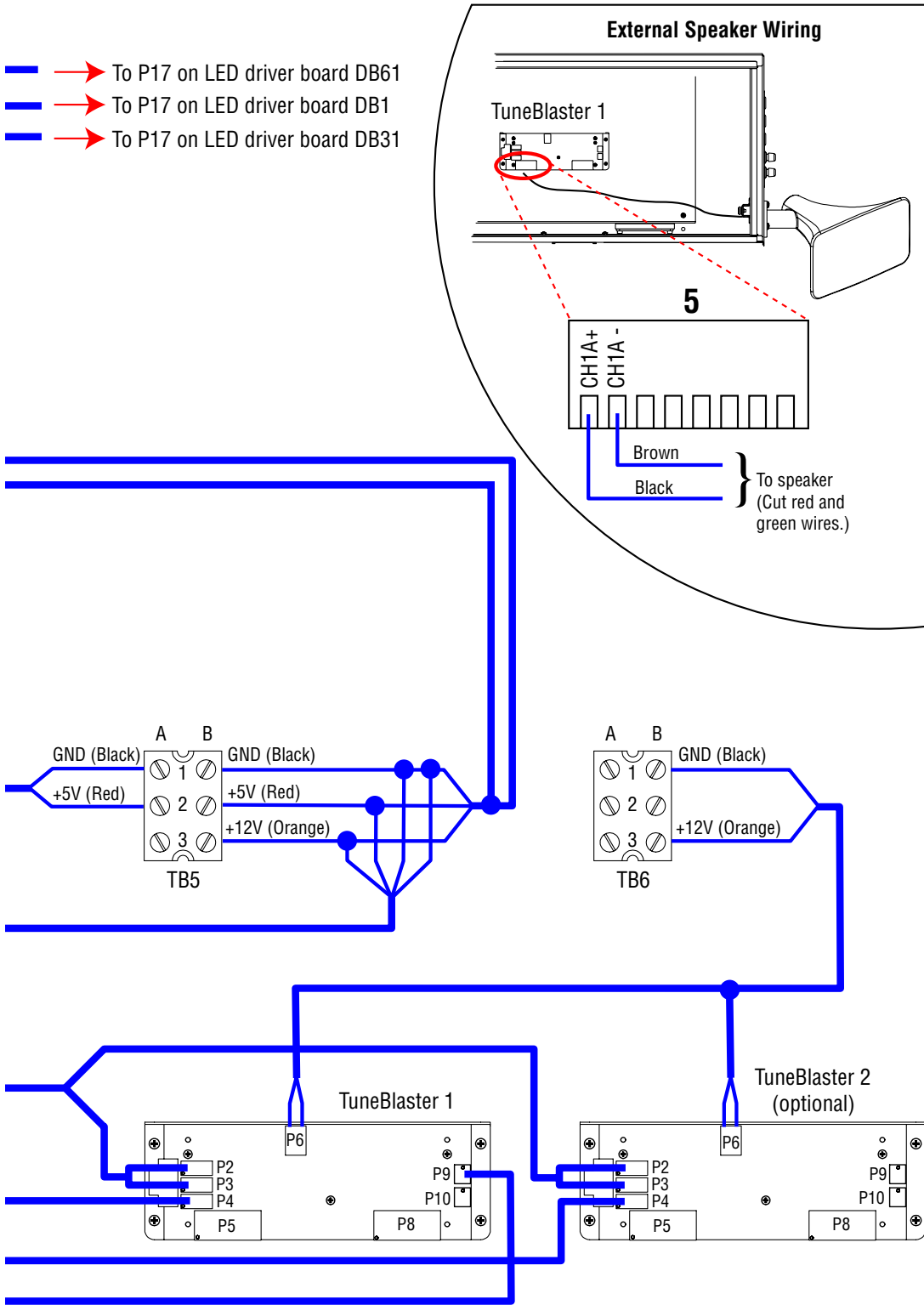

Advantech PCM-9579 controller board wiring for 320x96 sign

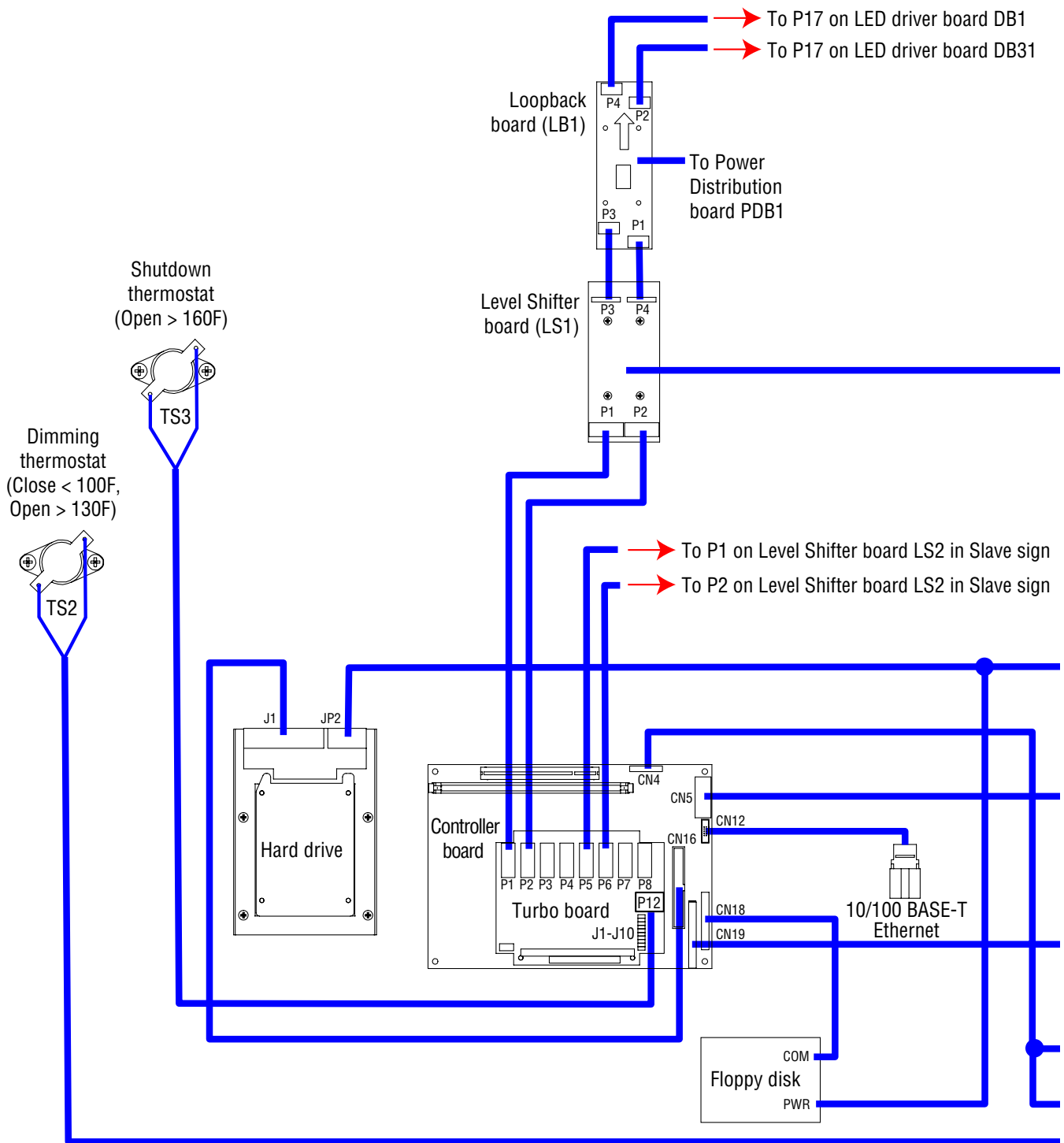

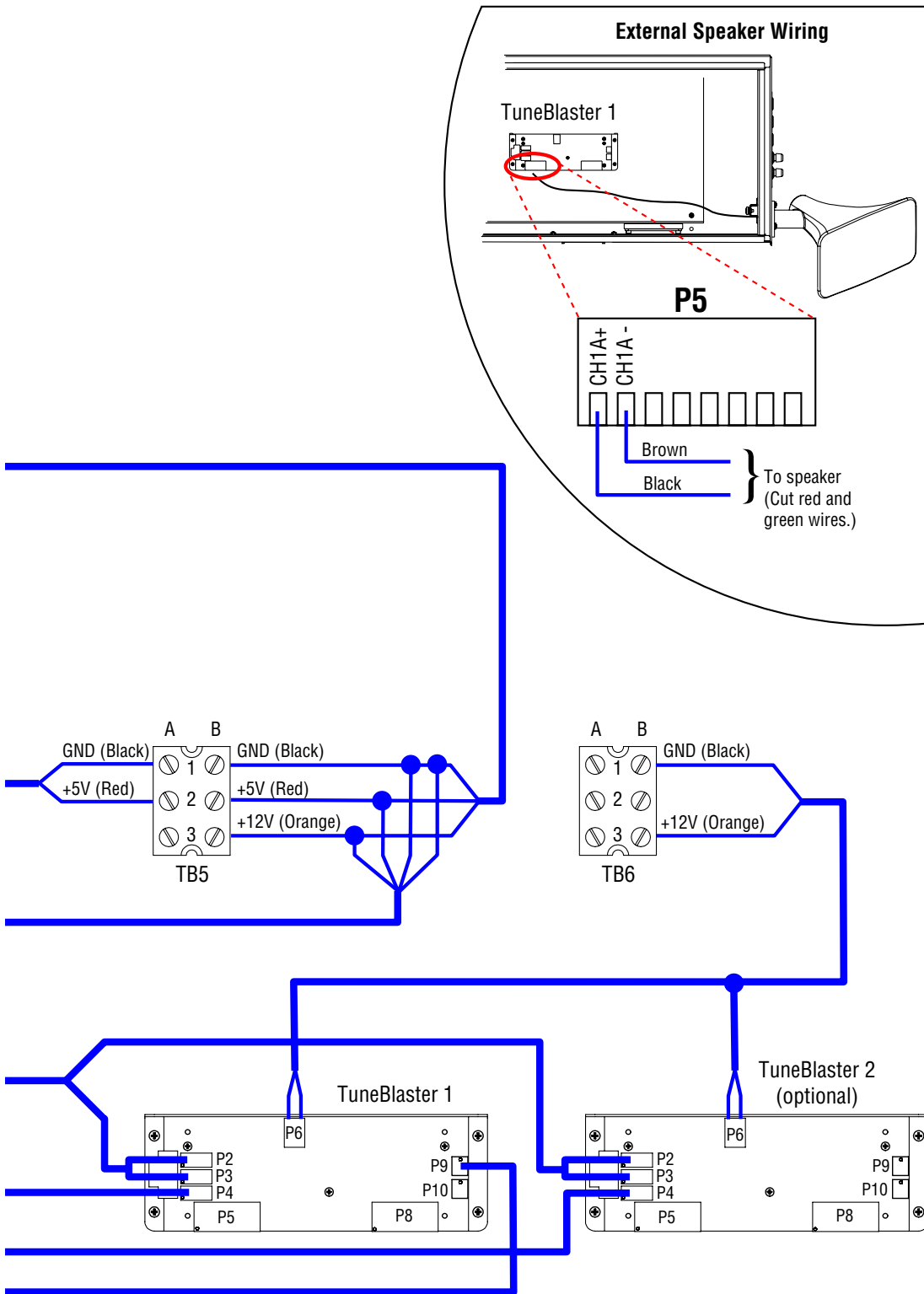

Advantech PCM-9579 controller board wiring for 320x80

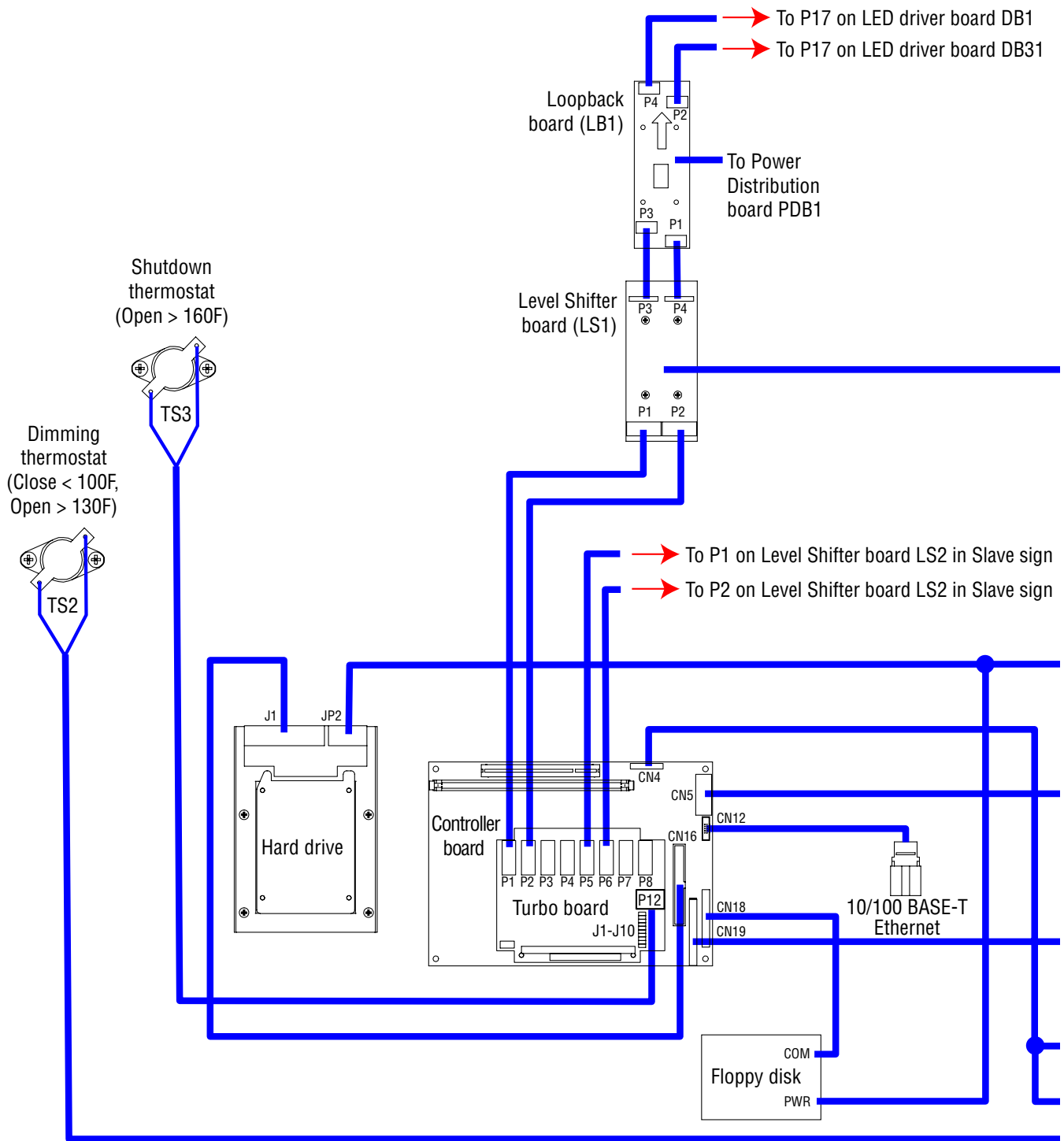

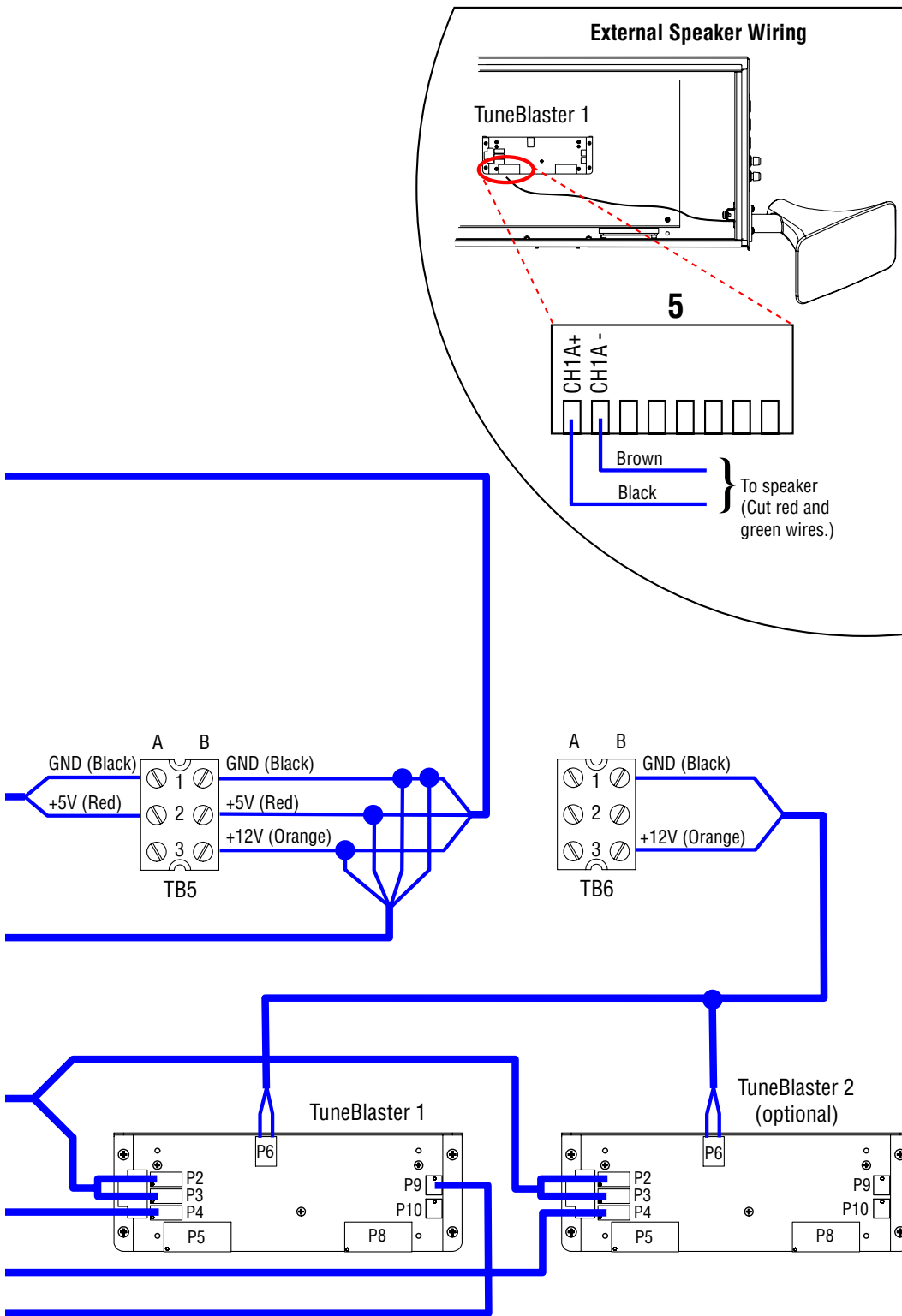

Advantech PCM-9579 controller board wiring for 320x64

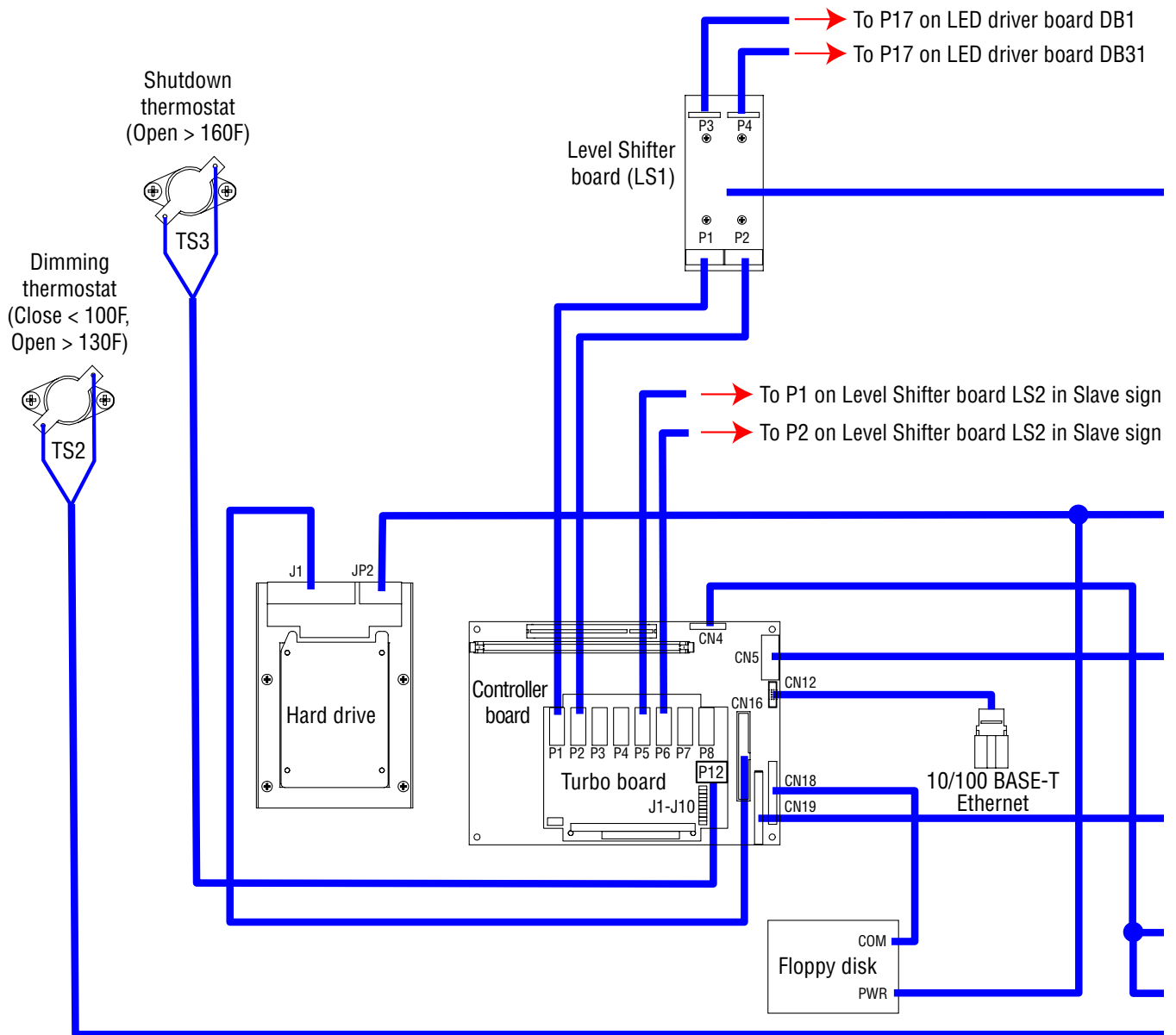

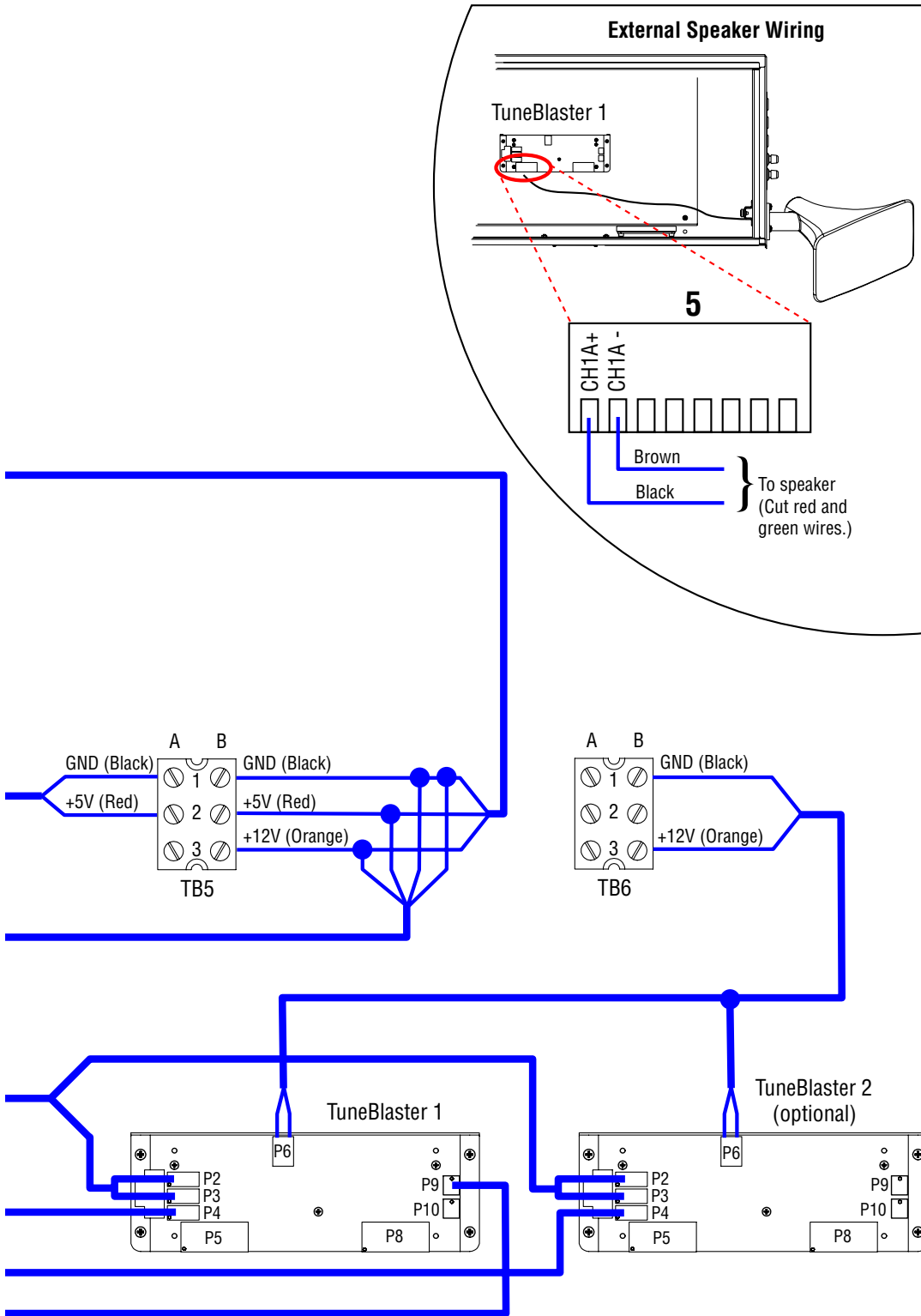

Arcom SBC-GX1 controller board wiring for 320x128

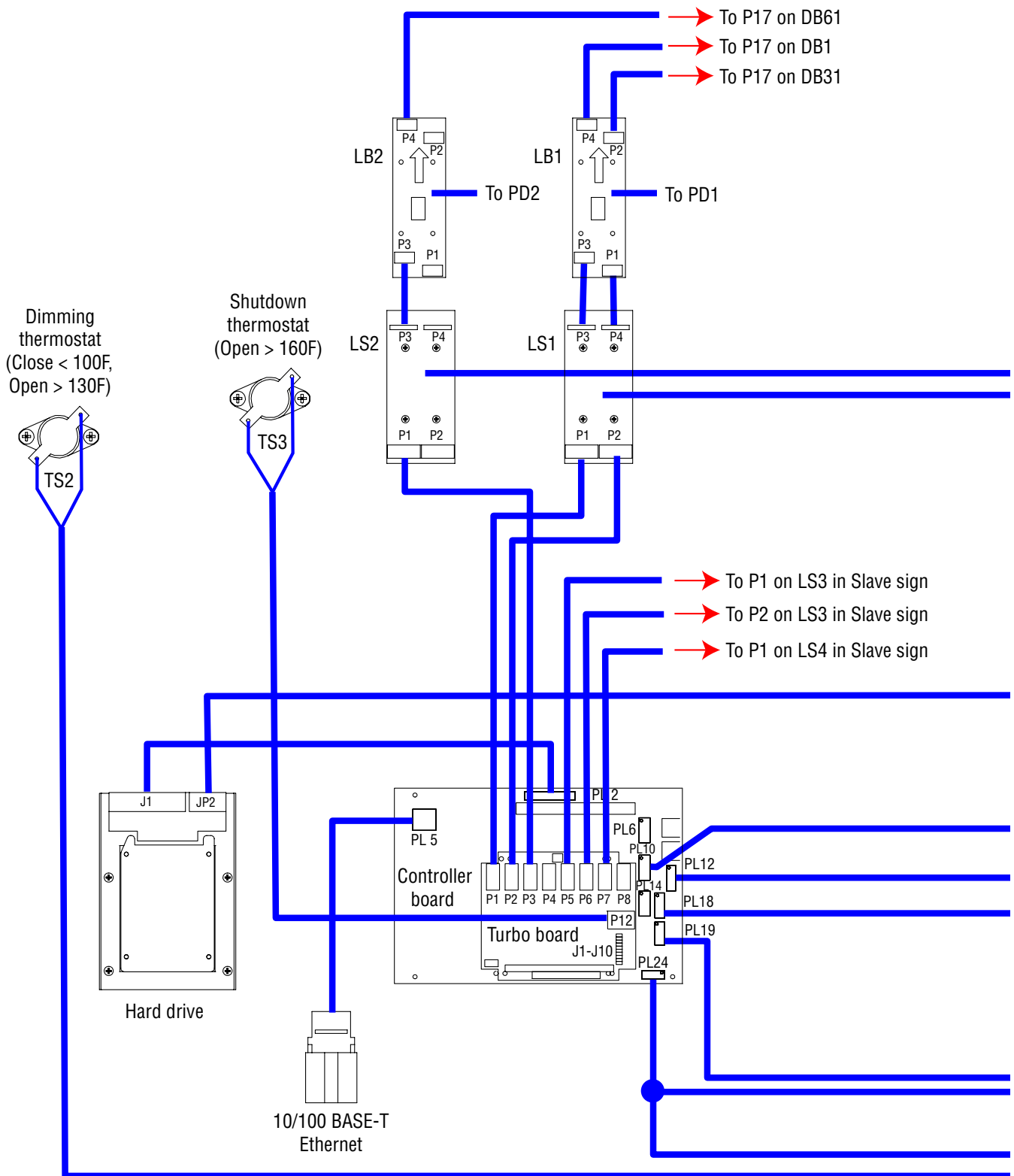

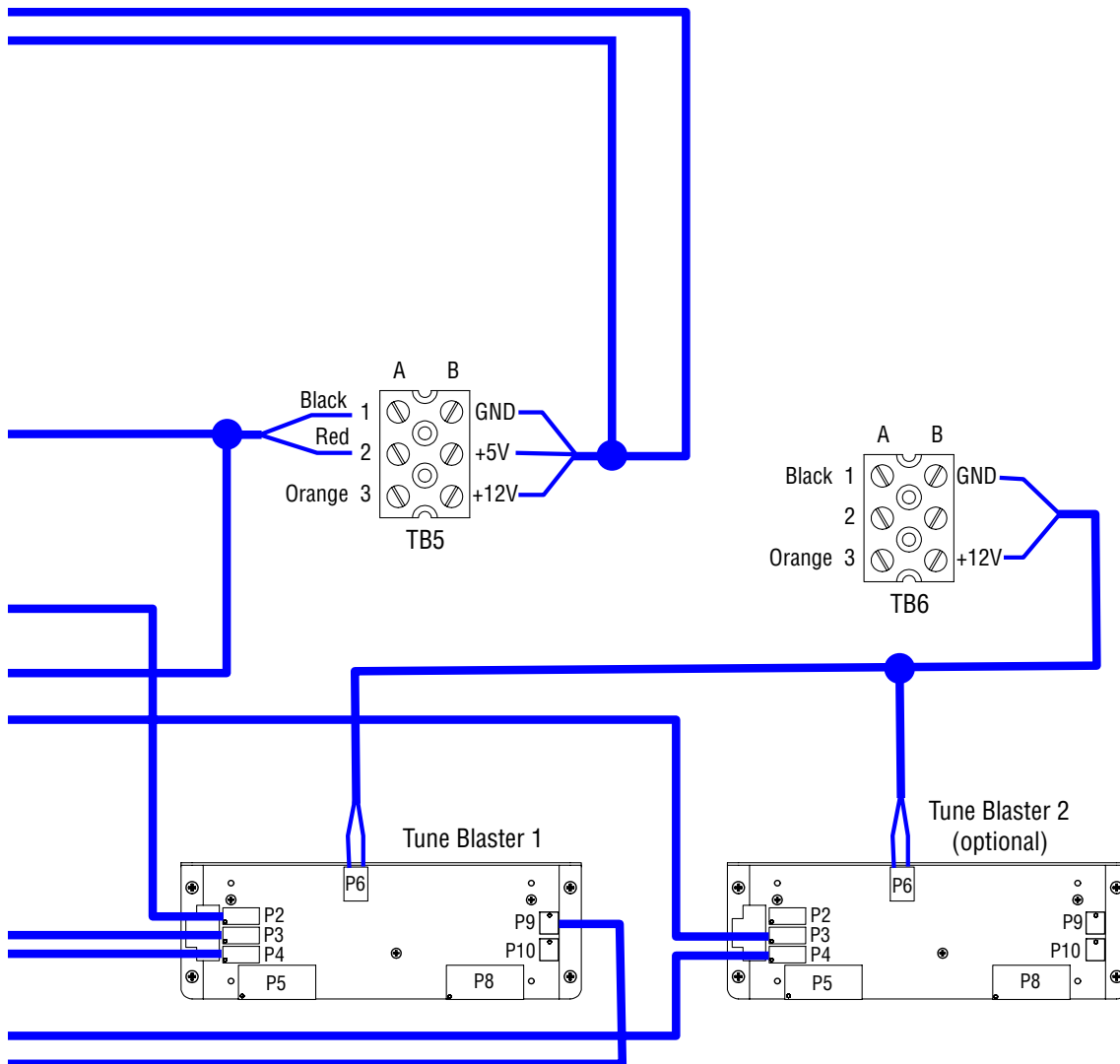

Arcom SBC-GX1 controller board wiring for 320x112

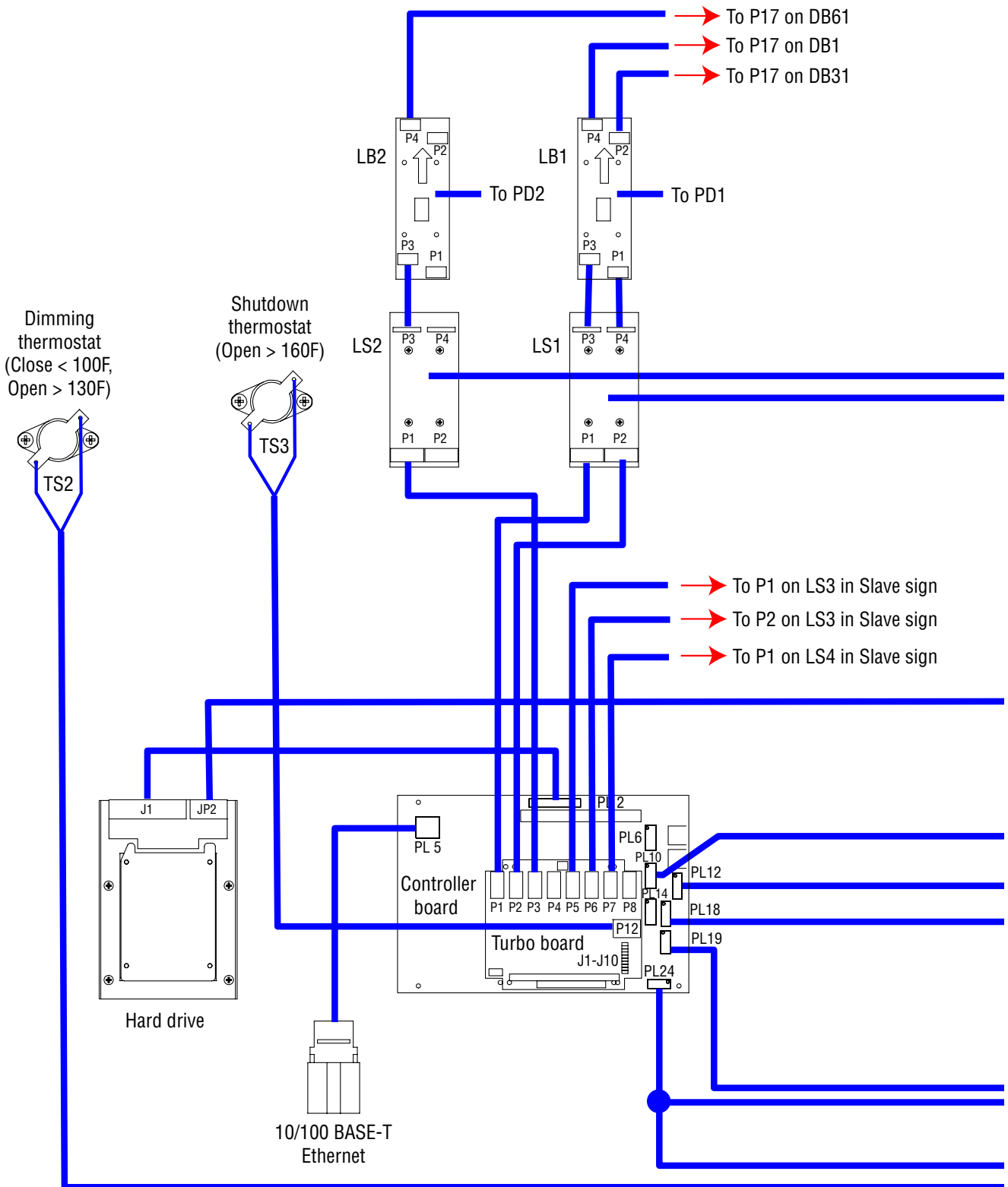

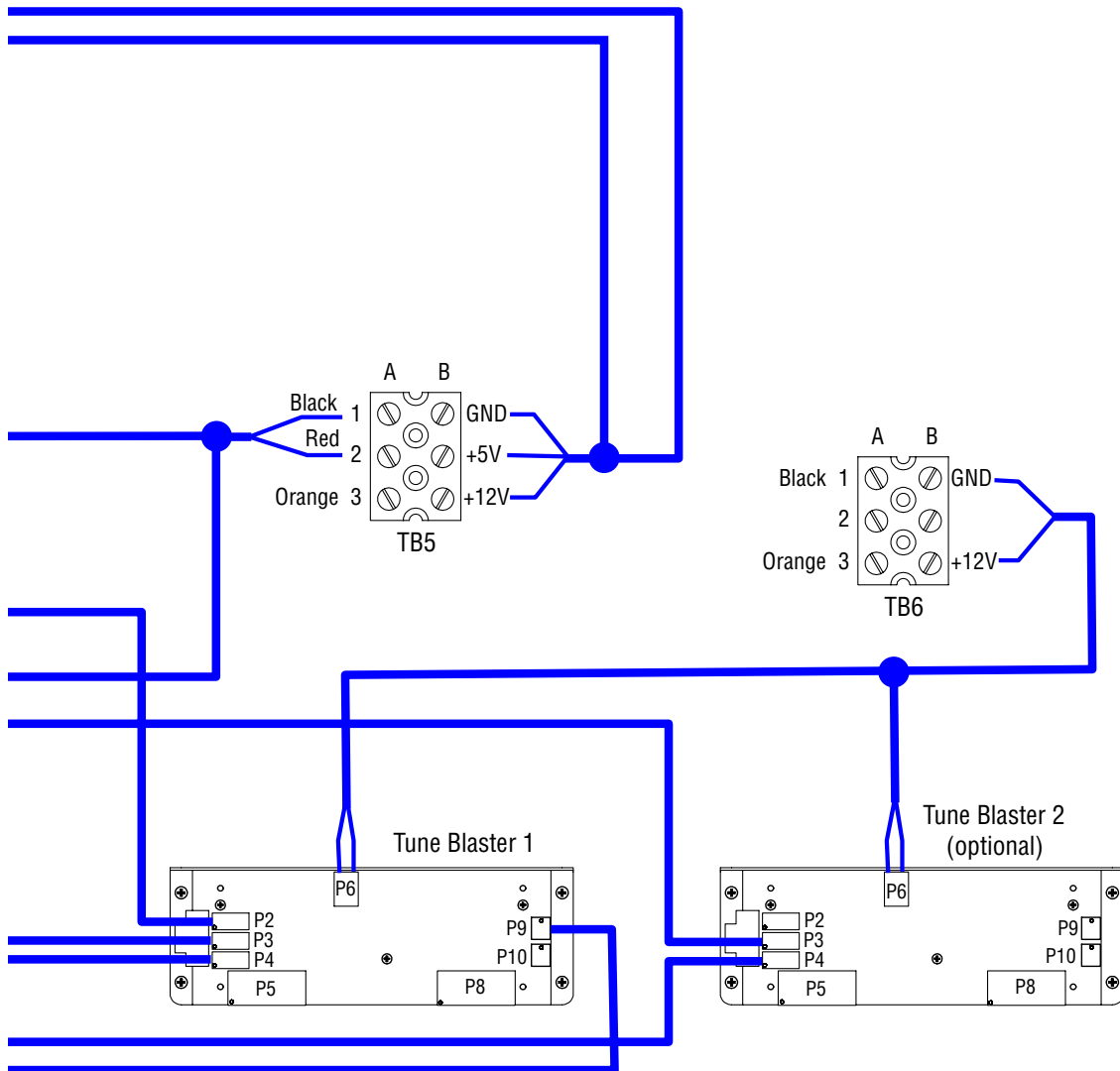

Arcom SBC-GX1 controller board wiring for 320x96

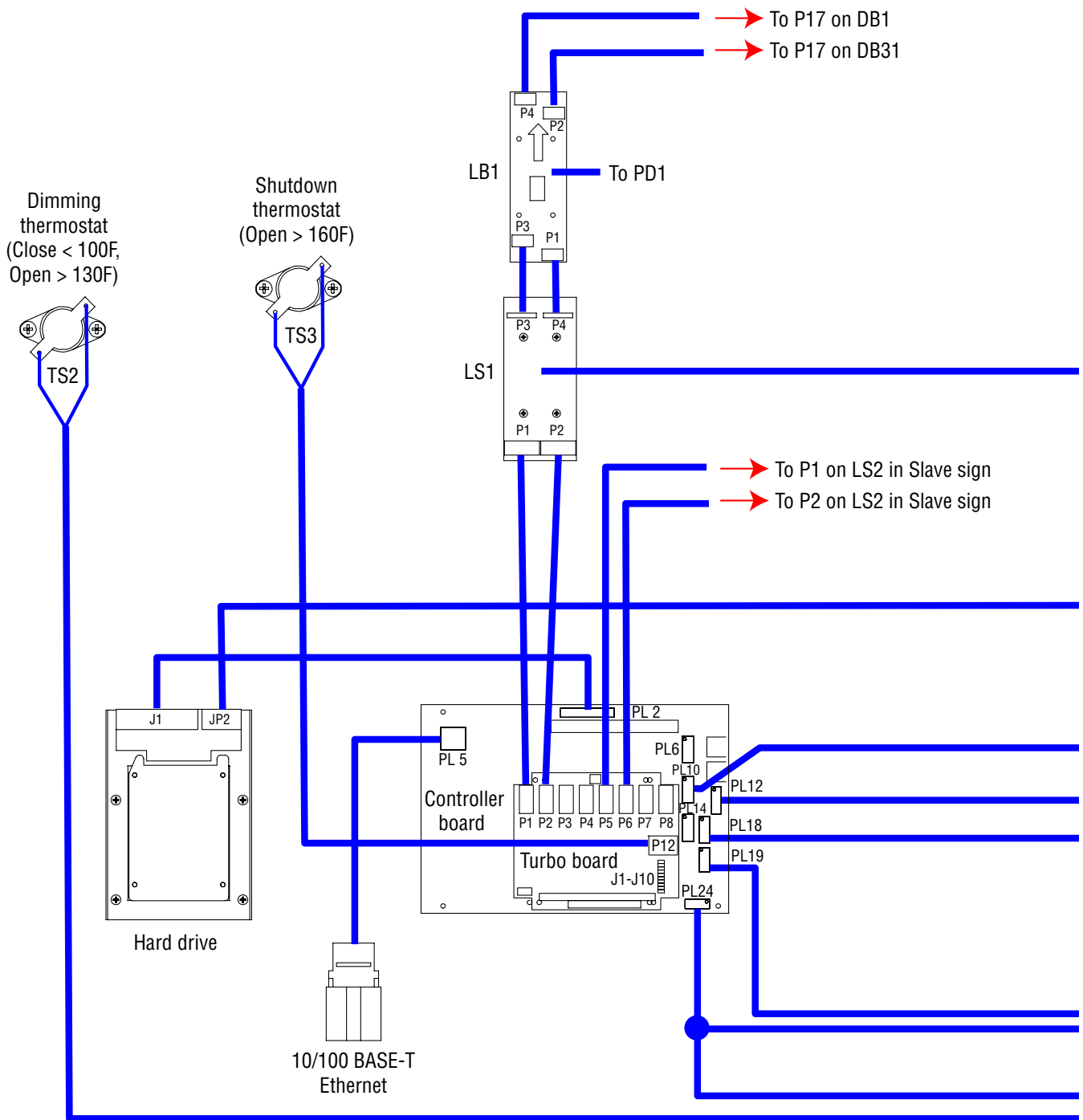

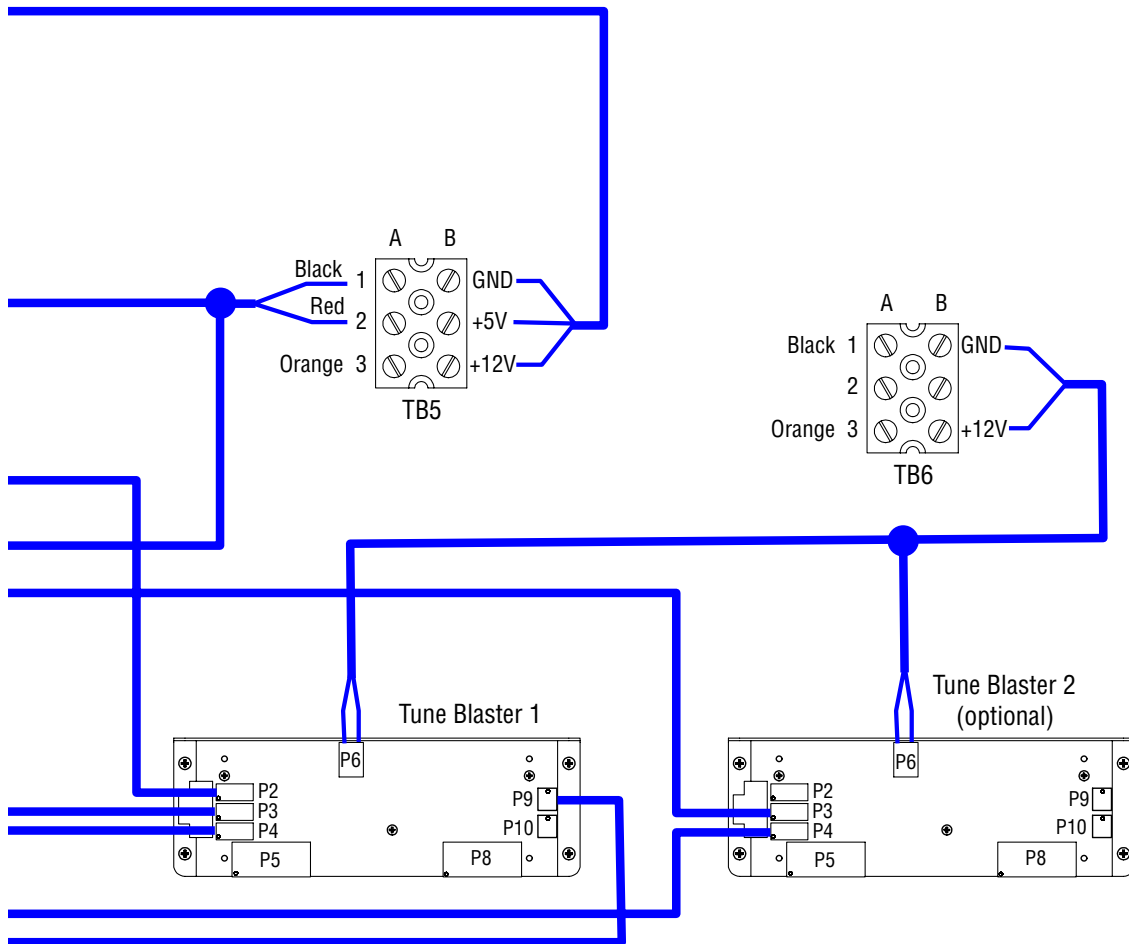

Arcom SBC-GX1 controller board wiring for 320x80

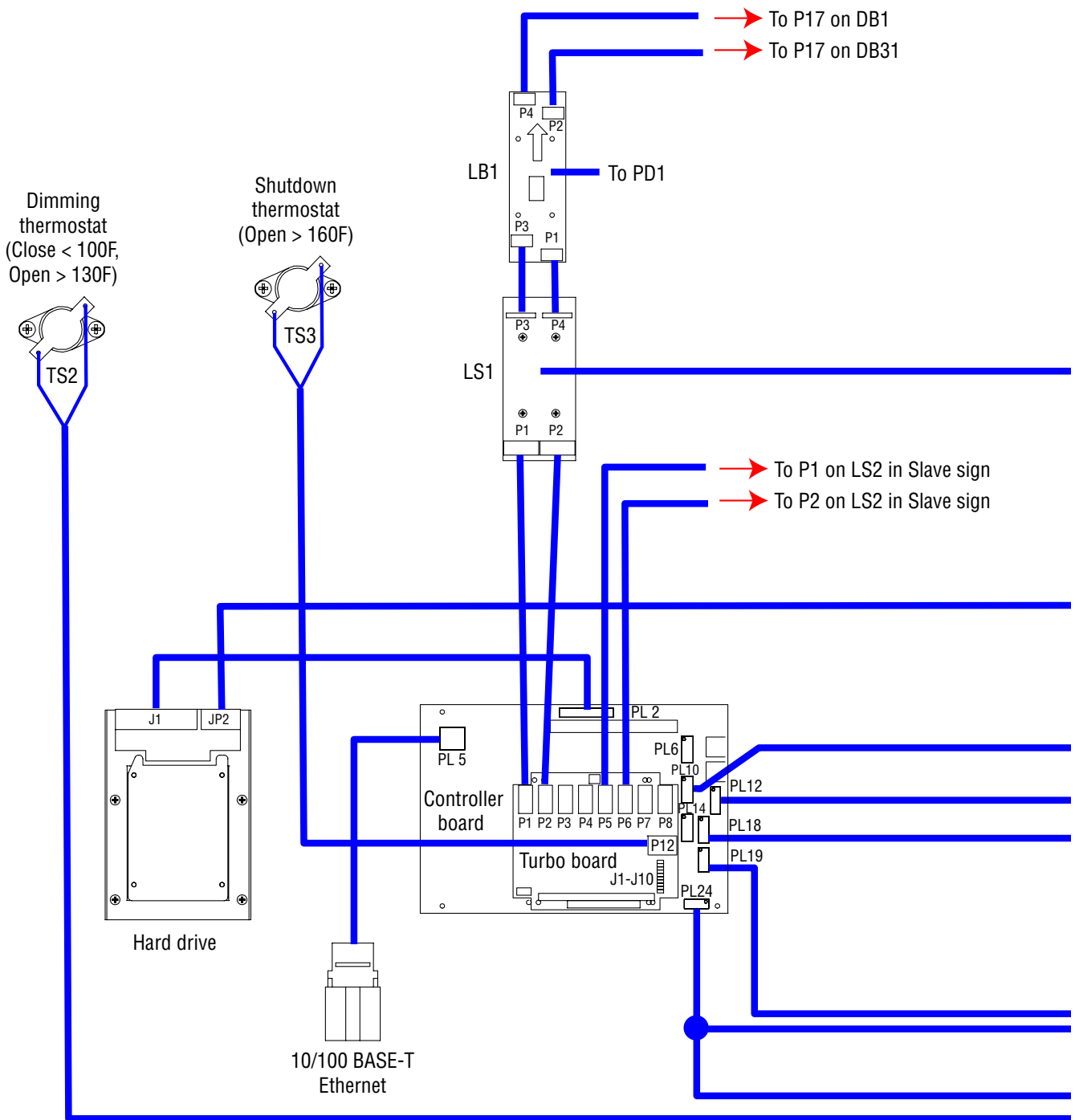

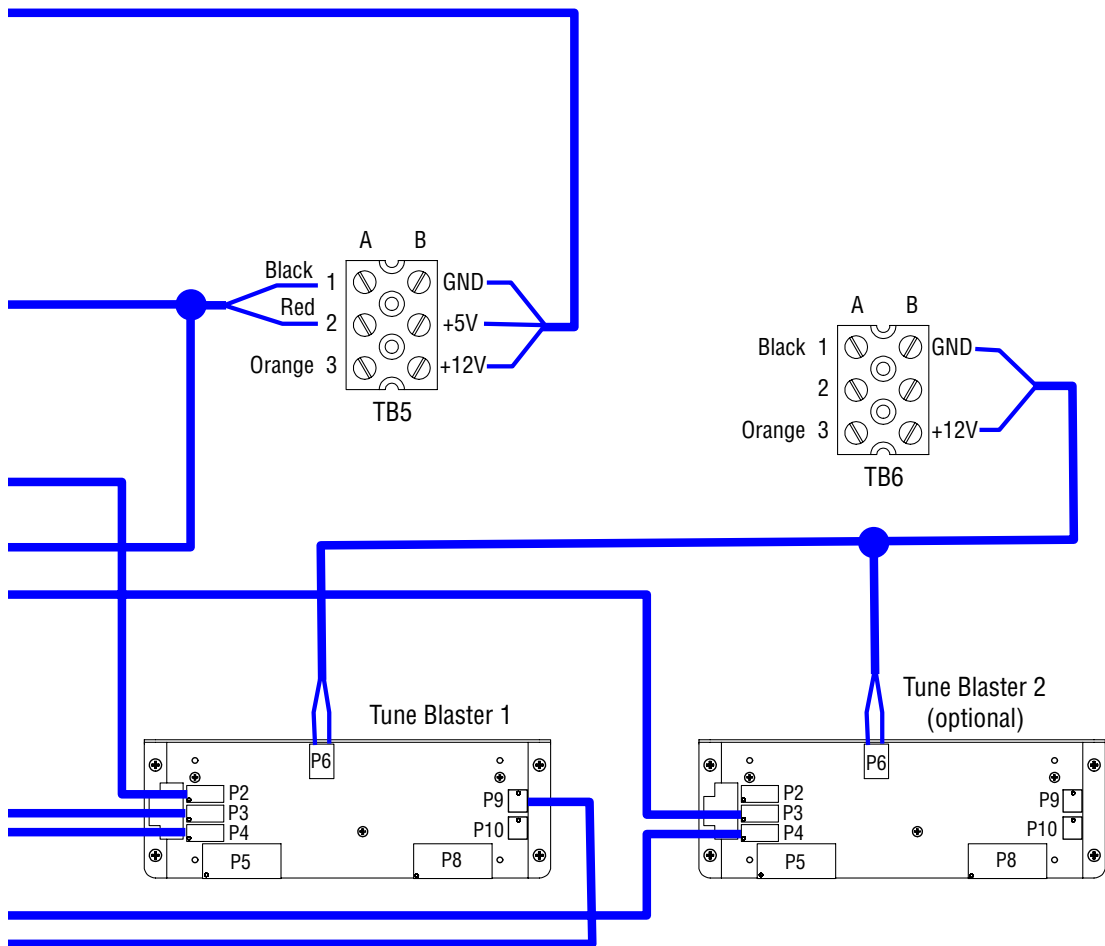

Arcom SBC-GX1 controller board wiring for 320x64

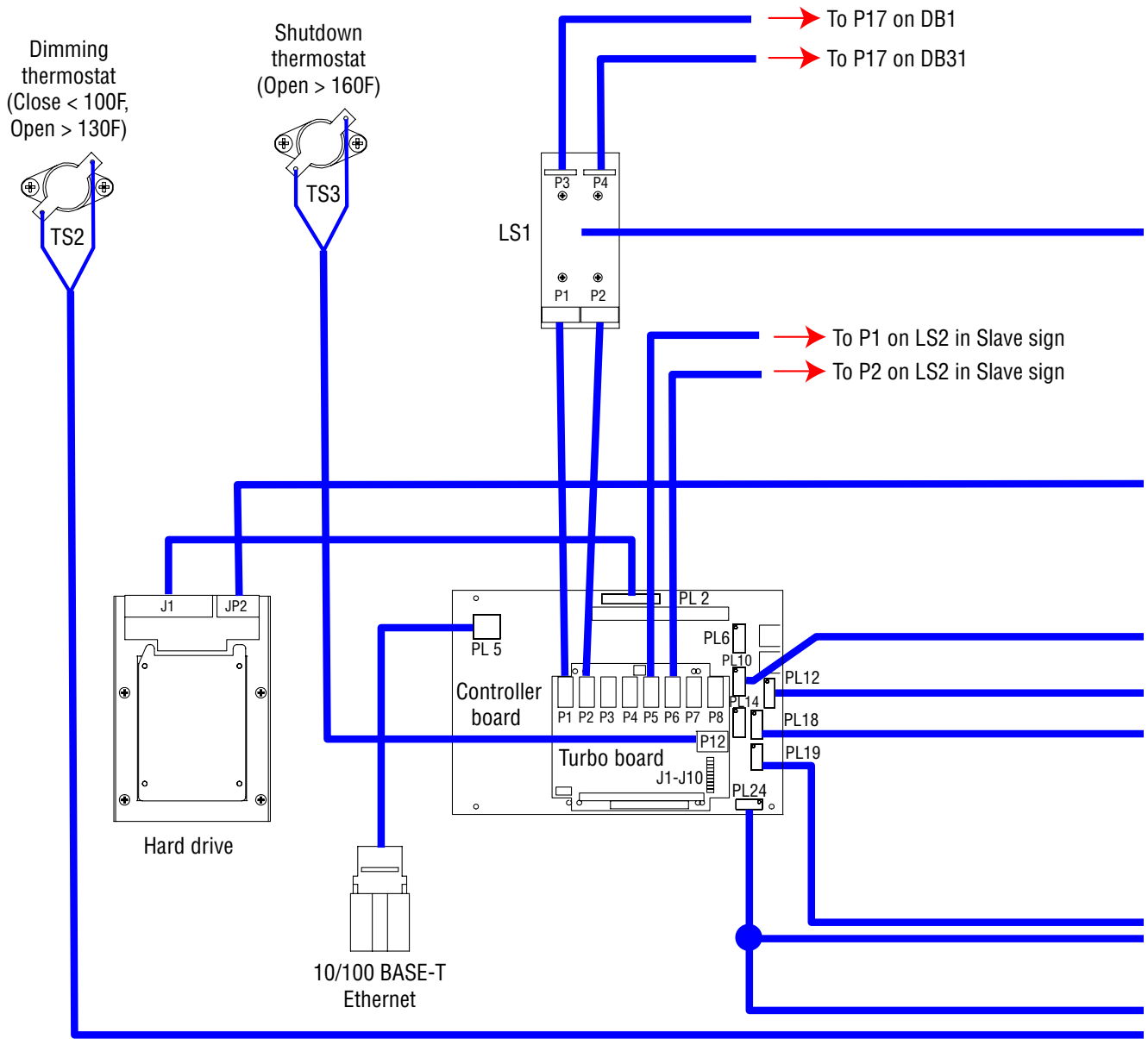

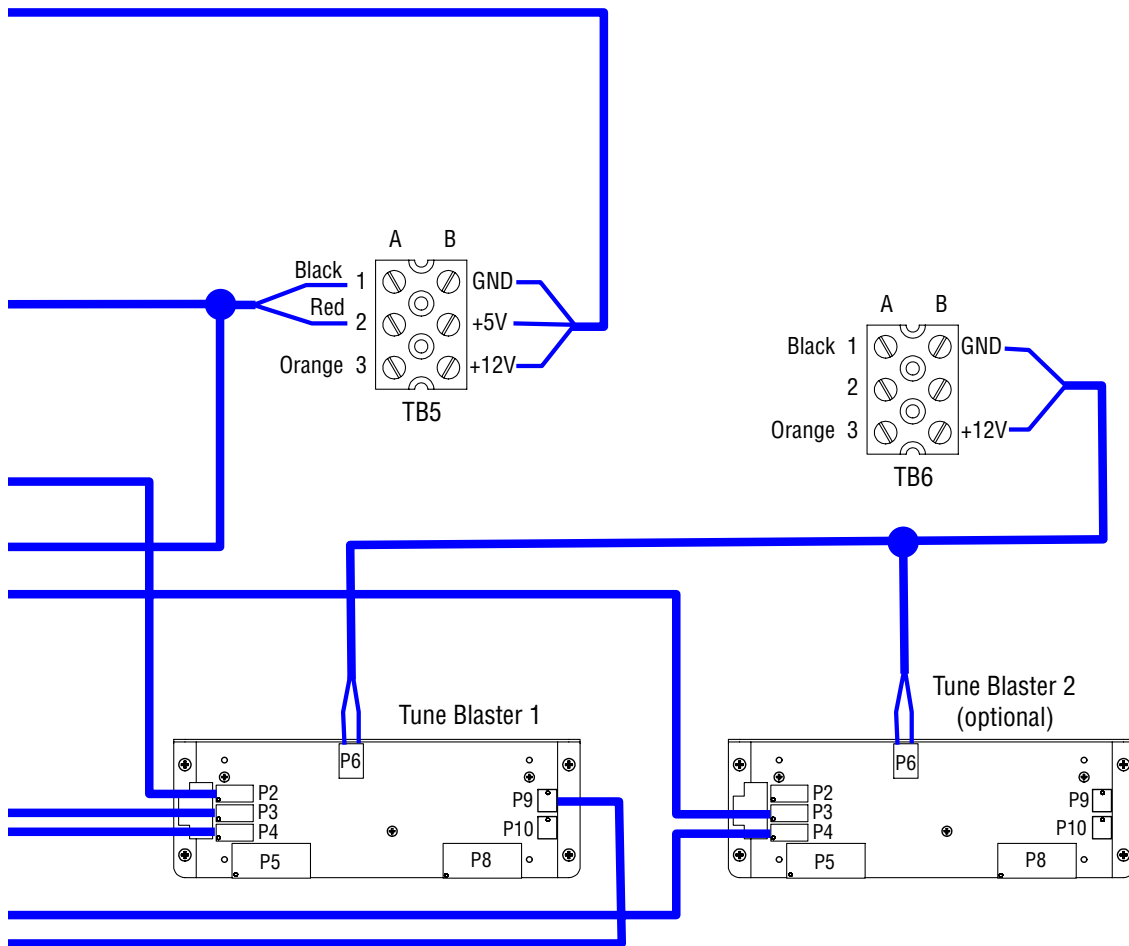

THIS PAGE INTENTIONALLY LEFT BLANK.