

Type C Sign Part Replacement (pn 1127-9426SP): Controller, Turbo, and TuneBlaster Boards

1.1 Description

1.1.1 Controller and turbo boards

The Arcom controller board is a 300 MHz computer that uses a National Semiconductor Geode GX1 MMX-enhanced processor. This computer translates incoming Ethernet messages and displays this data on AlphaVision PC signs. The controller board can be connected to a monitor, keyboard, and mouse. There is one controller board per sign. Back-to-back signs also have only one controller board.

The turbo board, which is attached to the controller board, serves as an interface between the controller and AlphaVision PC sign(s).

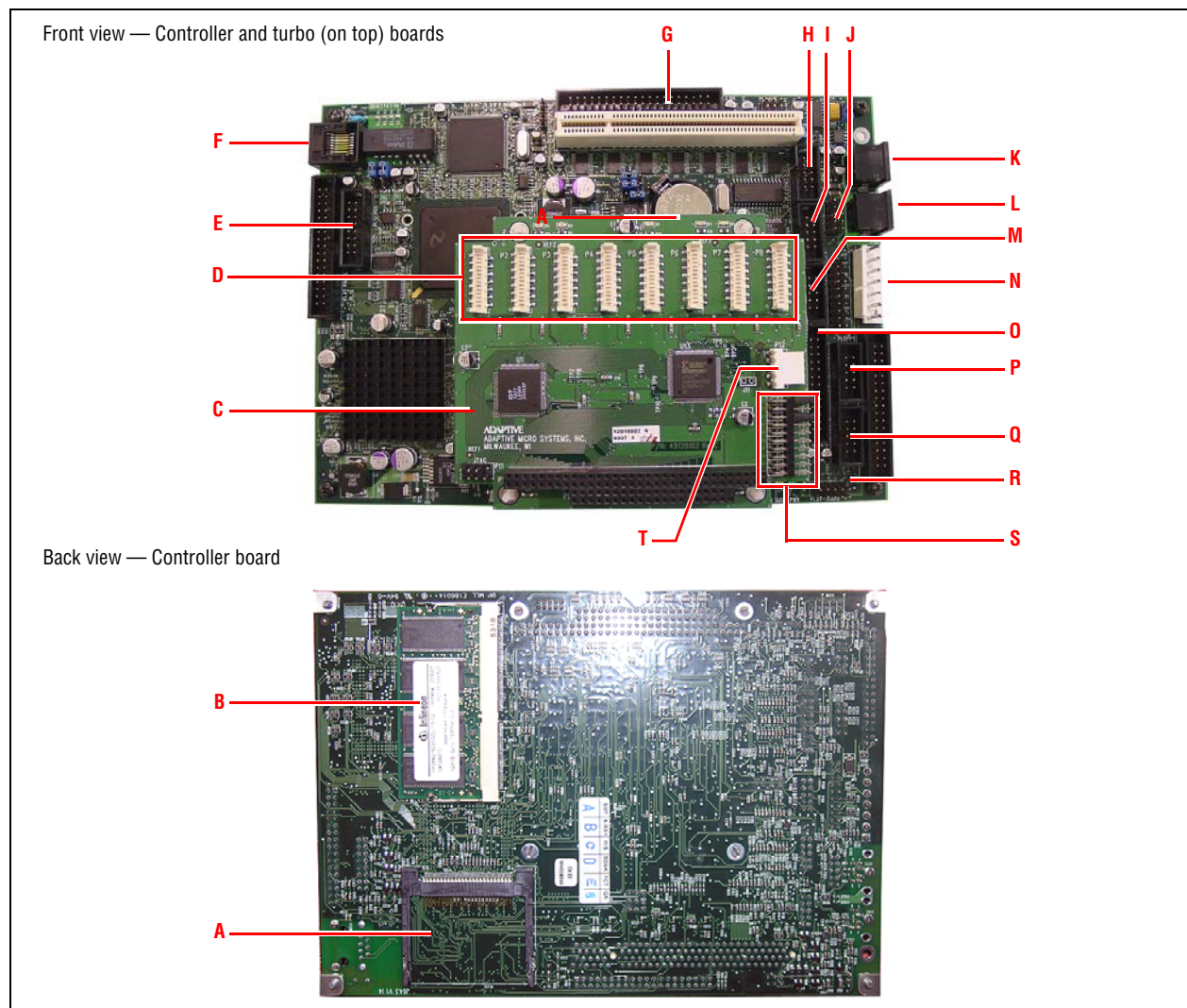

Item	PCB Label	Name	Description
A	PL25	CompactFlash socket	Allows 1x50 pin Type I and Type II CompactFlash cards. If there is an operating system on this card, the controller board will boot from the card if there are no hard disks connected to the controller board.
B	—	144-pin SODIMM	Supports 16, 32, 64, and 128MB 3.3V SDRAM module that conforms to either PC100 or PC133 specifications. The BIOS automatically detects the module size.
C	—	Turbo card	Serves as an interface between the controller board and AlphaVision PC sign.
D	P1 - P8	Turbo connectors	Turbo channels 1 through 8.
E	PL15	VGA CRT connector	Use cable (pn 1127-9055) to connect controller board to a VGA monitor.
F	PL5	Ethernet RJ45	100/10 BASE-T J45 Ethernet connector.
G	PL2	IDE disk interface	Connects to a hard disk.
H	PL6	COM3 RS232 serial port	Not used.
I	PL10	COM4 RS232 serial port	Connects to P2 connector on TuneBlaster 1 board.
J	PL8	USB ports	Used to connect stacklight option.
K	PL7	PS/2 keyboard	Allows direct attachment of a keyboard to controller board.
L	PL9	PS/2 mouse	Allows direct attachment of a mouse to controller board.
M	PL14	COM4 RS485/422 serial port	Not used.
N	PL12	Power connector	Supplies 5V power to controller and turbo boards.
O	PL16	Parallel port	Not used.
P	PL18	COM2 RS232 serial port	Connects to P3 connector on TuneBlaster 2 board.
Q	PL19	COM1 RS232 serial port	Connects to P3 on TuneBlaster 1 board.
R	PL24	16-bit SoundBlaster	Connects to P4 on TuneBlaster 1 board and P4 on TuneBlaster 2 board.
S	J1 - J10	Turbo board jumpers	Used to set the following parameters: <ul style="list-style-type: none"> • J1 through J7 = Memory addressing (must be set as shown below): <ul style="list-style-type: none"> <input type="checkbox"/> J1 = ON <input type="checkbox"/> J2 = OFF <input type="checkbox"/> J3 = ON <input type="checkbox"/> J4 through J7 = OFF • J8 = Dimming: <ul style="list-style-type: none"> <input type="checkbox"/> J8 OFF = 100% brightness <input type="checkbox"/> J8 ON = 50% brightness • J9 and J10 = IO addressing (must be set as shown below): <ul style="list-style-type: none"> <input type="checkbox"/> J9 = OFF <input type="checkbox"/> J10 = OFF
T	P12	Thermostat connection	Used to shut down the sign when the temperature becomes greater than 160°F.

1.1.2 TuneBlaster board

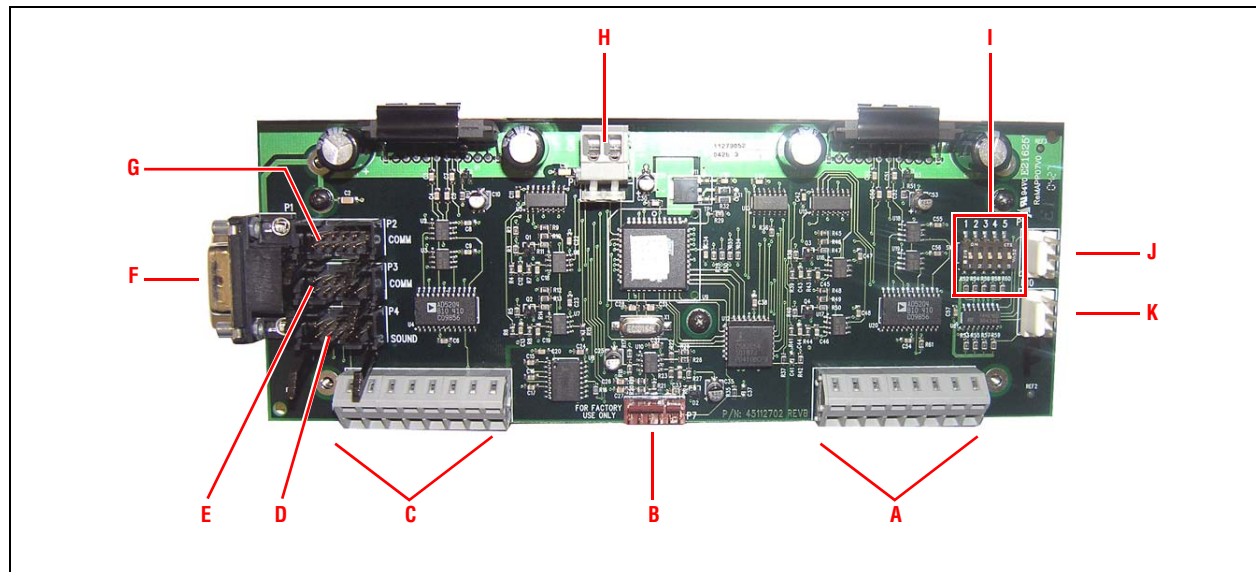

This board sends audio signals from the controller to up to 8 speakers. Each channel on a board can power two speakers. A 4-channel board is shown below:

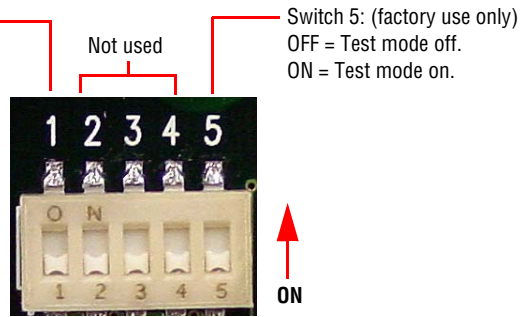

Item	PCB Label	Name	Description
A	P8	Channel 3 and 4 speaker connections	Allows 4 speaker hookups (2 per channel).
B	P7	ISP programming connector	Factory use only.
C	P5	Channel 1 and 2 speaker connections	Allows 4 speaker hookups (2 per channel).
D	P4 SOUND	SoundBlaster input	Connects to PL24 on controller board.
E	P3 COM	RS232 TuneBlaster board interface	TuneBlaster 1 board connects to PL19 on controller board. TuneBlaster 2 board connects to PL18 on controller board.
F	P1	RS232 controller board interface	P1 is a DB9 connector.
G	P2 COM	RS232 controller board interface	P2 is a box-type connector.
H	P6	Power connector	Supplies 12V power to board.
I	SW1	DIP switches	Used to set TuneBlaster board parameters: Switch 1: _____ OFF on TuneBlaster 1 board. ON on TuneBlaster 2 board. Switch 5: (factory use only) OFF = Test mode off. ON = Test mode on.
J	P9	Thermostat connectors	Used to dim the sign when the temperature inside becomes greater than 130°F.
K	P10		

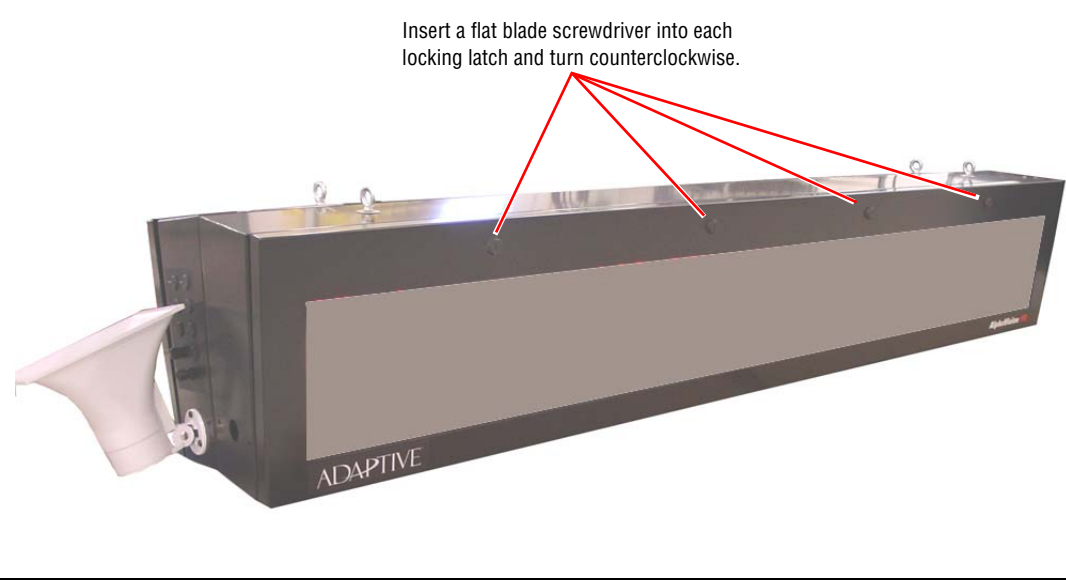

1.2 Installation

1	Prevent electrostatic discharge (ESD) or “static” damage to the replacement part.	
	For safe handling of ESD-sensitive parts, see TechMemo #00-0005.	
2	Remove power from the sign.	
3	Open the sign door. For back-to-back signs, open the controller board side. This side is marked by a label on the bottom of the signs:	Insert a flat blade screwdriver into each locking latch and turn counterclockwise.
		
		4

5**Part replacement instructions:**

- To replace the controller and turbo boards, go to step 6.
- To replace TuneBlaster board(s), go to step 7.

6**Controller and turbo boards replacement:**

- Disconnect all the cables from the current controller and turbo boards.
- Remove the four screws that hold the current controller board to the sign.
- Attach the replacement controller and turbo boards.
- Connect all the cables to the replacement controller and turbo boards.
- Go to step 8.

7**TuneBlaster board(s) replacement:**

- Disconnect all the cables from the current TuneBlaster board(s).
- Remove the four screws that hold the current TuneBlaster board(s) to the sign.
- Attach the replacement TuneBlaster boards to the sign. Make sure the DIP switches of the replacement TuneBlaster board(s) match the settings on the current board(s):

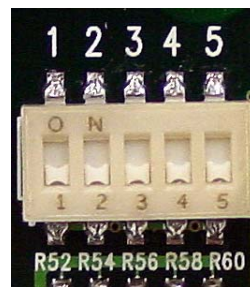

TuneBlaster 1
DIP switch settings:
All switches OFF.

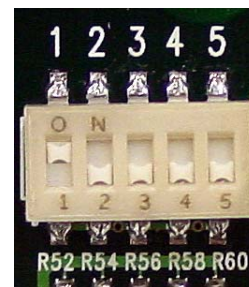

TuneBlaster 2
DIP switch settings
Only switch 1 is ON.

- Connect all the cables to the replacement TuneBlaster board(s).
- Go to step 8.

8**Close the sign. Apply power to the sign.**

1.3 Appendix

1.3.1 Controller board pinouts

1.3.1.1 PL2 - IDE disk interface

PL2 - IDE Disk Interface

40 way 0.1" boxed pin header

Pin	Signal Name	Pin	Signal Name
1	/RESET	2	Ground
3	D7	4	D8
5	D6	6	D9
7	D5	8	D10
9	D4	10	D11
11	D3	12	D12
13	D2	14	D13
15	D1	16	D14
17	D0	18	D15
19	Ground	20	+5V
21	DREQ	22	Ground
23	/IOW	24	Ground
25	/IOR	26	Ground
27	/IOCHRDY	28	Ground
29	DACK	30	Ground
31	INTR	32	/IOCS16
33	SA1	34	No Connect
35	SA0	36	SA2
37	/CS0	38	/CS1
39	LED	40	Ground

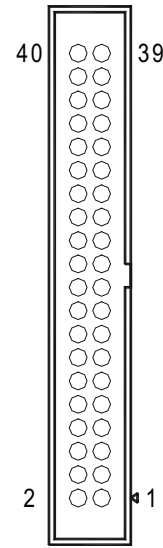

1.3.1.2 PL5 - Ethernet RJ45

PL5 - Ethernet RJ45

8 way RJ45

Pin	Signal Name
1	TX+
2	TX-
3	RX+
4	No Connect
5	No Connect
6	RX-
7	No Connect
8	No Connect

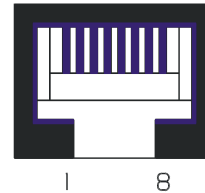

1.3.1.3 PL6 - COM3 RS232 serial port

PL6 - COM3 RS232 Serial Port

10 pin 0.1" boxed pin header.

Pin	Signal Name	Pin	Signal Name
1	DCD	2	DSR
3	RXD	4	RTS
5	TXD	6	CTS
7	DTR	8	RI
9	GND	10	No Connect

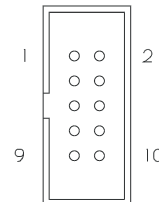

1.3.1.4 PL7 - PS/2 keyboard

PL7- PS/2 Keyboard
6-pin Mini-DIN

Pin	Signal Name
1	KB DATA
2	No Connect
3	Ground
4	+5V
5	KB CLOCK
6	No Connect

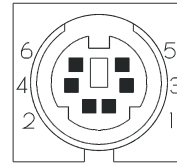

1.3.1.5 PL8 - USB ports

PL8 - USB Ports
10 way 0.1" dual row pin header

Pin	Signal Name	Pin	Signal Name
1	VBUS-1	2	VBUS-2
3	DNEG-1	4	DNEG-2
5	DPOS-1	6	DPOS-2
7	Ground	8	Ground
9	Ground	10	Ground

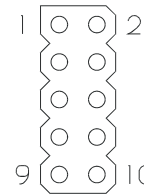

1.3.1.6 PL9 - PS/2 mouse

PL9- PS/2 Mouse
6-pin Mini-DIN

Pin	Signal Name
1	MS DATA
2	No Connect
3	Ground
4	+5V
5	MS CLOCK
6	No Connect

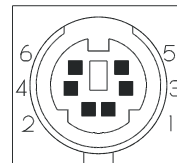

1.3.1.7 PL10 - COM4 RS232 serial port

PL10 – COM4 RS232 Serial Port
10 pin 0.1" boxed pin header.

Pin	Signal Name	Pin	Signal Name
1	DCD	2	DSR
3	RXD	4	RTS
5	TXD	6	CTS
7	DTR	8	RI
9	GND	10	No Connect

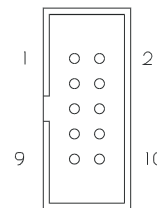

1.3.1.8 PL12 -Power connector

PL12 - Power Connector
7-pin locking power connector, Molex part number 26-60-4070.

Pin	Signal Name
1	+5V
2	Ground
3	Ground
4	+12V
5	+3.3V (Not Used)
6	Ground
7	+5V

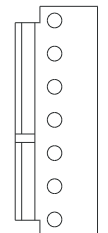

1.3.1.9 PL14 - COM4 RS485/422 serial port**PL14 – COM4 RS485/422 Serial Port**

10 pin 0.1" boxed pin header

Pin	Signal Name	Pin	Signal Name
1	No Connect	2	No Connect
3	Ground	4	Ground
5	TXB/(RXB 485)	6	TXA/(RXA 485)
7	RXB	8	RXA
9	Ground	10	No Connect

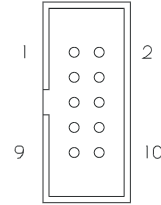
**1.3.1.10 PL15 - VGA CRT connector****PL15 -VGA CRT connector**

16 way 0.1" boxed pin header

Pin	Signal Name	Pin	Signal Name
1	RED	2	Ground
3	GREEN	4	No Connect
5	BLUE	6	Ground
7	+5V (Fused)	8	No Connect
9	Ground	10	Ground
11	Ground	12	HSYNC
13	DDCSDA	14	VSYNC
15	DDCSCL	16	No Connect

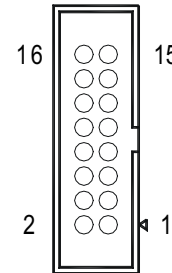
**1.3.1.11 PL18 - COM2 RS232 serial port****PL18 – COM2 RS232 Serial Port**

10 way 0.1" boxed pin header.

Pin	Signal Name	Pin	Signal Name
1	DCD	2	DSR
3	RXD	4	RTS
5	TXD	6	CTS
7	DTR	8	RI
9	GND	10	No Connect

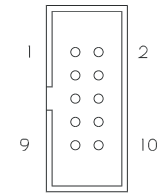

Note:- This pin-out is designed to provide a 1:1 connection to a 9 way IDC D-Type plug.

1.3.1.12 PL19 - COM1 RS232 serial port**PL19 – COM1 RS232 Serial Port**

10 way 0.1" boxed pin header

Pin	Signal Name	Pin	Signal Name
1	DCD	2	DSR
3	RXD	4	RTS
5	TXD	6	CTS
7	DTR	8	RI
9	GND	10	No Connect

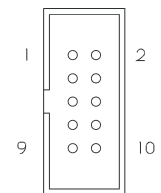

Note:- This pin-out is designed to provide a 1:1 connection to a 9 way IDC D-Type plug.

1.3.1.13 PL24 - 16-bit SoundBlaster**PL24 - 16-bit SoundBlaster**

10 way 0.1" pin header

Pin	Signal Name	Pin	Signal Name
1	Ground	2	MIC IN
3	Ground	4	LEFT IN
5	Ground	6	RIGHT IN
7	Ground	8	LEFT OUT
9	Ground	10	RIGHT OUT

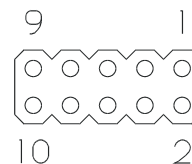

1.3.2 Controller board wiring diagram

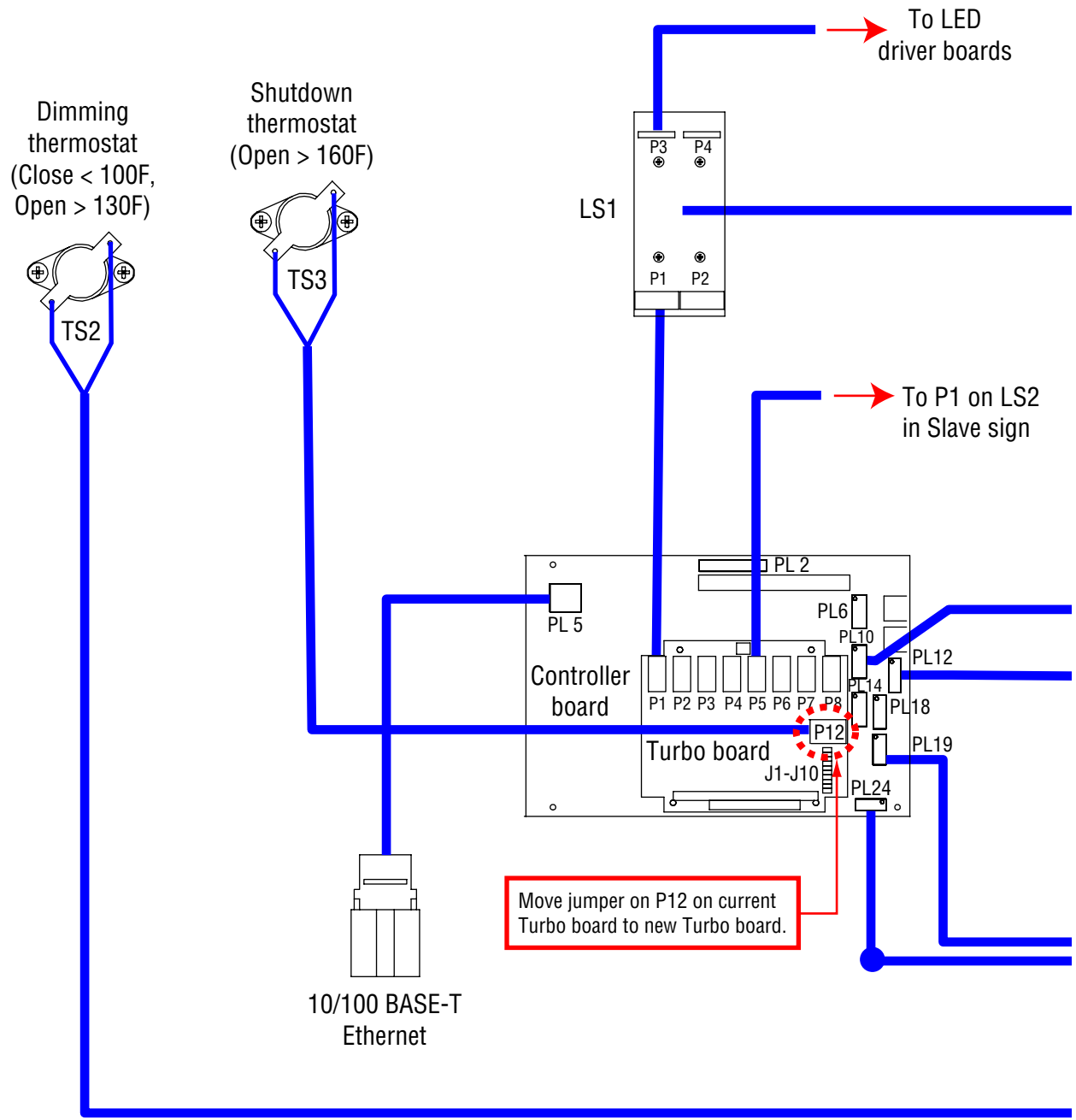

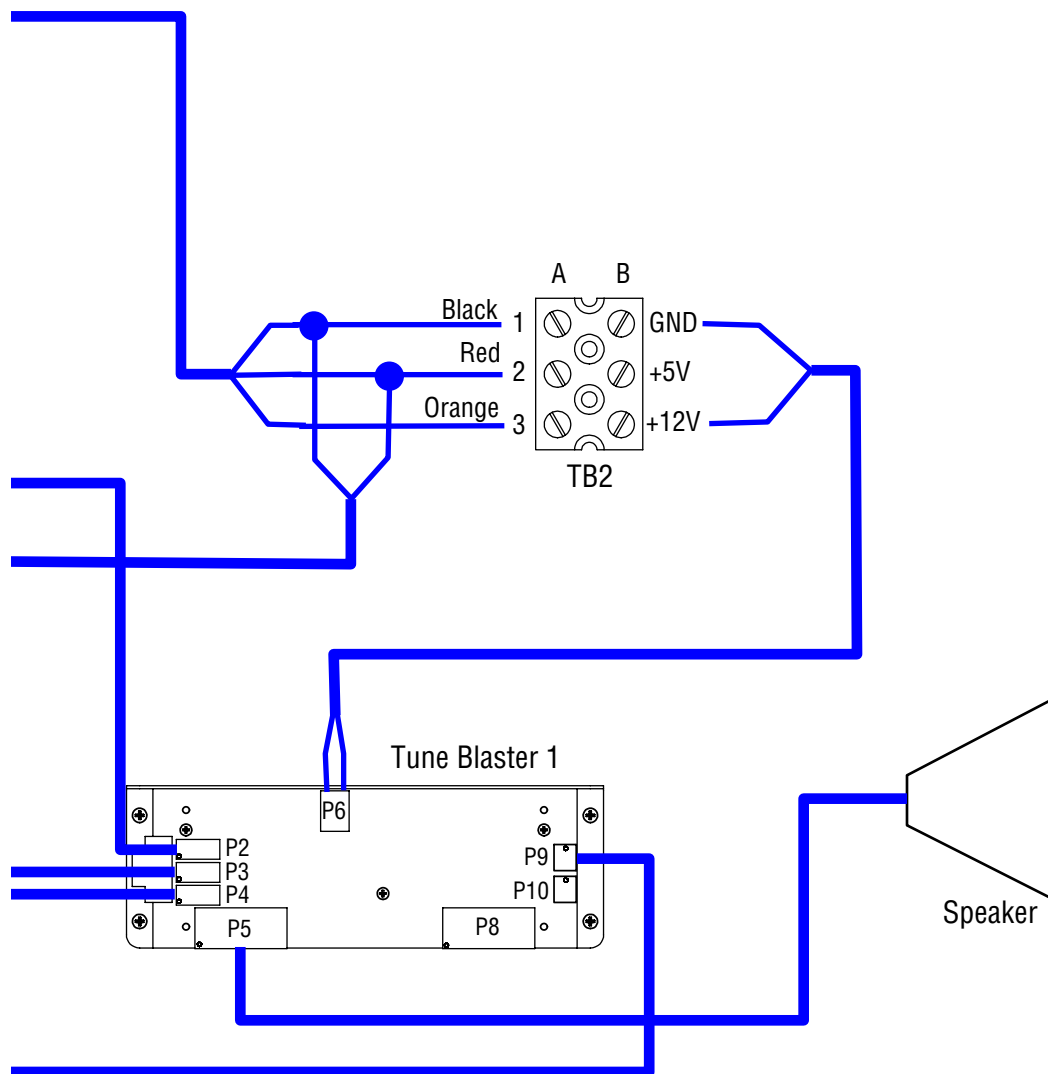

1.3.3 LED driver board interconnection

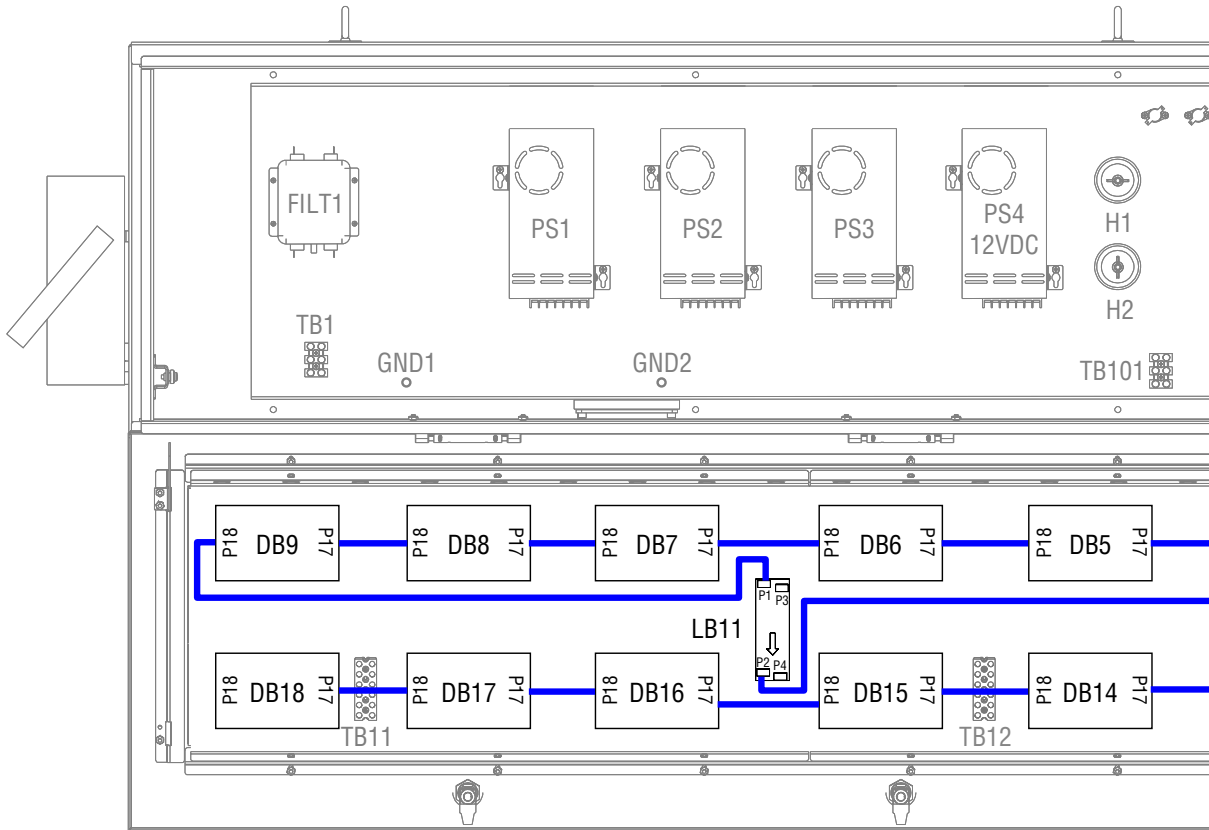

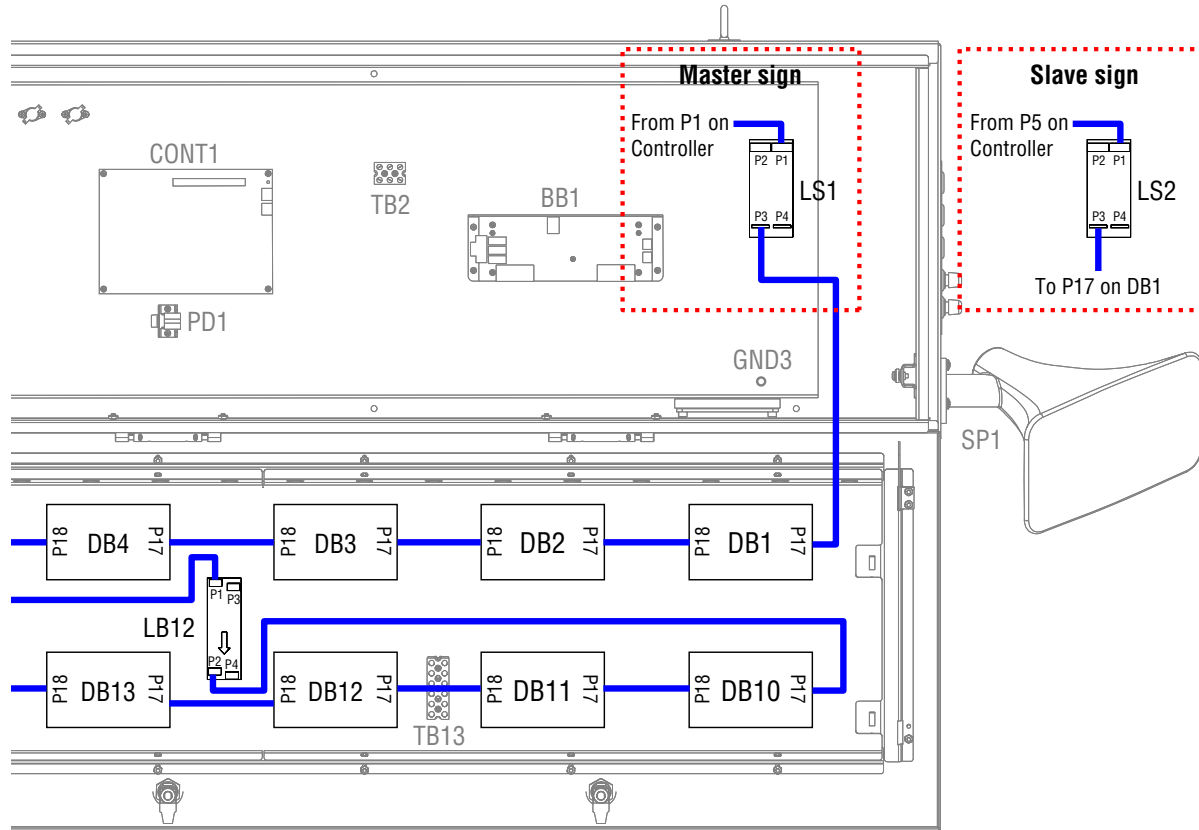

1.3.4 DC power wiring

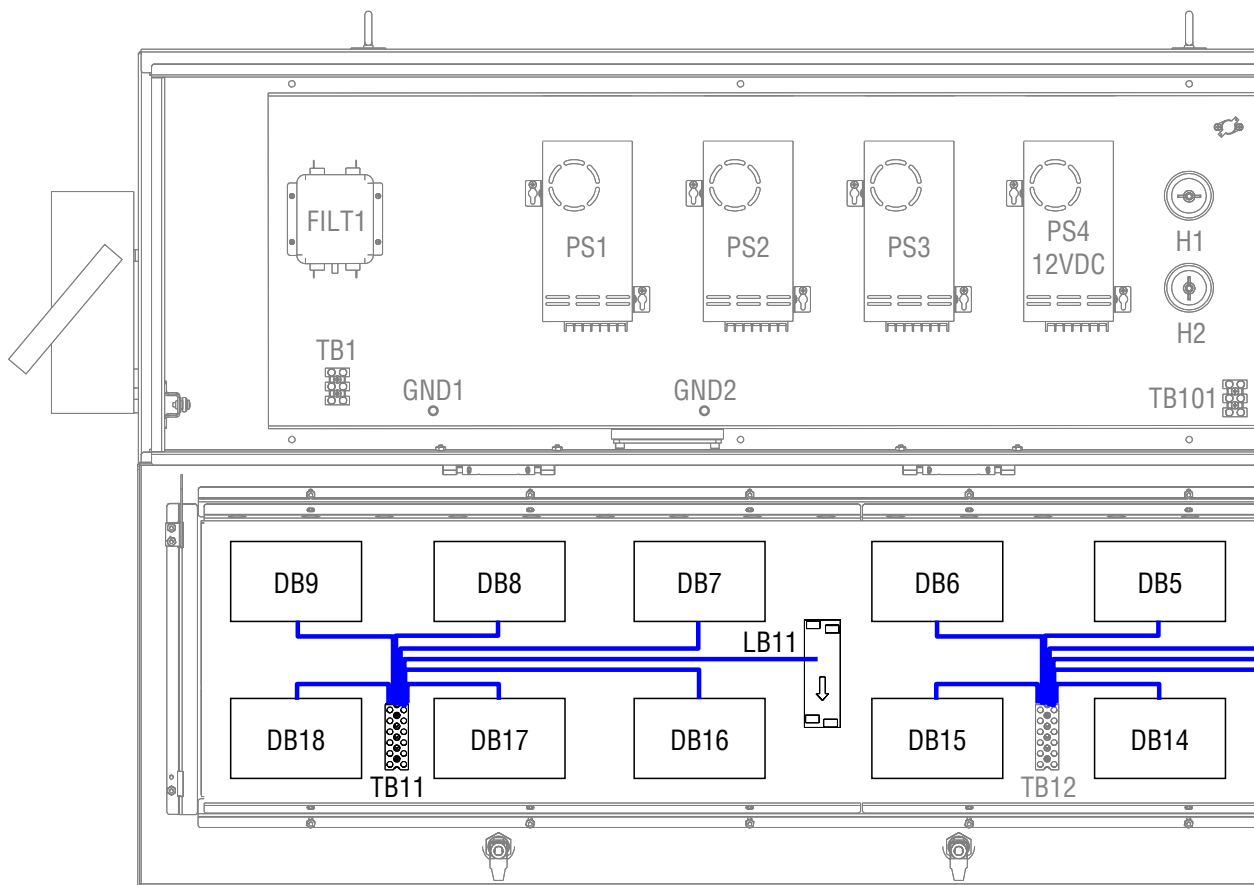

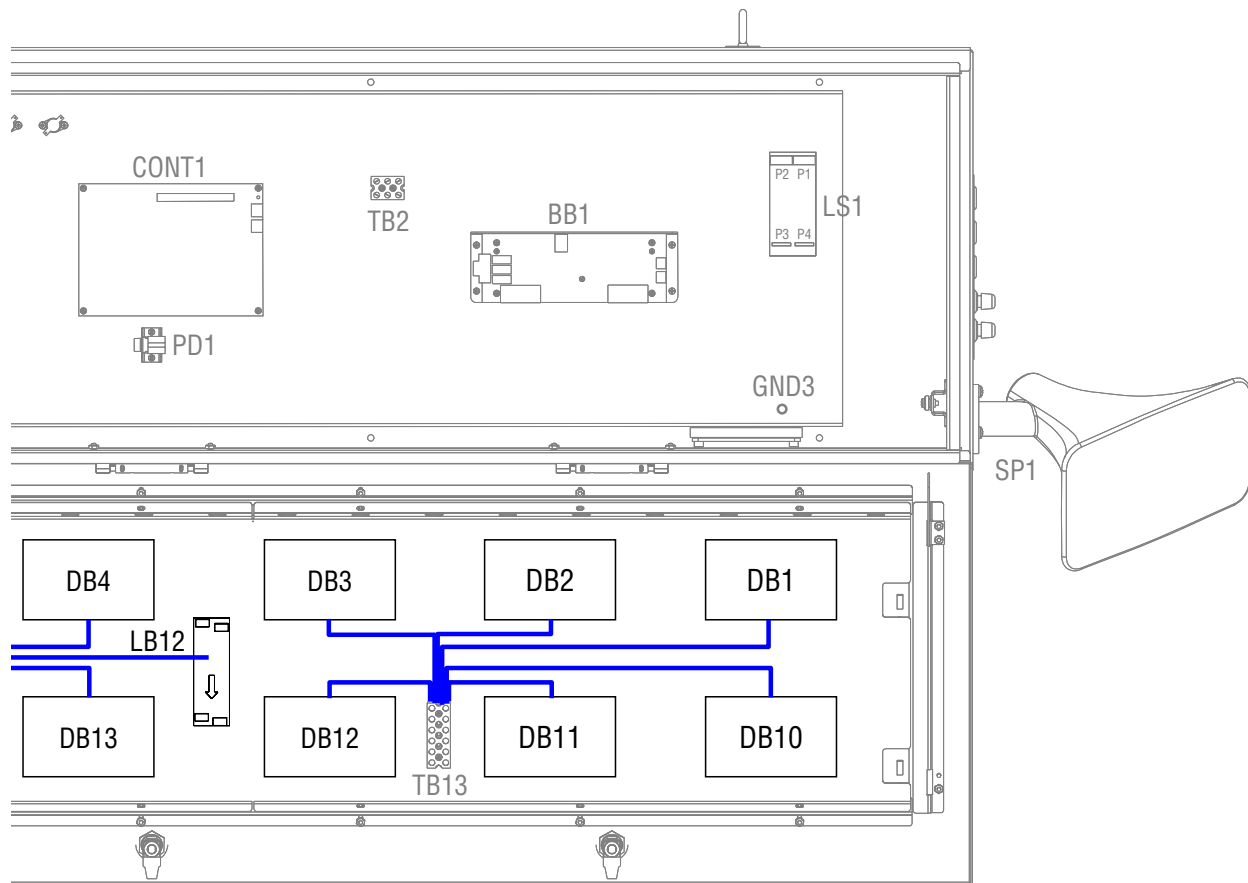



© Copyright 2004 Adaptive Micro Systems LLC. All rights reserved.
Adaptive Micro Systems • 7840 North 86th Street • Milwaukee, WI 53224 USA • 414-357-2020 • 414-357-2029 (fax) • <http://www.adaptivedisplays.com>
Trademarked names appear throughout this document. Rather than list the names and entities that own the trademarks or insert a trademark symbol with each mention of the trademarked name, the publisher states that it is using names for editorial purposes and to the benefit of the trademark owner with no intention of improperly using the trademark.
The following are trademarks of Adaptive Micro Systems: Adaptive, Alpha, AlphaLert, AlphaNET, AlphaNet plus, AlphaEclipse, AlphaPremiere, AlphaTicker, AlphaVision, AlphaVision InfoTracker, Automode, BetaBrite, BetaBrite Director, BetaBrite Messaging Software, Big Dot, Director, EZ KEY II, EZ95, PagerNET, PPD, PrintPak, Serial Clock, Smart Alec, Solar, TimeNet. The distinctive trade dress of this product is a trademark claimed by Adaptive Micro Systems LLC.
Due to continuing product innovation, specifications in this manual are subject to change without notice.

November 15, 2004

9711-2716A
