

Installation Manual

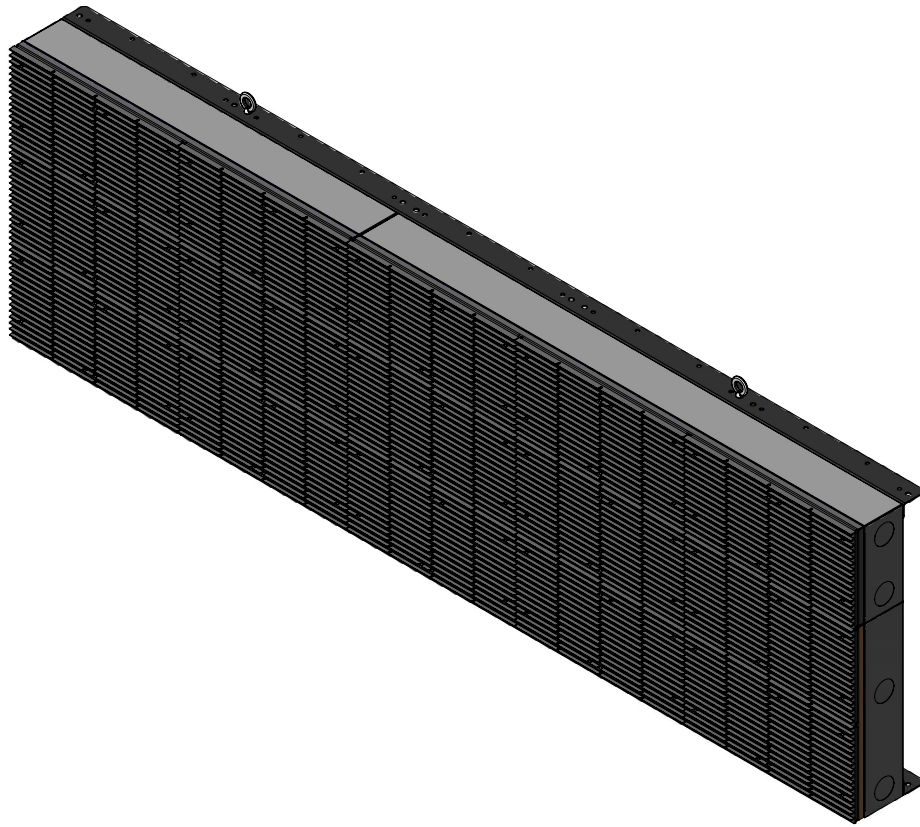

Alpha StreetSmart Series - 2020 Edition

Model 17X

© Copyright 2020 Adaptive Display Systems LLC. All rights reserved.

Adaptive Display Systems

7840 North 86th Street

Milwaukee, WI 53224 USA

414-357-2020

414-357-2029 (fax)

<http://www.adaptivedisplays.com>

Adaptive is a registered trademark of Adaptive Display Systems. Alpha StreetSmart is a registered trademark of Adaptive Display Systems. All other brand and product names are trademarks or registered trademarks of their respective companies.

Your sign was shipped with an IP address of **10.11.11.254**.

Adaptive recommends logging the new IP address below.

New IP Address:

1	INTRODUCTION	
<hr/>		
	Introducing the Alpha StreetSmart 17X Sign	1-1
	Purpose	1-1
	Revision history	1-1
	Safety information	1-1
	Equipment protection	1-2
2	EQUIPMENT DESCRIPTION	
<hr/>		
	Equipment description	2-1
	Modular construction	2-1
	Exterior views	2-2
	Opening a sign	2-3
	Interior views	2-5
	Label locations	2-7
3	MECHANICAL INSTALLATION	
<hr/>		
	Overview	3-1
	Sign mounting guidelines and requirements	3-2
	Sign painting or wrapping	3-2
	Ventilation requirements	3-3
	Wall mounting	3-4
	Monument mounting	3-5
	Pole mounting	3-7
	Lifting the sign	3-8
	Mounting the sign to the super-structure	3-9
4	ELECTRICAL INSTALLATION	
<hr/>		
	Requirements for electrical installation	4-1
	Earth-grounding signs.....	4-2
	Lightning strike protection	4-2
	Install power to the sign	4-3
5	NETWORKING	
<hr/>		
	Connecting primary and secondary signs	5-1
	Connect to the messaging computer	5-2
6	TEMPERATURE/LIGHT SENSOR INSTALLATION	
<hr/>		
	Temperature and light sensor installation	6-1
A	APPENDIX	
<hr/>		
	Technical specifications	A-1

THIS PAGE INTENTIONALLY BLANK

■ Introducing the Alpha StreetSmart 17X Sign

The 2020 Edition Alpha Street Smart 17X is an updated version of our successful StreetSmart product. The 2020 edition retains key features such as:

- Edge-to-edge display design
- Outside air is not required to cool the sign.

And for the 20202 edition we've:

- Updated the components and technology to current standards for even more robust performance and reliability
- Added a new control system with a Linux operating system to enable Ethernet communication and compatibility with more players.

■ Purpose

This manual explains how to mount and electrically connect a Alpha StreetSmart 17X Sign Installation Manual sign and is intended for sign installers.

■ Revision history

Revision	Date	Notes
1177600101 Rev A	October 27, 2020	First release.

■ Safety information

Equipment symbols



Chassis ground



Main power (I = ON, 0 = OFF)

Dangers, warnings, cautions, and notices

Dangers, warnings, cautions, and notices are posted in appropriate locations throughout this manual.

■ Equipment protection

Preventing electrostatic discharge (ESD)

This equipment contains components that may be damaged by “static electricity”, or electrostatic discharge. To prevent this from happening, be sure to follow the guidelines in Adaptive Display System’s Tech Memo 00-0005, “*Preventing Electrostatic Discharge (ESD) Damage*,” available on our Web site at <http://www.Adaptivedisplays.com>.

EMI compliance

This equipment has been tested and found to comply with the limits for a Class A digital device, pursuant to Part 15 of the FCC Rules. These limits are designed to provide reasonable protection against harmful interference when the equipment is operated in a commercial environment.

This equipment generates, uses, and can radiate radio frequency energy, and if not installed and used in accordance with installation guidelines, it may cause harmful interference to radio communications. Operation of this equipment in a residential area is likely to cause harmful interference, in which case the user will be required to correct the interference at his or her own expense.

Supplier's Declaration of Conformity 47 2.1077 Compliance Information

Unique Identifier: 11778RCCXX - ALPHA SS-17(R OR A) 0RRxCCC 120v (PRI or PRIHDMI or SEC)

(where "R = red, "A" = amber. "RR = number pixels/LED mods high, "CCC" = number of pixels/LED mods long and (PRI or PRIHDMI or SEC) = type of controller. "XX" is sequential.

Party issuing Supplier's Declaration of Conformity

ADAPTIVE Micro Systems LLC

7830 N 86th Street

Milwaukee, WI 53224

USA

<http://www.adaptivedisplays.com/>

Responsible Party - U.S. Contact Information

ADAPTIVE Micro Systems LLC

7830 N 86th Street

Milwaukee, WI 53224

USA

<http://www.adaptivedisplays.com/>

FCC Compliance Statement (for products subject to Part 15)

This device complies with Part 15 of the FCC Rules. Operation is subject to the following two conditions: (1) This device may not cause harmful interference, and (2) this device must accept any interference received, including interference that may cause undesired operation.

Thomas Mandler

Adaptive's FCC Compliance Officer 9/25/2020

Memory backup

In the event of power loss, a super capacitor in a StreetSmart sign provides power to the memory on the controller in order to save messages and time settings.

■ Equipment description

Sign models

There are two models of StreetSmart signs:

- 17A 17mm pitch amber display
- 17R 17mm pitch red display

■ Modular construction

StreetSmart signs are built using modular construction. That is, a sign may be built from smaller sections or modules as shown below. To review the technical specifications for the various sign configurations, see Technical Specifications in Appendix A.

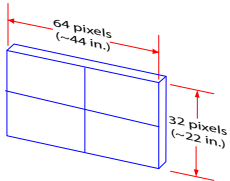
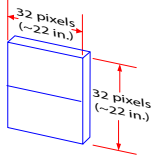
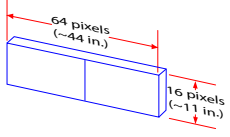
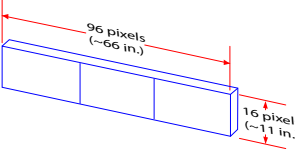
Sign Section Type	Alpha StreetSmart 17X Sign Sections (Pitch = 17.5mm / LED colors = Red or Amber)
1	
2	
3	
4	

Exterior views

Rear view

All sizes are similar.

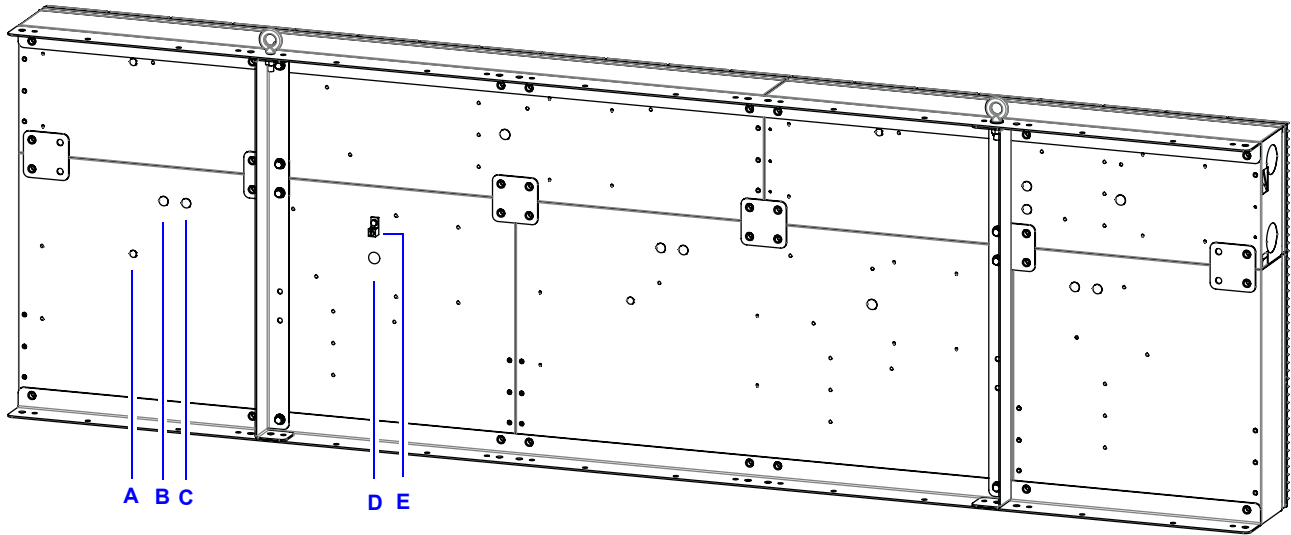

Item	Name	Description
A	LIGHT SENSOR CONNECTION (OPTIONAL)	For use with Adaptive supplied light sensor assembly. Connection is a push then twist to lock and make watertight.
B	RS485 KNOCKOUT ENTRY	Option RS485 communication entry. It is the end user's responsibility to provide the watertight conduit fitting and cabling to the sign for the RS485 cable. <ul style="list-style-type: none"> DO NOT run RS485 with AC power. It must be in a separate conduit.
C	COMMUNICATION ETHERNET EXTERNAL WATERTIGHT FITTING	Adaptive recommends using this external connection to access the ethernet communication to the sign. <ul style="list-style-type: none"> When using this connection, an outdoor rated Ethernet cable is required. Do not run Ethernet cable in same conduit as power. PoE power is present on connection for use with Adaptive supplied Wi-Fi radios.
D	AC POWER CONDUIT KNOCKOUT	The location of the power knockout hole varies with the size of the sign. <ul style="list-style-type: none"> It is the end users responsibility to provide the watertight conduit fitting and cabling to the sign.
E	EARTH GROUND LUG	It is the end user's responsibility to make this connection to the sign in accordance to the National Electrical Code (NEC) Article 250 and Local Codes. This connection is mandatory to ensure compliance with Adaptive warranty.

*Communication cabling and Power Cabling shall not be run in the same conduit.

*Conduit entry holes are 1/2-inch Trade size (7/8-inch actual diameter).

■ Opening a sign

DANGER

Hazardous voltage. Contact with high voltage will cause death or serious injury. The power switches on the circuit breaker DO NOT turn off power to all lines in a sign. Remove power at the source.

Notice: Open sign doors slowly to prevent damage to internal components.

While opening a cube door on a StreetSmart sign is a straightforward procedure, locating where a cube door starts and ends can be a challenge. This is because a StreetSmart can be made up of a number of different-sized cubes (see “Modular construction” on page 2-1).

1. Remove power from the sign at the source.
2. Locate the cube door.

Option 1: Examine the back of a sign.

The most efficient way to locate each cube door is to look at the back of a sign, as in the following example.

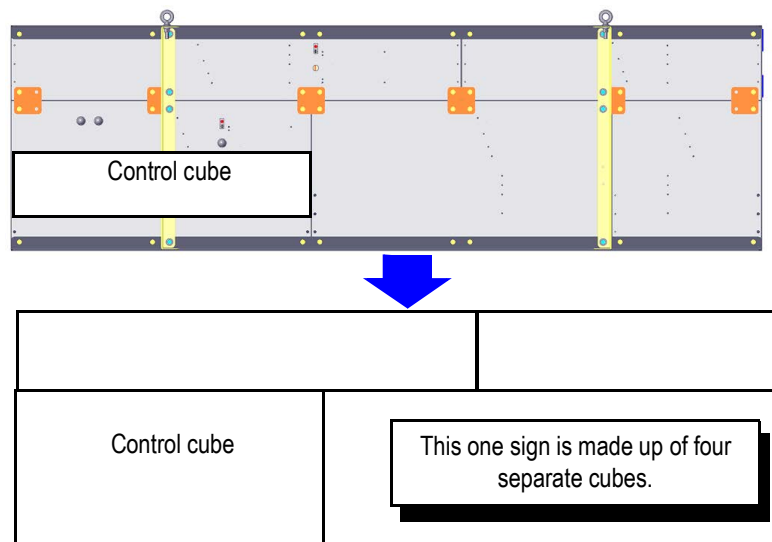



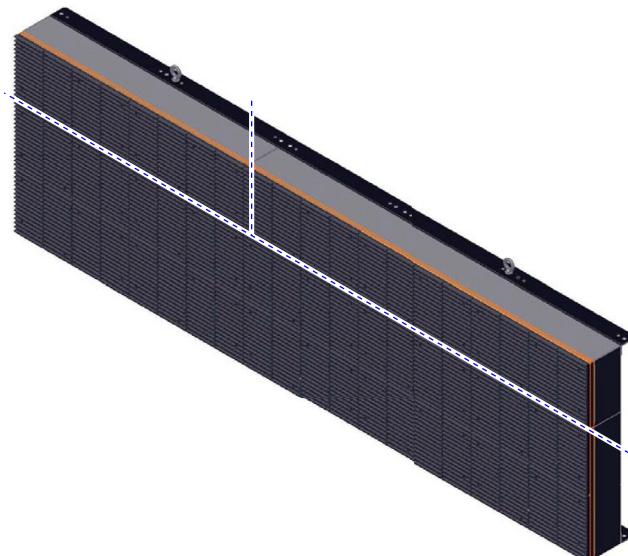

Option 2: Examine the sides of the sign.

If it is not possible to look at the back of a sign, then examine each side of the sign for clues to where each cube starts and ends.

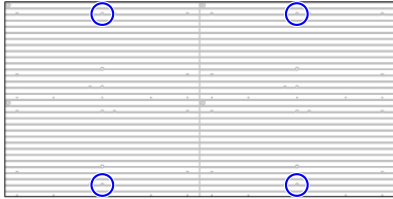

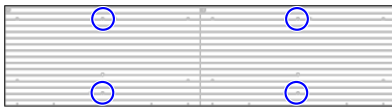
3. Locate the screws holding the door in place. Use the table below to locate the door locks.

Door size	StreetSmart 17X
2 x 2	
2 x 1	
1 x 2	
1 x 3	

4. Use a 5/32-inch hex tool to open the door locks:

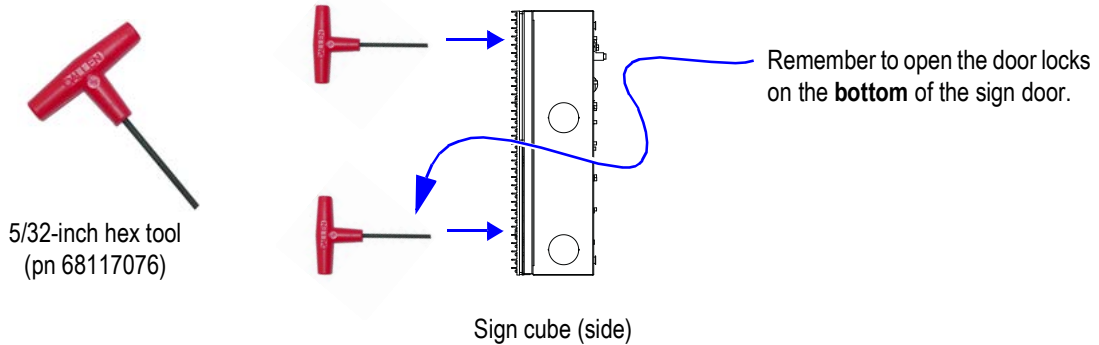

5. Carefully open the sign door:

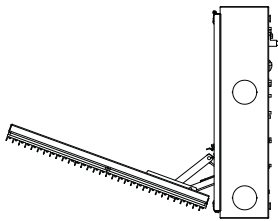

Interior views

Front view

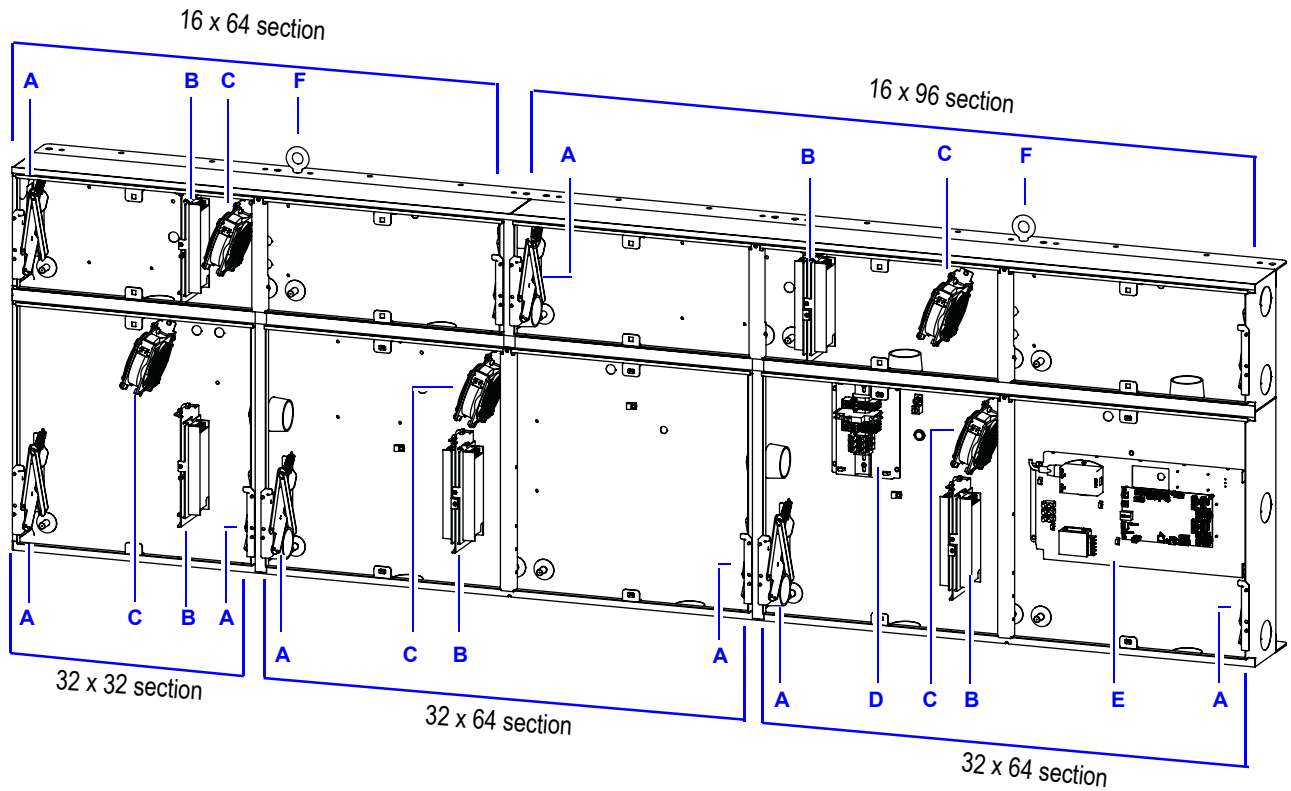

Item	Name	Description
A	SIGN DOOR HINGE	Hinge for door.
B	POWER SUPPLY	Provides DC power to sign components: <ul style="list-style-type: none"> For Adaptive 17X signs, power supplies provide 3.3 VDC.
C	FAN	<ul style="list-style-type: none"> 120V, 110 CFM
D	POWER PLATE	Incoming AC power connects to breakers and is passed through the rest of the sign. A fan test switch momentarily connects power to all the fans.
E	CONTROLLER PLATE	Contains the controller board. The controller will contain <i>one</i> of the following connectivity options: <ul style="list-style-type: none"> Ethernet (with built in PoE for Adaptive supplied Wi-Fi Radios) Wi-Fi radio Ethernet to fiber converter RS485 direct connection
F	LIFTING HOOKS	Used to lift the individual sign sections into place. These hooks should not be used to mount or hang the sign. Lifting hooks should be removed after the sign is mounted.

Door assemblies

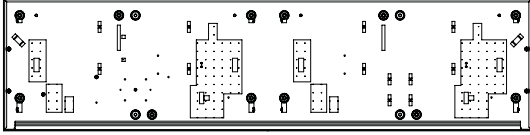

1 x 2 Door Assembly

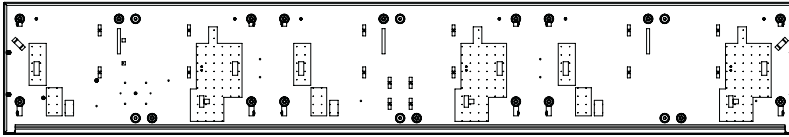

1 x 3 Door Assembly

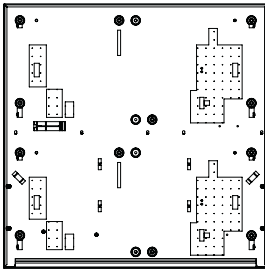

2 x 1 Door Assembly

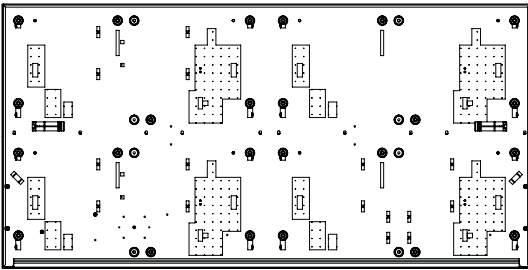

2 x 2 Door Assembly

■ Label locations

Sign rating label



SIGN MODEL#: ALPHA SS-17A 080RX160C 120 PRIHDMI _____ A



S/N: LY00002009 _____ B



SERIES: A _____ C

VOLTS: 120V _____ D

FREQUENCY: 50/60 Hz _____ D

AMPS: 0A



Sign labels are located on three places on the sign:

- On the front lower left, attached to the inlet ventilation louver
- On the back of the sign near the communications port
- On the inside of the display near the controller

Item	Name	Description
A	SIGN MODEL NUMBER	<p>SS -17A 016RX064C 120 PRI SER X</p> <ul style="list-style-type: none"> Only appears after initial release X = B, C, D, etc PRI = Primary sign SEC = Secondary sign PRIHDMI = Multiple primary unit used with secondary unit Sign input voltage Number of rows and columns in pixels LED color: <ul style="list-style-type: none"> • R = Red • A = Amber Model: 17 = 17.5mm pitch StreetSmart sign
B	SERIAL NUMBER	Consecutive, unique identification number for the sign.
C	SERIES LETTER	Revision level of sign.
D	ELECTRICAL INFORMATION	Input voltage, frequency, and total amperage of the sign: "AMPS" = total sign amperage. "CIRCUIT A", "CIRCUIT B", and so on = a sign that needs multiple, separate circuits and the required amperage for each circuit.

THIS PAGE INTENTIONALLY BLANK

■ Overview

The Alpha StreetSmart signs use a modular design allowing for several different sign sizes and configurations.

The sign must be installed onto a super-structure designed to withstand live loads and comply with all national and local codes. Live loads include loading from wind and seismic events. Because every sign installation is unique, there is no single procedure for mounting.

WARNING

Sign must be supported (affixed to a super-structure able to withstand live loads and comply with all national and local codes) prior to servicing, otherwise the sign may tip, causing serious injury.

Structures defined

Sub-structure: The formed steel angle on the back of each sign section (top and bottom). Supplied with the sign.

Super-structure: Customer or installer supplied structure to which the sign is mounted. Super-structures must be approved by a qualified structural engineer.

ID sign: Company name and/or logo sign supplied by the customer or installer. ID signs used in conjunction with Adaptive signs must not interfere with Adaptive's ventilation, electrical, and mounting requirements.

Super-structure design

The design of a sign's support structure depends on a number of factors: mounting methods, building codes, foundation, sign size, sign weight, sign height, wind loading, and seismic loading.

■ Sign mounting guidelines and requirements

Notice: Do not use the sign's ground-lug for grounding installation equipment such as welding equipment or the warranty will be void. Only the sign sub-structure may be welded. Welding any other part of the sign will void the warranty.

The method used to mount signs varies greatly from location to location. The installer must ensure the installation complies with all national and local codes.

A qualified structural engineer must review the structure and attachment points to the super-structure. The back of the sign uses 2" x 3" x 0.13" formed steel angle. These angles assist in mounting the sign.

Sign installers must comply with the following Adaptive requirements or the sign warranty will be void:

- Any ID sign, fascia trim, or structure used above the sign must either have flashing or extend past the face of the sign.
- **DO NOT** allow water to pool / gather underneath or on top of the sign.
- **DO NOT** allow water from an above ID sign, fascia trim, flashing, or any other structure to drip directly onto the sign's door seams.
- **DO NOT** seal the sign in any way that restricts hot air from escaping the inside of the sign.
- Comply with all sign ventilation and clearance requirements. Refer to "Ventilation requirements" on page 3-3.

■ Sign painting or wrapping

Notice: Painting or vinyl wrapping the top and/or the back of the sign will void the warranty.

The sides and bottom of the sign may be painted or vinyl wrapped without affecting the product warranty. When painting the sign, follow the paint manufacturer's instructions for surface preparation of mill finish aluminum.

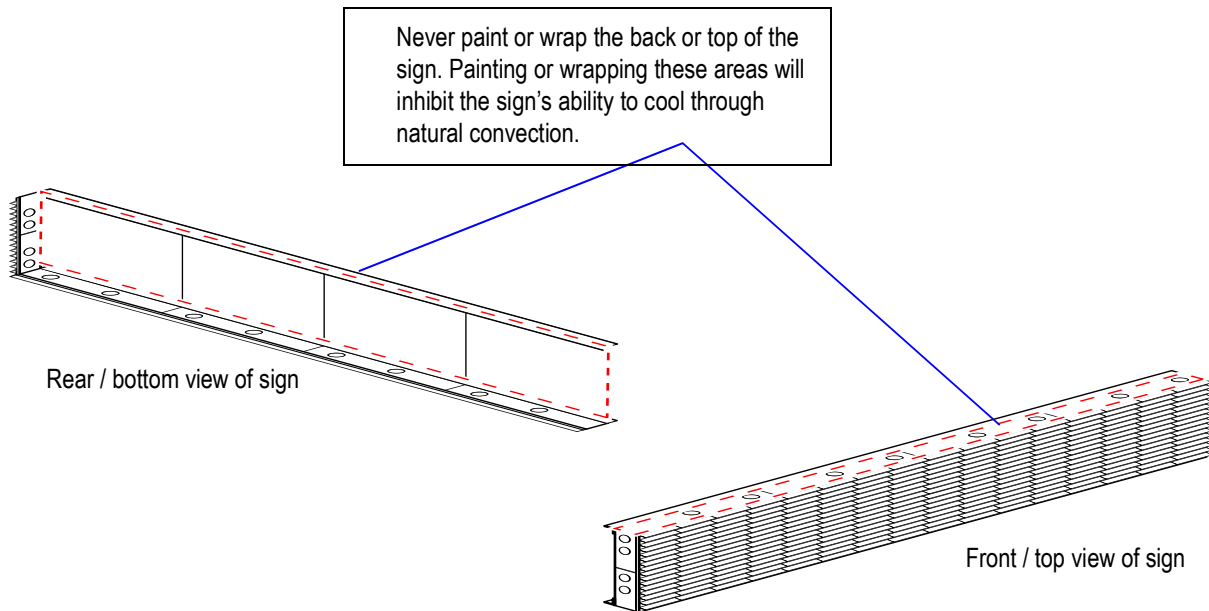

■ Ventilation requirements

Notice: Inadequate ventilation will ultimately result in component failure that may not be covered under warranty.

Signs require obstruction-free space for adequate air ventilation between solid mounting surfaces and the top, bottom, and sides of the sign. This is required for all wall, monument, and pole mounted signs. Refer to “Wall mounting” on page 3-4, “Monument mounting” on page 3-5 and “Pole mounting” on page 3-7 for more details.

Always take into consideration other neighboring heat sources such as back-lit signs, lighting sources, etc. and add additional ventilation when needed.

Note: Shading the back of the sign will enhance thermal performance.

Adaptive Explains

How does the sign cool itself?

Although the sign cases are completely enclosed with no forced air ventilation, the sign does rely on natural convection to cool. The top and back of the sign case uses these surfaces as heat sinks to cool the inside cabinet temperatures. An internal mixing fan helps cooling by mixing the air inside bringing it all to a more uniform temperature or isothermal.

The sign is enclosed to keep out contaminants which adversely affects the sign from corrosion and dirt build-up. The dirt build-up or corrosion deters the sign's ability to cool.

What is natural convection?

Natural convection is a type of heat transportation. In natural convection, air surrounding a heat source receives heat, becomes less dense and rises. The surrounding, cooler air then moves to replace it. This cooler air is then heated and the process continues, forming a convection current.

For every installation, provide adequate ventilation or the sign warranty may be void:

- **DO NOT** mount air ducts (vents) directly to the sign or sign's sub-structure.
- **DO NOT** modify the sign or sign's sub-structure for ventilation purposes. The super-structure design **MUST** incorporate adequate ventilation.
- Provide 7 square inches of ventilation for every 1-square foot of sign. For signs under 7 feet in height, use 3.5 square inches for every 1 square foot of sign. Ventilation is defined as obstruction-free space.
- Ventilation air ducts **MUST** be installed evenly spaced around the perimeter of the sign (top, bottom, and sides). Evenly spaced air ducts help maintain a consistent air flow around the sign.
- Air duct size **MUST** be a minimum of 7 square inches (equivalent to a 3 inch round air duct).
- If the sides of the sign are covered (enclosed), install a minimum of two air ducts in each side covering.
- Provide a minimum clearance of 1 inch above and below the sign.
- Provide a minimum clearance of 6 inches behind the sign.

Wall mounting

Signs require obstruction-free space for adequate air ventilation between solid mounting surfaces and the top, bottom, and sides of the sign.

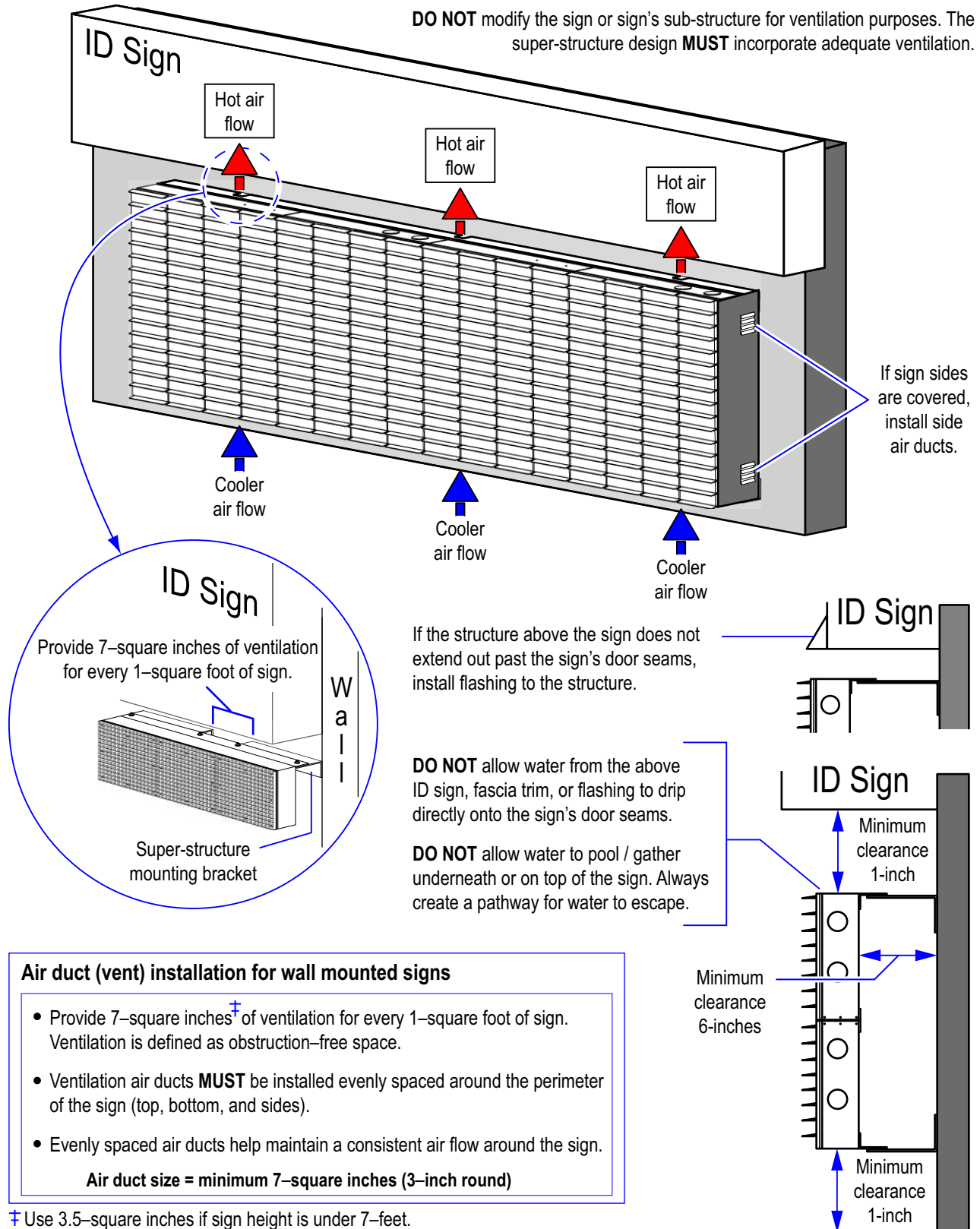

Monument mounting

If there is an obstruction on the outside of the sign (as in a monument-style installation), care must be taken to assure the sign is able to cool. Air ducts **must** be used in the monument to allow air to flow behind the sign. When monument mounting a Adaptive Displays sign, use air ducts to help hot air escape. Adaptive recommends the installation of fans to force hot air out of the air ducts.

Recommended method

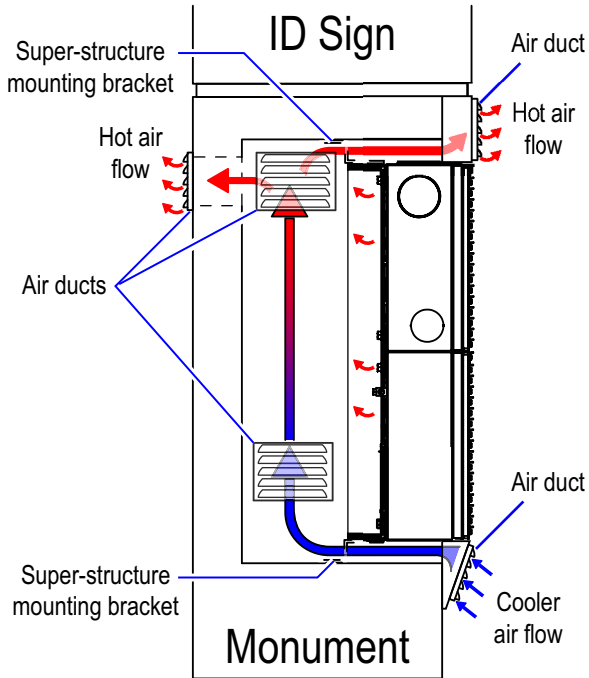

Alternative method

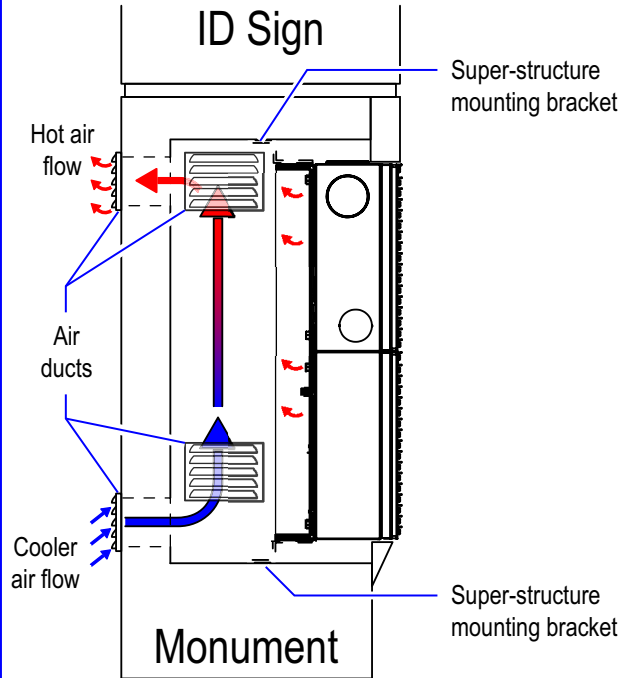

Clearance requirements

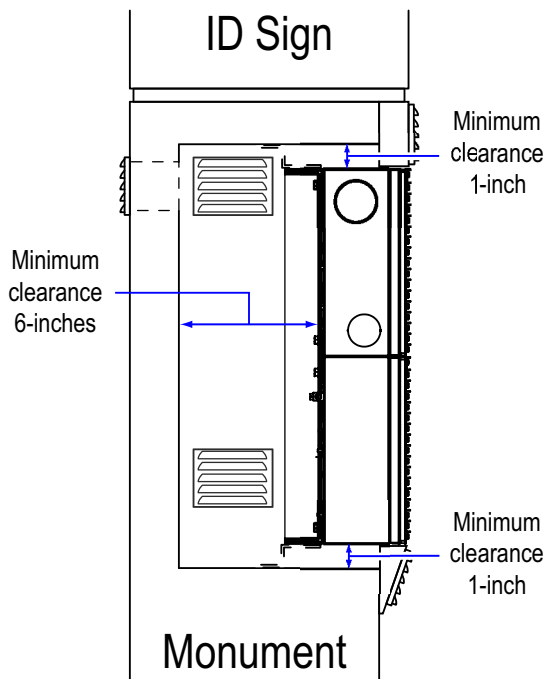

Follow these guidelines or sign warranty will be void:

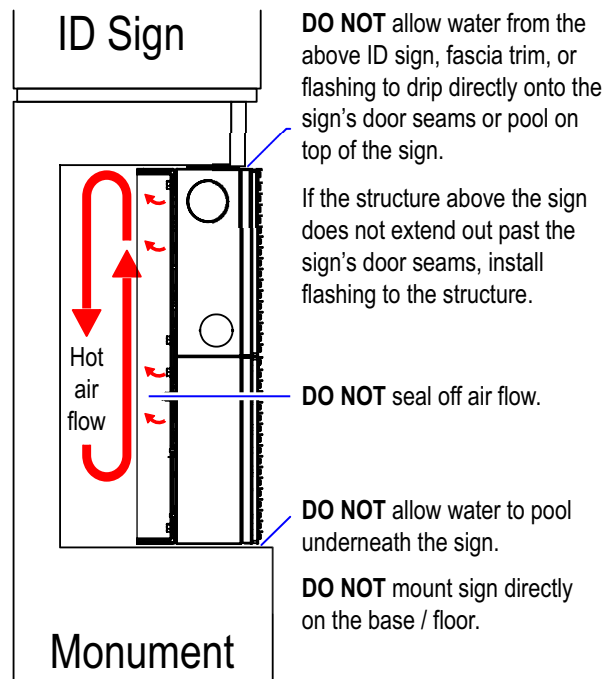

■ Pole mounting

Signs require obstruction-free space for adequate air ventilation between solid mounting surfaces and the top, bottom, and sides of the sign.

Air duct (vent) installation for pole mounted signs

- Provide 7–square inches[‡] of ventilation for every 1–square foot of sign. Ventilation is defined as obstruction–free space.
- Ventilation air ducts **MUST** be installed evenly spaced around the perimeter of the sign (top, bottom, and sides).
- Evenly spaced air ducts help maintain a consistent air flow around the sign.

Air duct size = minimum 7–square inches (3–inch round)

[‡] Use 3.5–square inches if sign height is under 7–feet.

DO NOT wrap or paint sign top (super-structure must allow hot air to escape).

DO NOT allow water to pool / gather underneath or on top of the sign. Always create a pathway for water to escape.

DO NOT modify the sign or sign's sub-structure for ventilation purposes.

If the structure above the sign does not extend out past the sign's door seams, install flashing to the structure.

Provide a minimum clearance of 1–inch above and below the sign and 6–inches behind the sign.

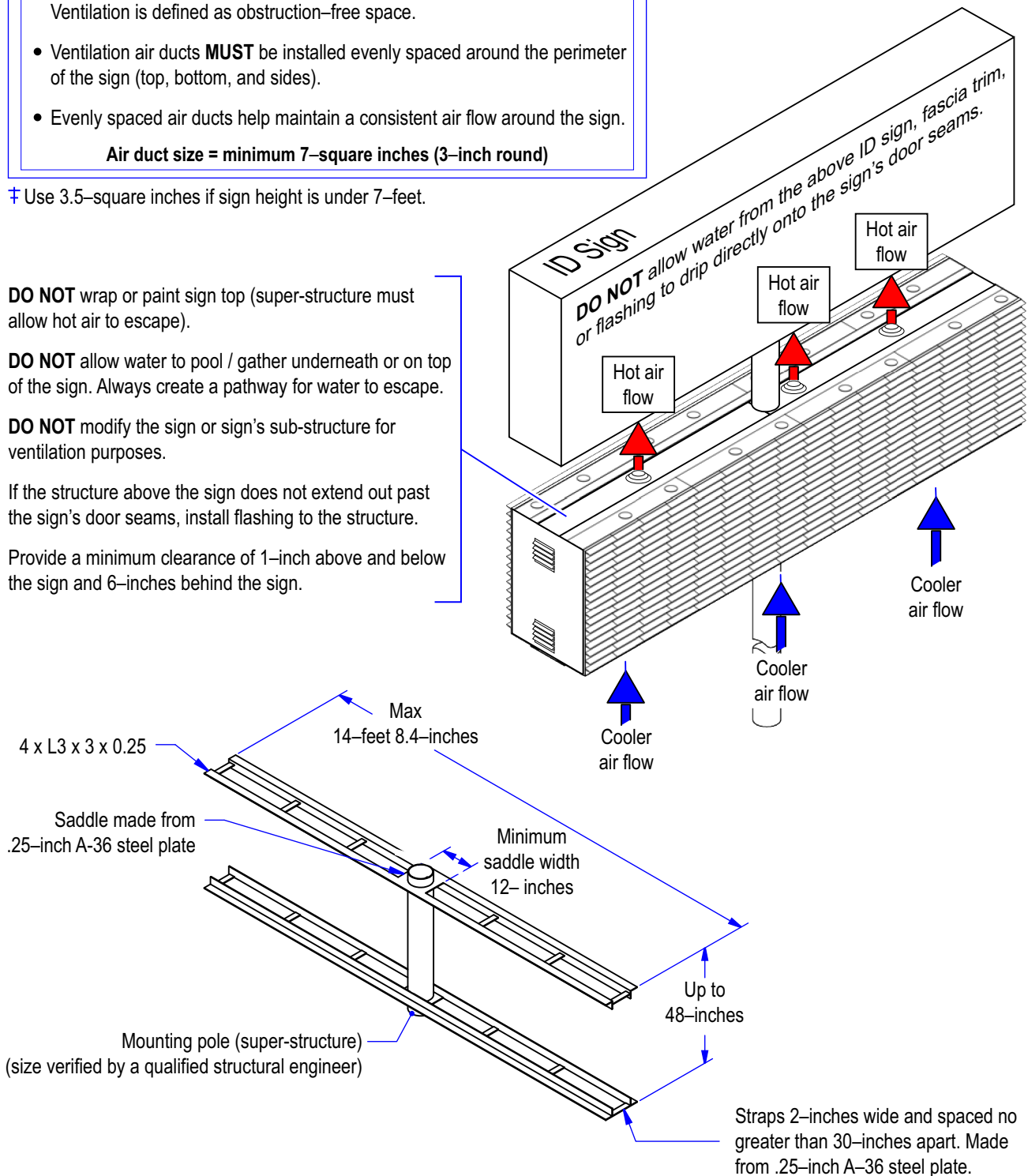

■ Lifting the sign

WARNING

Crush hazard. Improperly lifting of a sign can create a crush hazard causing personal injury and damage to the sign. Do not use eyebolts to lift an assembled sign. They are designed to only lift a sign section from the shipping container. Lift the sign evenly and level, with no more than a 15 degree tilt.

1. Use a lifting bar adjusted to the width of the lifting hardware on the sign to raise the shippable section. After mounting the sections, remove the lifting hardware or corrosion to the sign may occur. Failure to follow these instructions will void the warranty.

15° Maximum lifting tilt

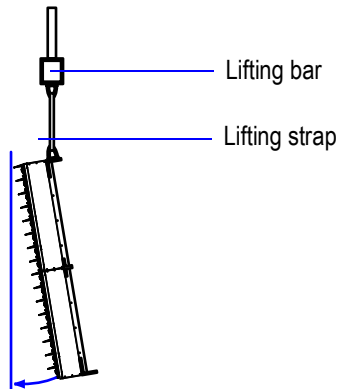

15° Maximum tilt

PREFERRED METHOD

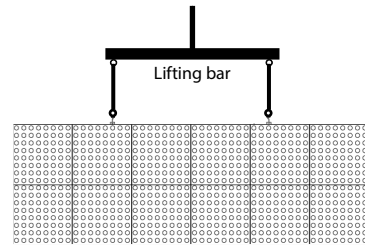

ALTERNATE METHOD

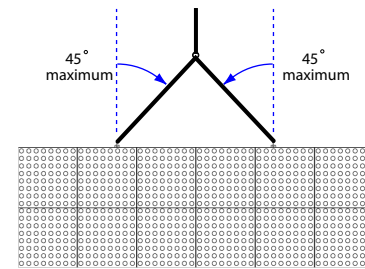

2. Position and secure the sign on the super-structure.

Note: Eye bolts can be removed after sign is mounted.

■ Mounting the sign to the super-structure

The methods used to mount a sign to a super-structure vary greatly. It is the installer's responsibility to ensure that the installation complies with all national and local codes.

Notice: Drill holes as needed in the sign's sub-structure for fasteners. Only drill holes into the sign when field upgrade instructions or Adaptive Displays' Technical Service Department explicitly states to do so. Drilling holes in the sign under any other circumstance will void the sign's warranty.

When drilling holes or welding the sign's sub-structure, follow these guidelines or the warranty will be void:

- **DO NOT** drill additional conduit holes through the controller plate in the control case.
- **DO NOT** drill additional conduit holes along the bottom of the case, because water may pool there.
- **DO NOT** use the sign's ground-lugs for grounding installation equipment such as welding equipment.
- **DO NOT** weld any part of the sign except for the sign's sub-structure.

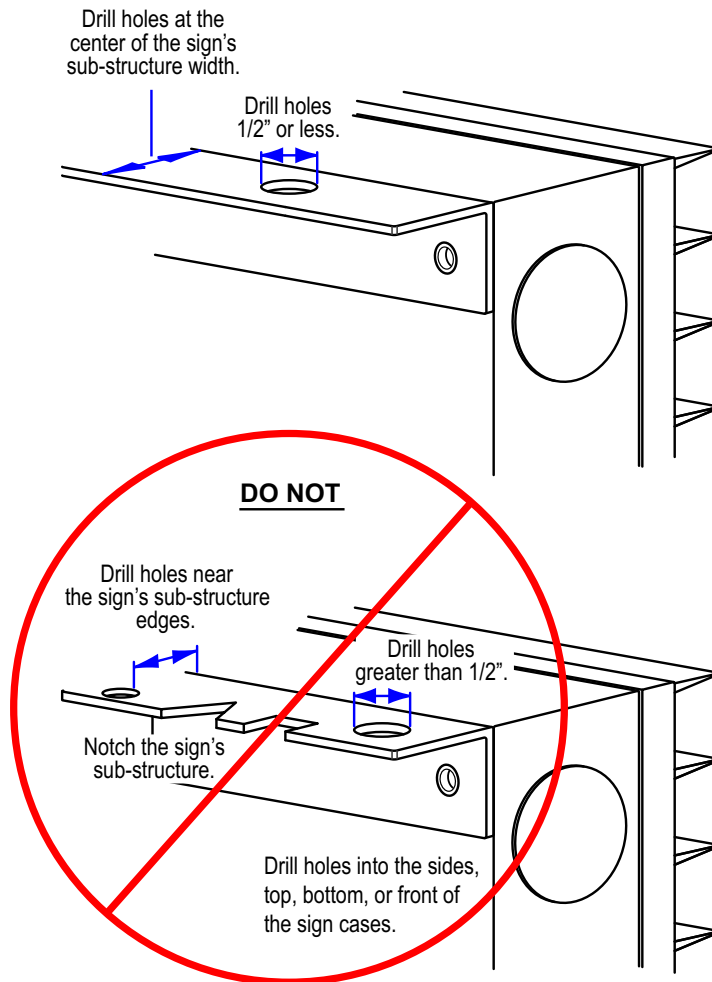

Notice: Dissimilar metals must be isolated to avoid galvanic corrosion.

Any area on the sign's frame from which paint is removed during mounting, must be recoated with paint that is UL recognized to standard UL-1332, category DTOV2. Failure to repaint the area will result in accelerated corrosion of the sign's structure. Adaptive Displays is not responsible for any failure in the sign's structure because of accelerated corrosion. Failure to comply will void the sign's warranty.

THIS PAGE INTENTIONALLY BLANK

■ Requirements for electrical installation

DANGER

Hazardous voltage. Contact with high voltage will cause death or serious injury. The power switches on the circuit breaker DO NOT turn off power to all lines in a sign. Remove power at the source.

Notice: The following electrical installation requirements must be followed or the sign warranty will be voided. Electrical installation must only be attempted by a qualified electrician. Electrical connection must comply with all applicable national and local codes.

The electrical installation of signs varies greatly. The following bullet points are requirements. **It is the installer's responsibility to ensure that the installation complies with all national and local codes.**

- All power wiring **must** be from circuit breaker-protected lines.
- **DO NOT** connect the sign to a GFI-protected circuit.
- A disconnect device must be installed in the building wiring for the branch circuit(s) supplying the sign. For the power requirements for each sign, refer to the sign rating label located on front, back and interior of the sign.
- The sign **must** be properly grounded according to the applicable national and local electrical codes (for example, NEC Article 250 and 600, and IEEE 1100-1999).
- All electrical conduit connections **must** be watertight.
- Torque terminals to a minimum of 13 in/lbs (1.5 N/m) and a maximum of 16 in/lbs (1.8 N/m).
- Use minimum 80° C copper wire only.
- **DO NOT** drill additional conduit holes in the sign.
- **DO NOT** route power and communication wires out of the cube door and around the side of the sign; the wires will be damaged when the door is closed.
- Separate conduits **must** be used for signal wires (for example, Ethernet, RS485) and for power wires. However, fiber optic wire may be run in the same conduit with power wires.

Power requirements

Adequate power must be run to the sign in accordance with the "Technical Specifications" on page A-1.

- Standard configuration is 120VAC. The sign may be configured as 240VAC as a custom order.
- The sign **must** be run on its own dedicated circuit to ensure proper operation. This is particularly important when the sign is installed in a structure containing ballasts for fluorescent lamps. They **must** have their own circuit. Not complying with this requirement can lead to intermittent sign operation or malfunction.
 - **Do NOT** run power to the sign and the ballasts off the same circuit.
 - When ballasts are used in the same vicinity of the Adaptive sign, it is recommended that they be of the electronic low harmonic type to further reduce the risk of any interference with the sign.
 - Wire gauge and breakers must be sized or verified in accordance with Adaptive's input power specifications, the National Electric Code, and applicable local codes. **Under-sizing the wire gauge or breaker size can lead to intermittent sign operation or malfunction.**

Adaptive Explains

Is it necessary to run two conduits to a sign?

It is *not* always necessary. Two conduits are only necessary when communication wire, like CAT-5 wire, is run to a sign from a computer or from another sign. In these cases, one conduit would contain the sign's power wires and the other conduit the communication wires.

If power and communication wires are put in the same conduit, there is a chance the communication wires might pick up electrical interference from the power wires. For example, when a live power cord is placed next to a stereo speaker wire, the interference from this cord may cause the speaker to hum. In the case of a sign, this same effect could disrupt messages sent to the display.

On the other hand, *fiber optic cable* and power wires can share the same conduit because fiber optic cable is immune to electrical interference.

■ Earth-grounding signs

Properly grounding each sign is necessary because it is an essential means of preventing shock, shock hazards, and potential fire hazards.

WARNING

Failure to properly ground the sign could result in elevated voltage from lightning entering the sign seeking a path to earth. The high voltage can result in electric shock, fires, and the destruction of the sign from lightning.

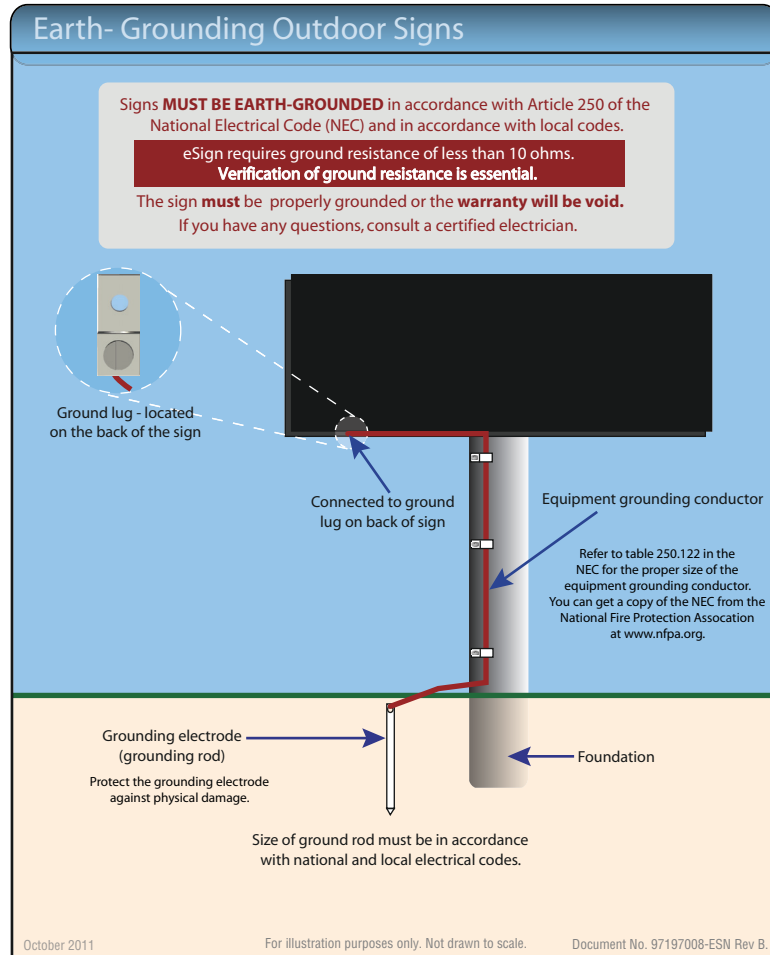

The following guidelines must be followed or the warranty will be void:

- Signs **must** be grounded in accordance with Article 250 of the National Electrical Code and in accordance with applicable local codes.
- **Do NOT** terminate the ground on metal poles or buildings. The metal will corrode, resulting in deteriorated grounding properties. Additionally, metal poles or buildings are often mounted on material that does not provide an effective ground.

Adaptive also recommends the following guidelines:

- Use copper-clad ground rods as the grounding electrode. They provide effective grounding for an indefinite period of time.
- Depending on the local soil conditions and codes, more than one ground rod may need to be installed.
- Since moisture becomes more stable at greater distances below the earth's surface, when possible, install the ground rod so that eight feet extend below the frost line to lessen the deviation in the system's resistance.
- Verify the grounding electrode conductor is securely attached at both ends.

■ Lightning strike protection

A sign bonded to an earth ground has a means of dissipating the high voltage and current from a lightning strike. The resistance of the grounding electrode must be as low as possible. However, damage can still occur to a sign's electronic equipment from lightning voltage transients.

Though some surge protection is incorporated into a sign, to protect a sign from high-voltage lightning transients, surge protectors need to be installed in accordance with NEC Articles 280 and 285 and local codes.

■ Install power to the sign

1. When facing the sign, the power connections are located in the bottom right hand corner of the sign. This door must be opened to access the power panel. See "Opening a sign" on page 2-3.
2. Run power to the sign using weather-tight conduit.
3. Connect each power circuit to the appropriate wireway power terminal on the power plate.

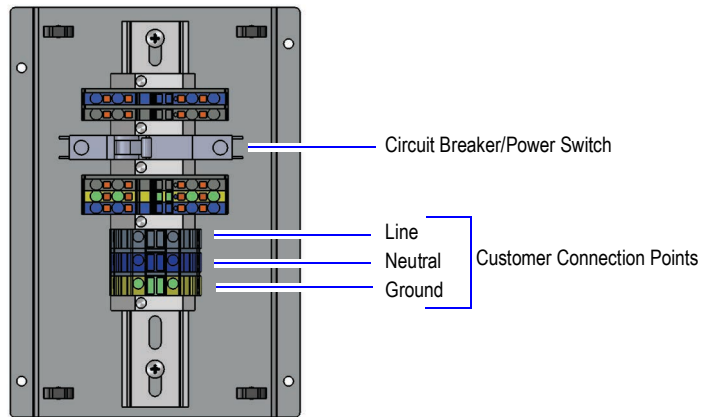

4. Connect a minimum of one grounding lug to an earth-ground rod.

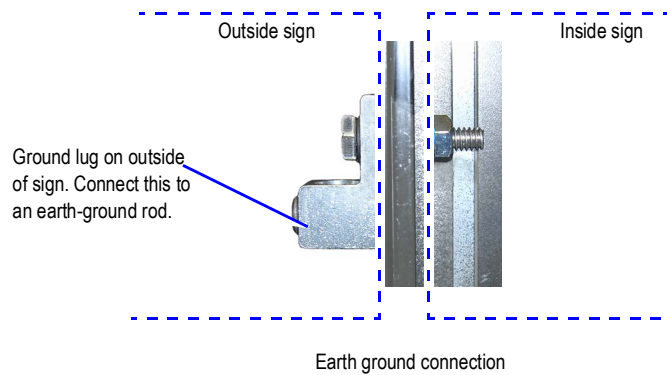

Tip: Ground lugs are located near each power entry hole on the back of the controller case, and if applicable the secondary power case.

5. Place the circuit breaker switch in the on position.
6. Close the sign doors.

THIS PAGE INTENTIONALLY BLANK

■ Connecting primary and secondary signs

When signs are connected in a primary / secondary configuration, they will display the same messages at the same time.

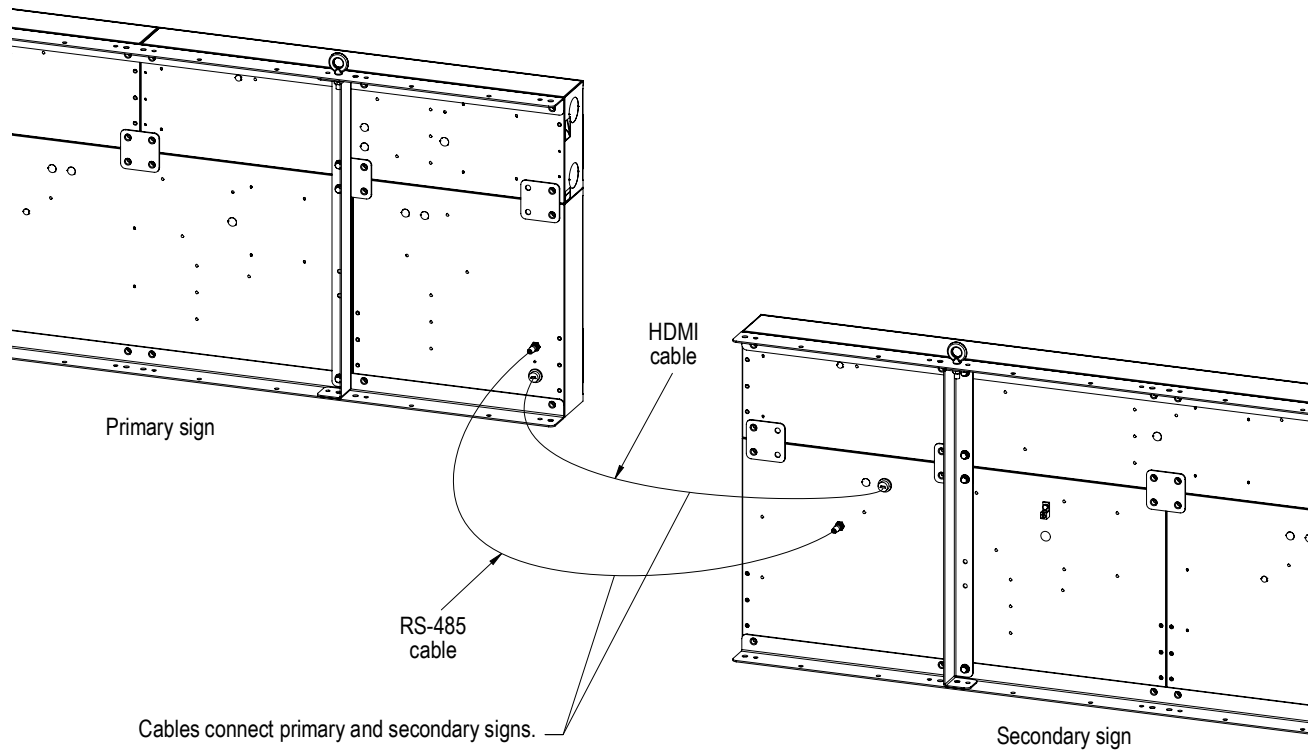

1. Plug the HDMI cable into the back of each sign. Push and twist the connector to lock and make the connection watertight.
2. Plug the RS-485 cable into the back of each sign. Push and twist the connector to lock and make the connection watertight.

■ Connect to the Messaging Computer

In order to display messages, a sign must be connected to a computer that is running AlphaNET software or other software compatible with the player installed on the controller. This computer is referred to as the messaging computer. The messaging computer is not supplied by Adaptive.

There are a number of ways to connect the messaging computer to a sign. Refer to the following pages for information about your connection option.

Connect via Ethernet

Note: Outdoor rated Ethernet cable is customer supplied.

1. Plug the cable into the connection on the back of the sign. No additional connections are required inside of the sign for communication.

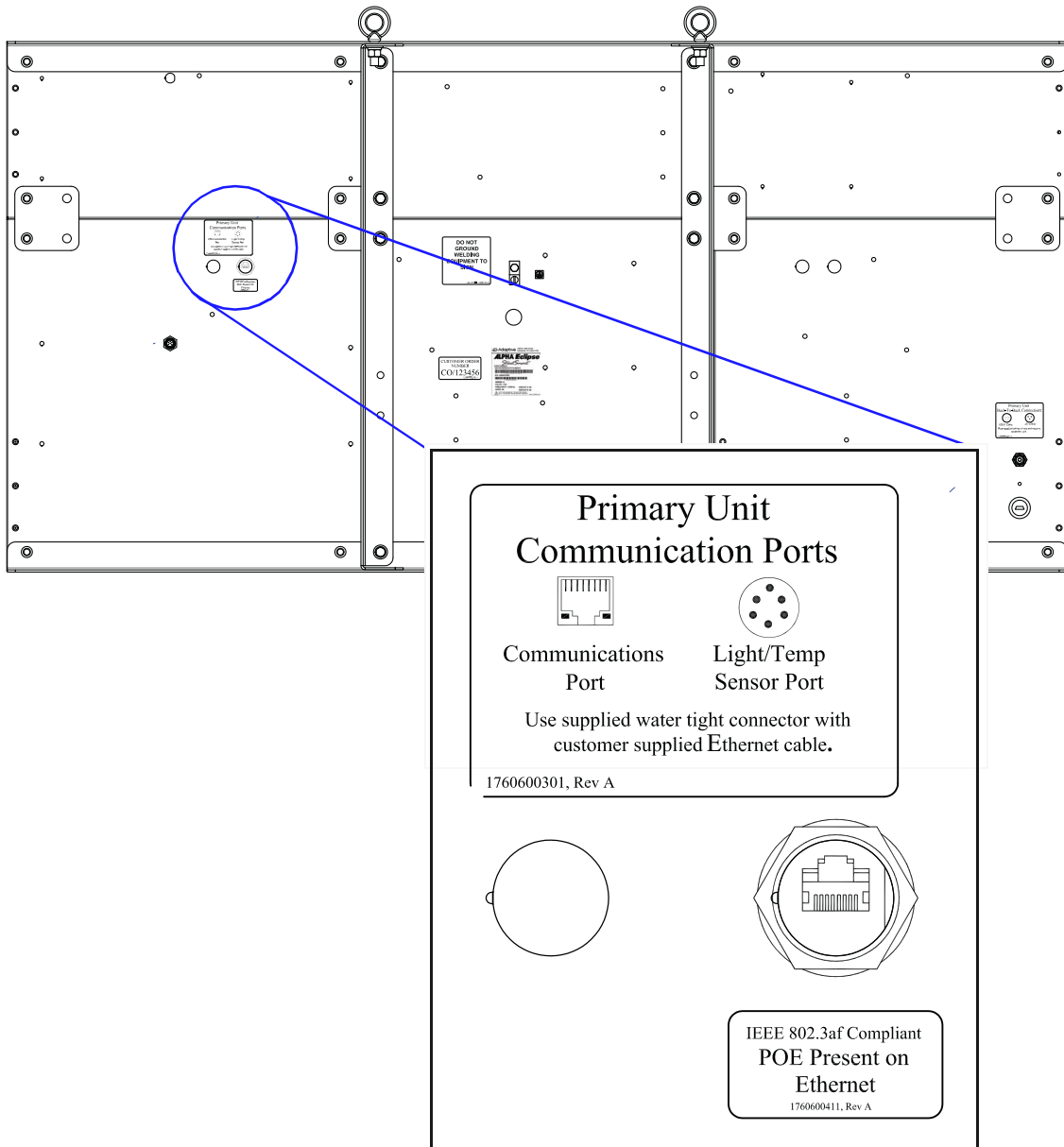

Connect via RS-485

When signs are networked together, it is necessary to properly terminate the network. This is necessary to ensure that the signs communicate with each other and messages are displayed correctly. Termination should only be applied when a sign is at the end of the RS-485 network. Signs between the ends should not have termination.

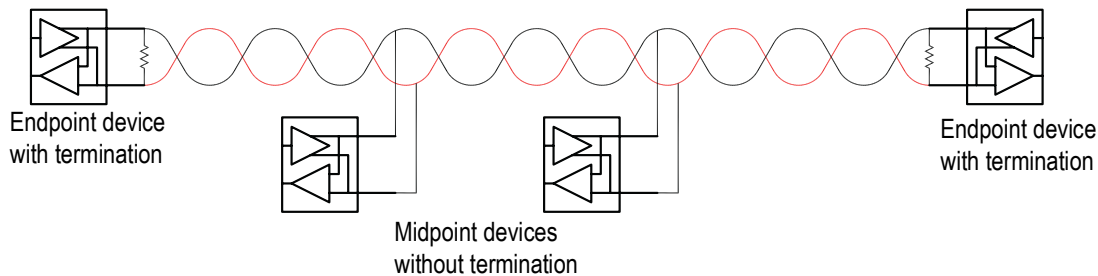

Hard termination should be used only at the devices at the end of the network. Soft termination can be used in place of hard termination in order to reduce electrical burden on the network devices but may affect the network bandwidth. Signs between the end of the network should be wired with no termination.

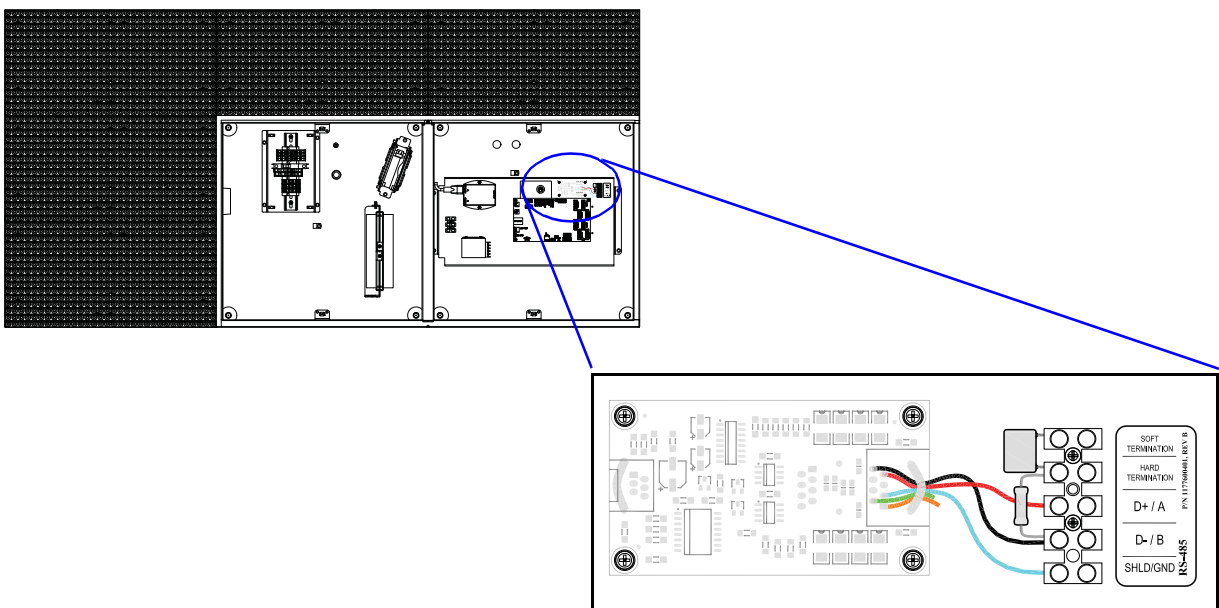
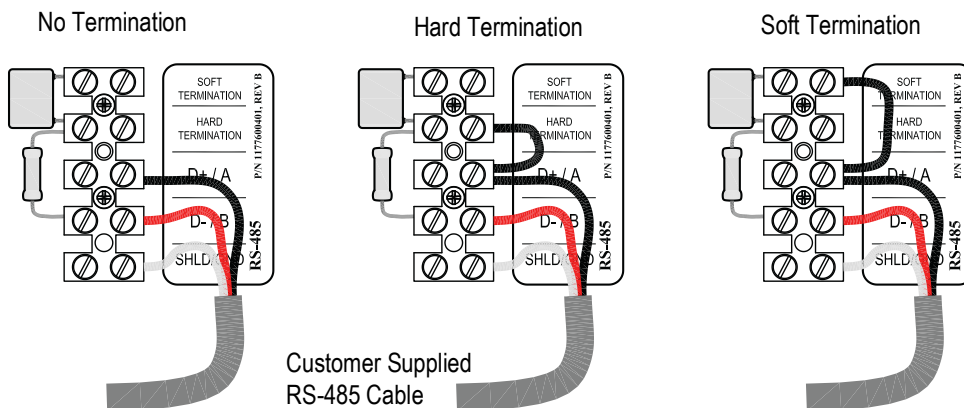

■ Temperature and light sensor

The temperature and light sensor are separate components that ship wired together and ready for installation.

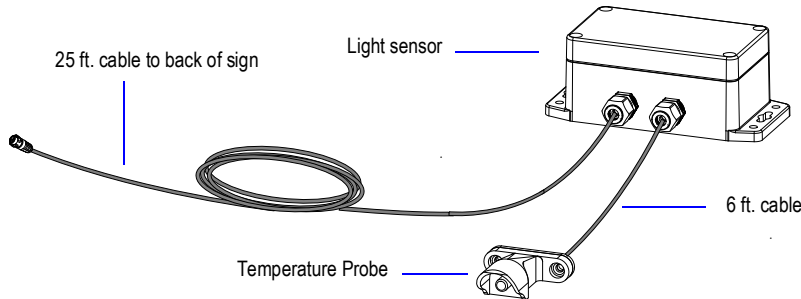

Select locations

Choose an installation location that meets the following criteria. Otherwise, the temperature and light sensors may record inaccurate temperature readings and will not correctly dim the sign.

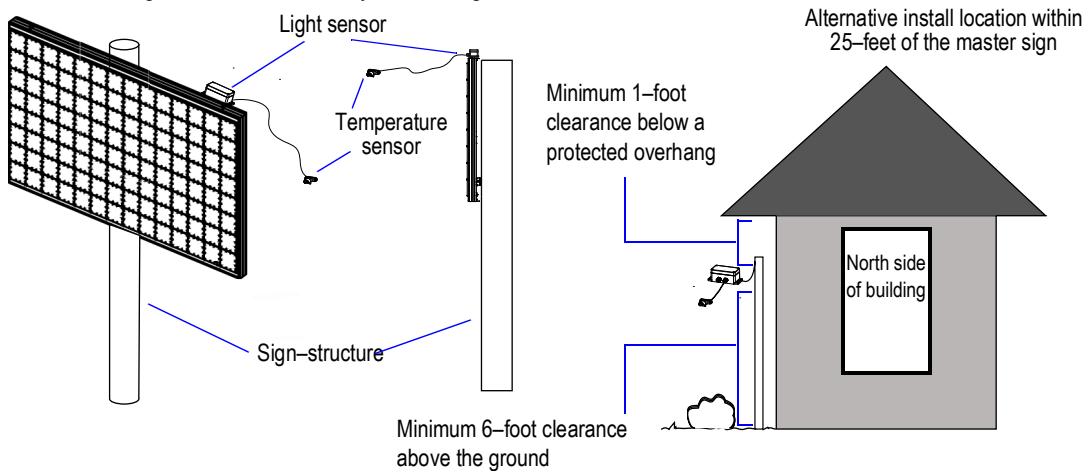

Light sensor

- When possible, mount closest to the part of the sign that is facing north.
- Mount at least six feet above the ground, and at least one foot below the eave of a protected overhang, so convection currents (rising hot air flow) are not trapped around the sensor.
- Install the sensor with the clear cover facing up.
- The long sides of the sensor should be parallel to the front and back of the sign.
- Make sure convection currents are not blocked by a mounting plate if used.

Temperature probe

- Probe should be on the north side of the sign or building, so the probe is not in direct sunlight.
- Background of the location should be a light color. Avoid locations with a dark background.
- Probe should be at least six feet off the ground, and at least one foot below the eave of a protected overhang, so convection currents (rising hot air flow) are not trapped around the sensor.
- Install the probe above vegetation. Do not install it above asphalt or blacktop.
- Ensure air circulation is not restricted by walls or other obstructions.
- Shield the sensor from heat sources, such as direct sun, reflected heat, chimneys, lamps, vents or HVAC ducts.
- Make sure convection currents are not blocked by mounting plates if used.

Connect the light sensor/temperature probe

1. Route and secure the sensor cable's pathway to the back of the primary sign.
2. Plug the sensor cable into the back of the primary sign. Push in and twist the connector to lock it into place.

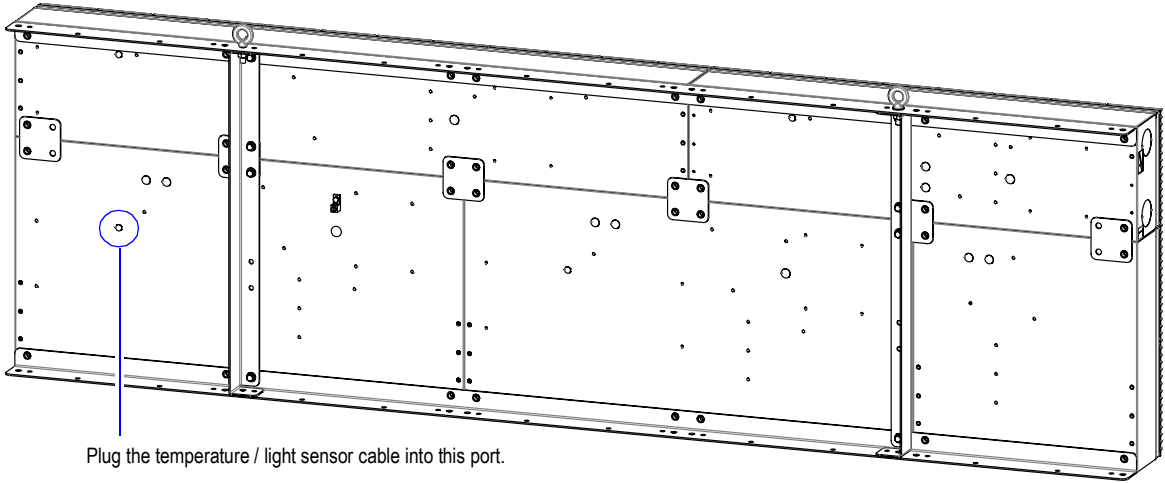

Plug the temperature / light sensor cable into this port.

■ Technical Specifications

The most current specifications are maintained on Adaptive's website (www.adaptivedisplays.com).

DANGER

Hazardous voltage. Contact with high voltage will cause death or serious injury.
The power switches on the circuit breaker DO NOT turn off power to all lines in a sign. Remove power at the source.

Notice: The following electrical installation requirements must be followed or the sign warranty will be voided.
Electrical installation must only be attempted by a qualified electrician. Electrical connection must comply with all applicable national and local codes.

Requirements for electrical installation

The electrical installation of signs varies greatly. The following bullet points are requirements. It is the installer's responsibility to ensure that the installation complies with all national and local codes.

- All power wiring must be from circuit breaker-protected lines.
- DO NOT connect the sign to a GFI-protected circuit.
- A two-pole disconnect device must be installed in the building wiring for each branch circuit supplying the sign.
- The sign must be properly grounded according to the applicable national and local electrical codes (for example, NEC Article 250 and 600, and IEEE 1100-1999).
- All electrical conduit connections must be watertight.
- Use minimum 80° C copper wire only.
- Torque terminals to a minimum of 13 in-lbs (1.5 N/m) and a maximum of 16 in-lbs (1. N/m).
- DO NOT drill additional conduit holes.
- DO NOT route power and communication wires out of the cube door and around the side of the sign; the wires will be damaged when the door is closed.
- Separate conduits must be used for signal wires (for example, Ethernet, RS485) and for power wires. However, fiber optic wire may be run in the same conduit with power wires.

Power requirements

- The sign is available in two configurations: Standard configuration is 120VAC. 240VAC is available as a custom order.
- The sign must be run on its own dedicated circuit to ensure proper operation.
- Wire gauge and breakers must be sized or verified in accordance with Adaptive's input power specifications, the National Electric Code, and applicable local codes. Under-sizing the wire gauge or breaker size can lead to intermittent sign operation or malfunction.

Specifications

Note: 17X case depth = 9.875 inches from the front of the display to the back of the steel mounting angle.

Rows	Columns	Height (Ft and In)	Width (Ft and In)	Weight (Pounds)	Number of Power Entries	Watts AC		Amps @ 120 VAC	
						Red	Amber	Red	Amber
16	64	11	3'-8"	54	1	72	111	0.7	1.0
	96		5'-6"	69		101	159	0.9	1.4
	128		7'-4"	93		145	222	1.3	1.9
	160		9'-2"	109		173	270	1.5	2.3
32	64	1'-10"	3'-8"	62	1	130	207	1.1	1.8
	96		5'-6"	92		202	317	1.7	2.7
	128		7'-4"	111		259	413	2.2	3.5
	160		9'-2"	40		332	524	2.8	4.4
48	64	2'-9"	3'-8"	100	1	202	317	1.7	2.7
	96		5'-6"	138		303	476	2.6	4.0
	128		7'-4"	173		404	635	3.4	5.3
	160		9'-2"	211		505	794	4.3	6.7
64	64	3'-8"	3'-8"	113	1	259	413	2.2	3.5
	96		5'-6"	164		404	635	3.4	5.3
	128		7'-4"	194		519	826	4.4	6.9
	160		9'-2"	246		664	1048	5.6	8.8
80	64	4'-7"	3'-8"	142	1	332	524	2.8	4.4
	96		5'-6"	202		505	794	4.3	6.7
	128		7'-4"	249		664	1048	5.6	8.8
	160		9'-2"	309		837	1318	7.0	11.0

THIS PAGE INTENTIONALLY BLANK

PART NUMBER 1177600101 REV A



Adaptive Display Systems
7840 North 86th Street
Milwaukee, WI 53224 USA
414.357.2020
www.AdaptiveDisplays.com